

Data Sheet | Item Number: 2059-321/998-403

SMD PCB terminal block; 0.5 mm²; Pin spacing 3 mm; 1-pole; PUSH WIRE®; in tape-and-reel packaging; black

<https://www.wago.com/2059-321/998-403>

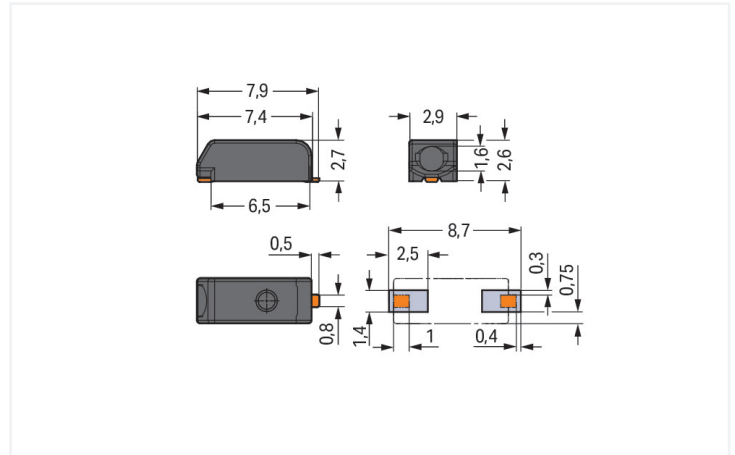

Color: ■ black

Dimensions in mm

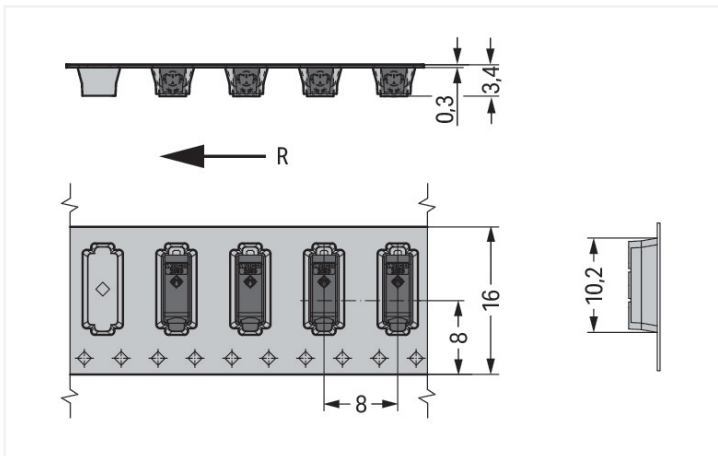

Dimensions in mm
R = feed direction

PCB terminal block, 2059 Series, black

Connect conductors quickly and safely with this PCB terminal block (item number 2059-321/998-403). It is a universal connector that can be used practically anywhere, for example, as a pluggable PCB connector, panel feedthrough header, connector for rail-mount terminal blocks, or a floating connector for different mounting methods. Conductors should only be connected to this PCB terminal block if their strip length is between 4 and 5.5 mm. This product features one conductor terminal and utilizes PUSH WIRE®. Our proven PUSH WIRE® connection offers the fastest method for clamping conductors. It utilizes the conductor's stiffness to overcome the clamping spring's contact force. Dimensions: (2.9 x 2.7 x 7.9) mm (width x height x depth). Depending on the conductor type, this PCB terminal block is suitable for conductor cross sections ranging from 0.14 mm² to 0.34 mm² on one side and for conductor cross sections from 0.5 mm² to 0.5 mm² on the other side.

Tin is used for coating the contact surfaces. This PCB terminal block is operated with an operating tool. The PCB terminal block is designed for SMD soldering. Insert the conductor into the board at a 0° angle..

The 2059 Series SMD PCB Terminal Block is the smallest 2.7 mm terminal block with an insulated plastic housing in the portfolio. The white housing is perfect for use in LED lights and provides minimal shadowing thanks to its small design with rounded corners. WAGO's 2059 Series design is accented by a clean look and characteristic round hole for the operating tool for disconnecting conductors. Thanks to the slim design, terminal blocks can be arranged side-by-side without pole loss and without limitation. The slightly slanted shape of the terminal block front with the balcony-like projection of the underside not only allows a good view from above of the conductor entry hole, it also enables quick and easy insertion of solid conductors.

Notes

Note

Application notes:

Suitable for lead-free, reflow-soldering profiles per DIN EN 61760-1 and IEC 60068-2-58 up to max. 260°C peak temperature. Due to application-specific variables (component configuration and orientation, type of soldering machine, solder paste), trial runs are recommended to ensure product and process compatibility under actual manufacturing conditions.

Depending on reflow soldering temperatures and times, color deviations may occur. These deviations will have no impact on functionality.

Recommendation

Recommendation for stencil:

150 µm material thickness; Pattern layout identical to solder pad layout

Electrical data

Ratings per	IEC/EN 60664-1			Approvals per	UL 1977
Overvoltage category	III	III	II	Rated voltage	600 V
Pollution degree	3	2	2	Rated current	3 A
Nominal voltage	63 V	160 V	320 V		
Rated impulse withstand voltage	2.5 kV	2.5 kV	2.5 kV		
Rated current	3 A	3 A	3 A		

Connection Data

Clamping units	1
Total number of potentials	1
Number of connection types	1
Number of levels	1

Connection 1

Connection technology	PUSH WIRE®
Actuation type	Operating tool
Solid conductor	0.14 ... 0.34 mm ² / 26 ... 22 AWG
Note (conductor cross-section)	For conductors (26 AWG) that are not rigid enough, the clamping unit must be opened using an operating tool.
Strip length	4 ... 5.5 mm / 0.16 ... 0.22 inches
Conductor connection direction to PCB	0°
Pole number	1

Connection 2

Solid conductor	0.5 mm ² / 20 AWG
Note (conductor cross-section)	No reconnection of smaller conductor cross-sections (0.5 mm ² /20 AWG)
Strip length	6 ... 7.5 mm / 0.24 ... 0.3 inches

Physical data

Pin spacing	3 mm / 0.118 inches
Width	2.9 mm / 0.114 inches
Height	2.7 mm / 0.106 inches
Depth	7.9 mm / 0.311 inches
Reel diameter of tape-and-reel packaging	330 mm
Tape width	16 mm

PCB contact

PCB contact	SMD
Solder pin arrangement	over the entire terminal strip (in-line)
Number of solder pins per potential	2

Material data

Note (material data)	Information on material specifications can be found here
Color	black
Material group	I
Insulation material (main housing)	Polyphthalamide (PPA GF)
Flammability class per UL94	V0
Contact material	Copper alloy
Contact Plating	Tin
Fire load	0.004 MJ
Weight	0.1 g

Environmental requirements

Limit temperature range	-60 ... +105 °C
-------------------------	-----------------

Environmental Testing

Test specification: Railway applications – Rolling stock – Electronic equipment	DIN EN 50155 (VDE 0115-200):2022-06
Test procedure: Railway applications – Rolling stock equipment – Vibration and shock tests	DIN EN 61373 (VDE 0115-0106):2011-04
Spectrum/Mounting location	Service life test, Category 1, Class A/B
Functional test with noise-like oscillations	Test passed according to Section 8 of the standard
Frequency	$f_1 = 5 \text{ Hz}$ to $f_2 = 150 \text{ Hz}$
Acceleration	0.101g (highest test level used for all axes)
Test duration per axis	10 min.
Test directions	X, Y and Z axes
Monitoring of contact faults and interruptions	Passed
Voltage drop measurement before and after each axis	Passed
Simulated service life test through increased levels of noise-like oscillations	Test passed according to Section 9 of the standard
Frequency	$f_1 = 5 \text{ Hz}$ to $f_2 = 150 \text{ Hz}$
Acceleration	0.572g (highest test level used for all axes)
Test duration per axis	5 h
Test directions	X, Y and Z axes
Extended testing: Monitoring of contact faults and interruptions	Passed
Extended testing: Voltage drop measurement before and after each axis	Passed
Shock test	Test passed according to Section 10 of the standard
Shock pulse form	Half sine
Acceleration	5g (highest test level used for all axes)
Shock duration	30 ms
Number of shocks (per axis)	3 pos. und 3 neg.
Test directions	X, Y and Z axes
Extended testing: Monitoring of contact faults and interruptions	Passed

Environmental Testing

Extended testing: Voltage drop measurement before and after each axis	Passed
Vibration and shock stress for rolling stock equipment	Passed

Commercial data

PU (SPU)	31800 (2650) pcs
Packaging type	Box
Country of origin	CH
GTIN	4055143476584
Customs tariff number	85369010000

Product Classification

UNSPSC	39121409
eCl@ss 10.0	27-14-11-06
eCl@ss 9.0	27-14-11-06
ETIM 9.0	EC001284
ETIM 10.0	EC001284
ECCN	NO US CLASSIFICATION

Environmental Product Compliance

RoHS Compliance Status	Compliant, No Exemption
------------------------	-------------------------

Approvals / Certificates

General approvals



Approval	Standard	Certificate Name
CCA DEKRA Certification B.V.	EN 60947-7-4	NTR NL-7819
CCA DEKRA Certification B.V.	EN 60947-7-4	71-111131
CCA DEKRA Certification B.V.	EN 60838	NTR NL-7720
KEMA/KEUR DEKRA Certification B.V.	EN 60838	71-106226

Declarations of conformity and manufacturer's declarations



Approval	Standard	Certificate Name
Railway WAGO GmbH & Co. KG	-	Z00004395.000

Downloads

Environmental Product Compliance

Compliance Search

Environmental Product Compliance 2059-321/998-403	↓
--	-------------------

Documentation

Additional Information

Technical Section	03.04.2019	pdf 2027.26 KB	
-------------------	------------	-------------------	--

CAD/CAE-Data

CAD data	PCB Design
2D/3D Models 2059-321/998-403	Symbol and Footprint via SamacSys 2059-321/998-403
	Symbol and Footprint via Ultra Librarian 2059-321/998-403

1 Compatible Products

1.1 Optional Accessories

1.1.1 Board-to-board link

1.1.1.1 Board-to-board link



Item No.: 2059-901

Board-to-Board Link; Pin spacing 3 mm;
1-pole; Length: 15.3 mm; white



Item No.: 2059-901/018-000

Board-to-Board Link; Pin spacing 3 mm;
1-pole; Length: 17.5 mm; white



Item No.: 2059-901/021-000

Board-to-Board Link; Pin spacing 3 mm;
1-pole; Length: 20.5 mm; white

1.1.2 Tool

1.1.2.1 Operating tool



Item No.: 206-859

Operating tool; for 2059 Series; multicoloured



Item No.: 2059-189

Operating tool; made of insulating material; for 2059 Series

Installation Notes

Conductor termination



Insert solid conductors via push-in termination.

Conductor termination

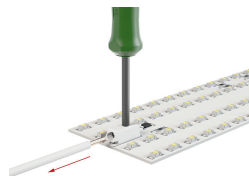

Easy conductor removal, e.g., via operating tool (Item No. 206-859) or "twist & pull" (max. 10 x, no reconnection of smaller conductors possible)