

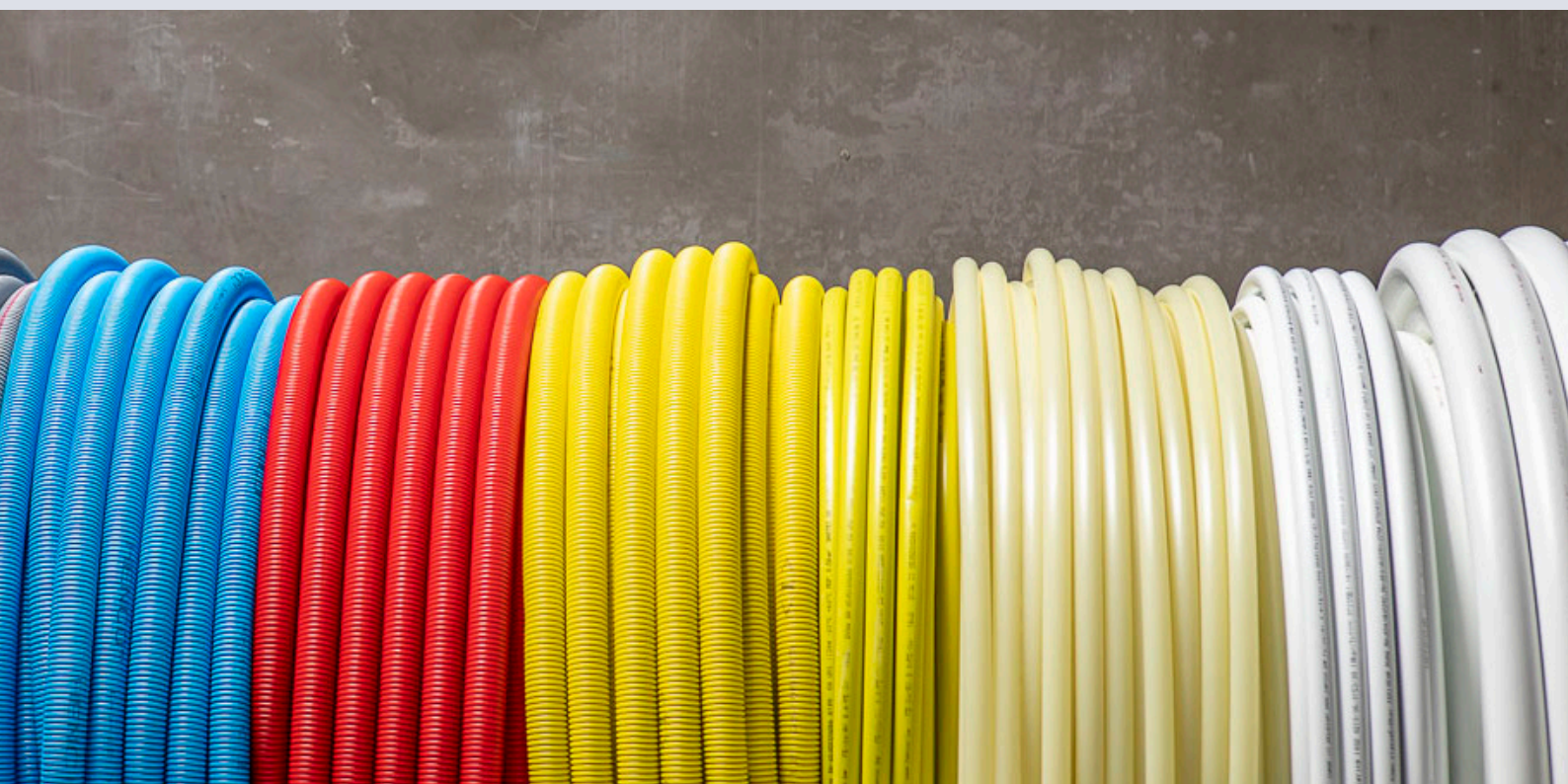

NL

HENCO MEERLAGENBUIS



WE CARE TO CONNECT

Henco Industries NV
Belgium

Toekomstlaan 27
2200 Herentals

+32 14 28 56 60
info@henco.be



HENCO MEERLAGENBUIS PE-XC/ALUMINIUM/PE-XC

HENCO met alle voordelen van kunststof en metaal

- ✓ Gelaste aluminium buis
- ✓ 100% zuurstofdicht en waterdampdiffusiedicht
- ✓ Lage lineaire uitzettingscoëfficiënt, vergelijkbaar met metalen buis
- ✓ Volledig corrosiebestendig, ook bestand tegen chemische en elektrochemische stoffen
- ✓ Geluidsisolatie vergelijkbaar met volledig Kunststof buis
- ✓ Door middel van elektronenstralen vernette binnen- en buitenbuis
- ✓ Hoge weerstand tegen druk en temperatuur
- ✓ Glad oppervlak, minder drukverlies
- ✓ Zo licht als kunststof buizen
- ✓ Flexibel, gemakkelijk te buigen, zelfs bij lage temperaturen, vormvast na het buigen



Verwarming en koeling



Drinkwater



Regenwater



Gas



Samengeperste lucht



Stookolie



Technisch profiel Henco meerlagenbuis

Diameter (mm)	12	14	16	16	18	18	20	20	26	26	32	40	50	63	75	90
				RiXc		RiXc		RiXc		RiXc						
Binnendiameter (mm)	8,8	10	12	12	14	14	16	16	20	20	26	33	42	54	63	76
Wanddikte (mm)	1,6	2	2	2	2	2	2	2	3	3	3	3,5	4,0	4,5	6	7
Max. werktemperatuur (°C)	60	95	95	95	95	95	95	95	95	95	95	95	95	95	95	95
Max. werkdruk (bar)	6	10	16	10	10	10	16	10	16	10	16	10	10	10	10	10
Warmtegeleiding (W/mK)	0,43	0,43	0,43	0,43	0,43	0,43	0,43	0,43	0,43	0,43	0,43	0,43	0,43	0,43	0,43	0,43
Lineaire uitzetting (mm/mK)	0,025	0,025	0,025	0,025	0,025	0,025	0,025	0,025	0,025	0,025	0,025	0,025	0,025	0,025	0,025	0,025
Minimum treksterkte van lijmlaag (N/10mm)	30	30	30	30	30	30	30	30	30	30	30	30	30	30	30	30
Oppervlakterutheid van binnenbuis (µ)	7	7	7	7	7	7	7	7	7	7	7	7	7	7	7	7
Zuurstofdiffusie (mg/l)	0	0	0	0	0	0	0	0	0	0	0	0	0	0	0	0
Min. buigradius, manuele/externe spiraalveer (mm)	5XDu	5XDu	5XDu	5XDu	5XDu	5XDu	5XDu	5XDu	5XDu	5XDu	*	*	*	*	*	*
Min. buigradius, manuele/externe spiraalveer (mm)	3XDu	3XDu	3XDu+	3XDu+	3XDu	3XDu	3XDu	3XDu	3XDu	3XDu	*	*	*	*	*	*
Vernettingsgraad (%)	60	60	60	60	60	60	60	60	60	60	60	60	60	60	60	60
Gewicht (kg/m)	0,084	0,108	0,125	0,101	0,132	0,125	0,147	0,129	0,285	0,261	0,39	0,528	0,766	1,155	1,516	2,155
Volume (l/m)	0,061	0,079	0,113	0,113	0,154	0,154	0,201	0,201	0,314	0,314	0,531	0,855	1,385	2,29	3,117	4,536
Toepassingsklasse (EN ISO21003-1)	4	2-4-5	2-4-5	2-4-5	2-4-5	2-4-5	2-4-5	2-4-5	2-4-5	2-4-5	2-4-5	2-4-5	2-4-5	2-4-5	2-4-5	2-4-5

* Hier moeten kniefittingen worden gebruikt

+ 2XDU bij gebruik van een BM-16 buiggereedschap

HENCO MEERLAGENBUIIS EN FITTINGEN: EEN CORROSIEVRIJ SYSTEEM

Henco kunststof persfittingen (Ø14-63)

Leak Before Press Lekdetectie (Ø14-90)

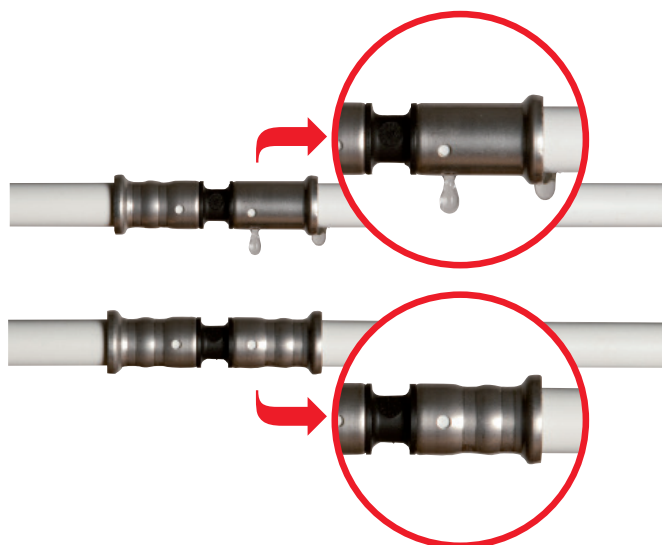
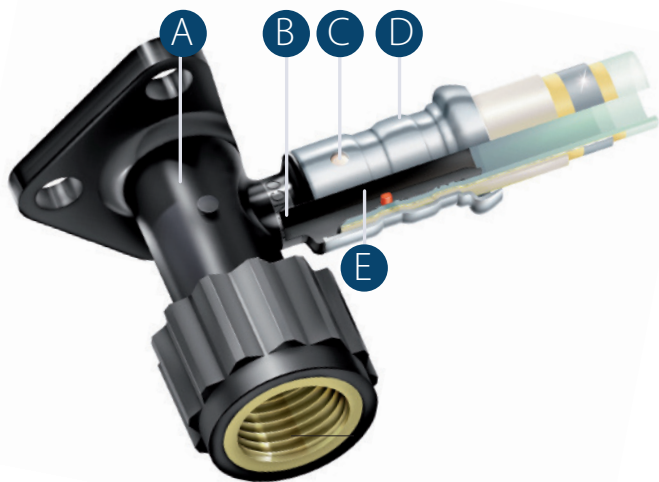

- A** Verbindingslichaam van synthetisch materiaal
- B** Kijkvenster om te controleren of de buis er volledig in zit
- C** Roestvrij stalen schouder om in de bekken van het persgereedschap
- D** Drukhuls van roestvrij staal
- E** Flexibele O-ring gemaakt van EPDM

1 SNIJ



2 KALIBREER

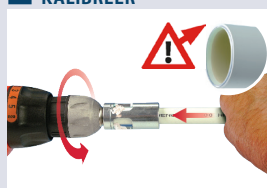

3 PERS



Henco Vision Synthetische push fittingen (Ø16-20-26)

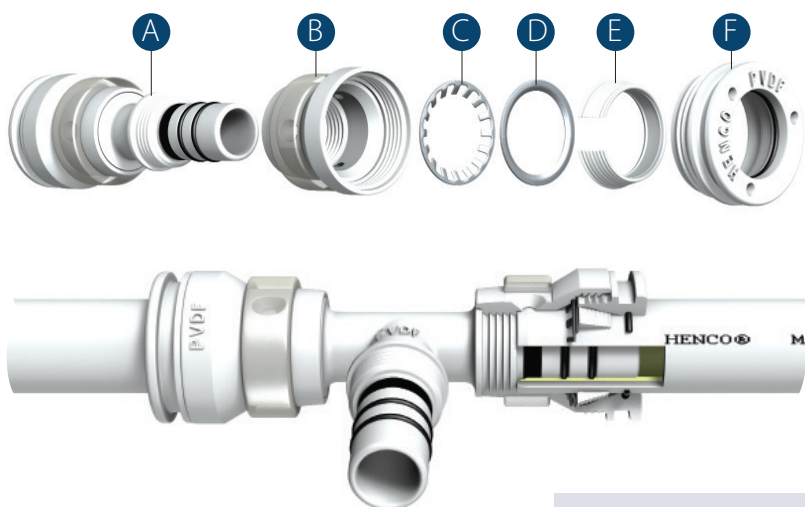

- A** Kunststof behuizing met 2 EPDM O-ringen
- B** Kunststof huiss met kijkvensters
- C** Roestvrij stalen grijping
- D** Roestvrij stalen steuning
- E** Conische kunststof sluitring
- F** Kunststof schroefmoer met EPDM O-ring en 3 demontage inkepingen

Snel demonteerbaar!

1 SNIJ



2 KALIBREER

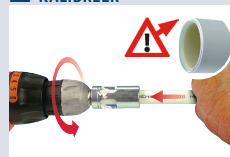

3 DRUK



HENCO FULL FLOW MANIFOLD: EEN VOLLEDIG MODULAIR SYSTEEM IN KUNSTSTOF

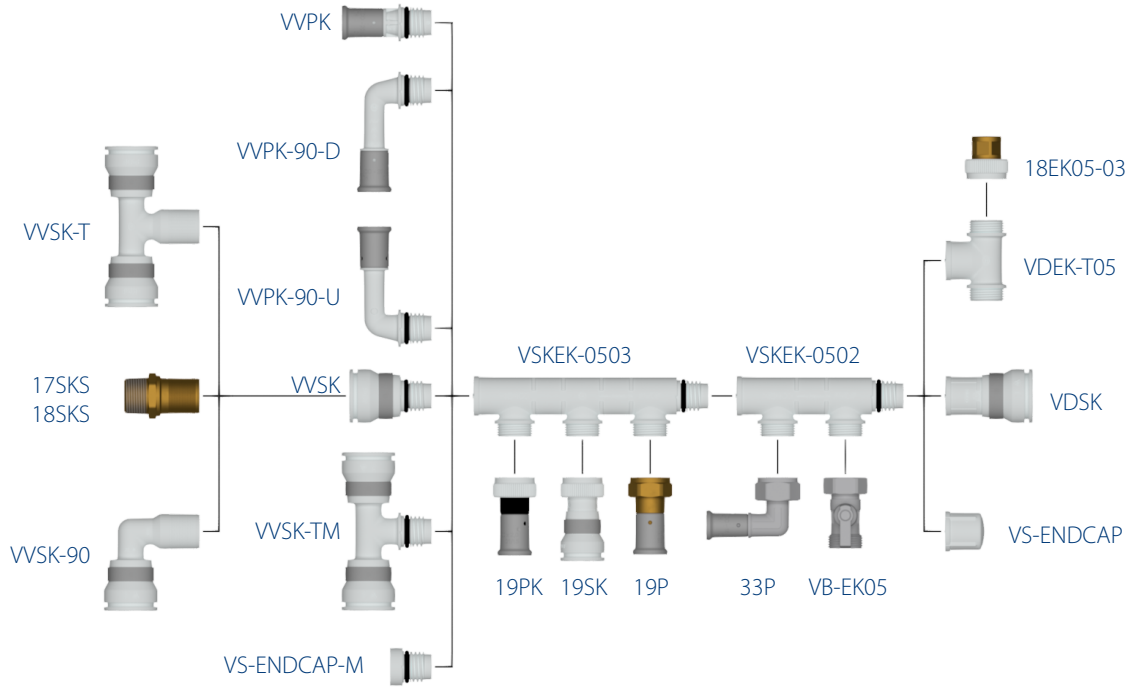

Henco
meerlagenbuis



Henco meerlagenbuis
met doorvoer



Henco voorgeïsoleerde
meerlagenbuis



Henco meerlagenbuis
met doorvoer voor gas*



Henco Combi



Henco Combi Iso

* Alleen toegestaan in landen waar een HENCO GAS goedkeuring + certificaat beschikbaar is. (zie www.henco.be)

CERTIFICATEN OVER DE HELE WERELD BEVESTIGEN DE TOPKWALITEIT VAN HENCO



HENCO 10 JAAR SYSTEEMGARANTIE

Henco Industries NV
Belgium

Toekomstlaan 27
2200 Herentals

+32 14 28 56 60
info@henco.be

