

PowerXL™

DG1 Variable Frequency Drives PID Controller



Level 3	<ul style="list-style-type: none">1 – Fundamental – No previous experience necessary2 – Basic – Basic knowledge recommended3 – Advanced – Reasonable knowledge required4 – Expert – Good experience recommended
---------	--

EATON

Powering Business Worldwide

Contents

1	General	5
2	Controller Enable.....	6
3	Set Point Circuit	7
3.1	Selection of the set point channel and setting the ramp time.....	7
3.2	Selection of the set point source, upper and lower limits	8
3.3	Compensation of flow losses.....	10
3.4	Scaling the set point value.....	11
4	Feedback circuit.....	12
4.1	Selection of the feedback source, upper and lower limits.....	12
4.2	Interconnection of the feedback channels 1 and 2.....	14
4.3	Scaling the feedback value	15
5	PID Controller	16
5.1	Setting the control parameters	16
5.2	Inverting the control deviation	18
5.3	Feedforward	19
5.3.1	Selection of the feedforward source, upper and lower limits	19
5.3.2	Interconnection of the feedforward signals.....	21
5.3.3	Scaling the feedforward signal	23
5.4	Dead band	23
5.5	Sleep mode.....	23
5.5.1	Settings when using „PID Set Point 1“	24
5.5.2	Settings when using „PID Set Point 2“	25
5.5.3	General procedure. Example for PID1 Set Point 1	26
5.5.4	Parameters used in sleep mode	27
6	Process units.....	28
6.1	Configuration example for controller PID1:	29
7	Signaling	31
7.1	Exceeding the error value	31
7.2	Feedback loss	32

Danger! - Dangerous electrical voltage!

- Disconnect the power supply of the device.
- Ensure that devices cannot be accidentally restarted.
- Verify isolation from the supply.
- Cover or enclose any adjacent live components.
- Follow the engineering instructions (AWA/IL) for the device concerned.
- Only suitably qualified personnel in accordance with EN 50110-1/-2 (VDE 0105 Part 100) may work on this device/system.
- Before installation and before touching the device ensure that you are free of electrostatic charge.
- The functional earth (FE, PES) must be connected to the protective earth (PE) or the potential equalization. The system installer is responsible for implementing this connection.
- Connecting cables and signal lines should be installed so that inductive or capacitive interference does not impair the automatic control functions.
- Suitable safety hardware and software measures should be implemented for the I/O interface so that an open circuit on the signal side does not result in undefined states.
- Deviations of the mains voltage from the rated value must not exceed the tolerance limits given in the specification, otherwise this may cause malfunction and/or dangerous operation.
- Emergency stop devices complying with IEC/EN 60204-1 must be effective in all operating modes. Unlatching of the emergency-stop devices must not cause a restart.
- Devices that are designed for mounting in housings or control cabinets must only be operated and controlled after they have been properly installed and with the housing closed.
- Wherever faults may cause injury or material damage, external measures must be implemented to ensure a safe operating state in the event of a fault or malfunction (e.g. by means of separate limit switches, mechanical interlocks etc.).
- Frequency inverters may have hot surfaces during and immediately after operation.
- Removal of the required covers, improper installation or incorrect operation of motor or frequency inverter may destroy the device and may lead to serious injury or damage.
- The applicable national safety regulations and accident prevention recommendations must be applied to all work carried on live frequency inverters.
- The electrical installation must be carried out in accordance with the relevant electrical regulations (e. g. with regard to cable cross sections, fuses, PE).
- Transport, installation, commissioning and maintenance work must be carried out only by qualified personnel (IEC 60364, HD 384 and national occupational safety regulations).
- Installations containing frequency inverters must be provided with additional monitoring and protective devices in accordance with the applicable safety regulations. Modifications to the frequency inverters using the operating software are permitted.
- All covers and doors must be kept closed during operation.
- To reduce the hazards for people or equipment, the user must include in the machine design measures that restrict the consequences of a malfunction or failure of the frequency inverter (increased motor speed or sudden standstill of motor). These measures include: – Other independent devices for monitoring safety related variables (speed, travel, end positions etc.).
 - Electrical or non-electrical system-wide measures (electrical or mechanical interlocks).

Never touch live parts or cable connections of the frequency inverter after it has been disconnected from the power supply. Due to the charge in the capacitors, these parts may still be alive after disconnection. Consider appropriate warning signs

Disclaimer

The information, recommendations, descriptions, and safety notations in this document are based on Eaton's experience and judgment and may not cover all contingencies. If further information is required, an Eaton sales office should be consulted. Sale of the product shown in this literature is subject to the terms and conditions outlined in the applicable Terms and Conditions for Sale of Eaton or other contractual agreement between Eaton and the purchaser. THERE ARE NO UNDERSTANDINGS, AGREEMENTS, WARRANTIES, EXPRESSED OR IMPLIED, INCLUDING WARRANTIES OF FITNESS FOR A PARTICULAR PURPOSE OR MERCHANTABILITY, OTHER THAN THOSE SPECIFICALLY SET OUT IN ANY EXISTING CONTRACT BETWEEN THE PARTIES. ANY SUCH CONTRACT STATES THE ENTIRE OBLIGATION OF EATON. THE CONTENTS OF THIS DOCUMENT SHALL NOT BECOME PART OF OR MODIFY ANY CONTRACT BETWEEN THE PARTIES. As far as applicable mandatory law allows so, in no event will Eaton be responsible to the purchaser or user in contract, in tort (including negligence), strict liability, or otherwise for any special, indirect, incidental, or consequential damage or loss whatsoever, including but not limited to damage or loss of use of equipment, plant or power system, cost of capital, loss of power, additional expenses in the use of existing power facilities, or claims against the purchaser or user by its customers resulting from the use of the information, recommendations, and descriptions contained herein. The information contained in this manual is subject to change without notice.

1 General

The variable frequency drives of the series **PowerXL™ DG1** have two internal PID controllers, which permit to control the speed of the motor depending on process variables like pressure, temperature....

This Application Note describes

- the function of the specific parameters
- the operation method of the controllers
- application examples

General structure:

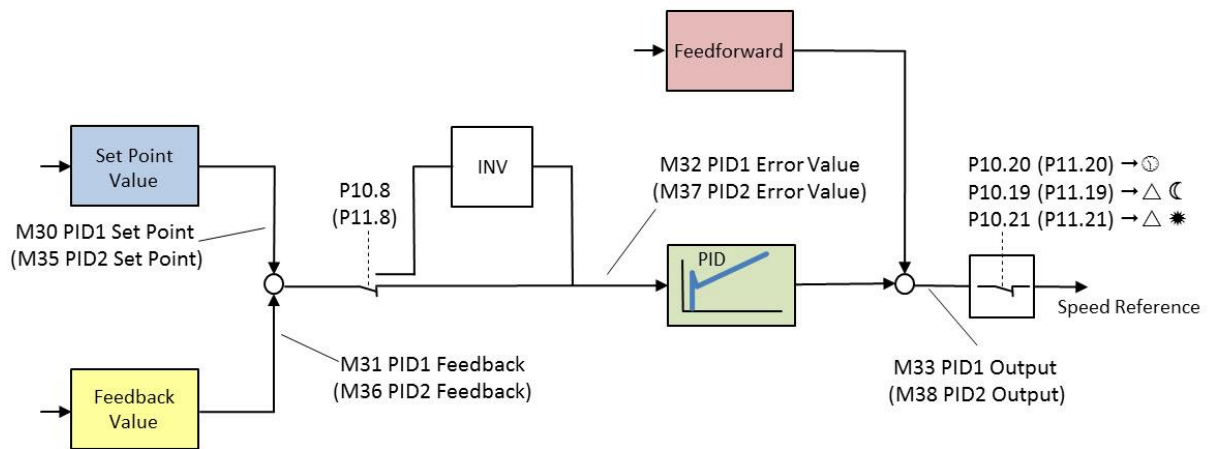

It is a PID controller with

- separately adjustable gains and time constants
- set point and feedback circuit with adaptability to the different signals
- feedforward circuit for improved response times
- the possibility to invert the error value
- dead band for a stable operation at small error values
- standby mode (sleep-mode)

The functions described here, refer to an application software version 1.02.0032 and above (see parameter P21.2.3). It is available in the following applications (P21.1.2):

P21.1.2	Application	PID controller PID1	PID controller PID2
0	Standard	No	No
1	Multi-Pump	Yes	No
2	Multi-PID	Yes	Yes
3	Multi-Purpose	Yes	Yes

The structure of both controllers is the same one. The information inside this Application Note refer to the PID controller PID1, whose parameters can be found in parameter group P10 (P10. ...). The descriptions are equally valid for the PID controller PID2. Parameters for this controller are inside the parameter group P11 (P11. ...).

2 Controller Enable

To operate a PID controller, it has to be enabled. The source of the enable signal is determined by P3.13 resp. P3.14. When the controller is disabled, the values for the set point, feedback, error value and the output value of the controller are forced to zero (M30 to M33 resp. M35 to M38). The Status is displayed with M34 “PID1 Status” resp. M39 „PID2 Status“.

Source P3.13 resp. P3.14	Status	Display M34 resp. M39
LOW	controller disabled	Stopped (0)
HIGH	controller enabled	Running (1)

Parameter	Name	Range	Default
P3.13 (P3.14)	PID1 Control Enable (PID2 Control Enable)	DigIN:NormallyOpen (0) DigIN:NormallyClose (1) DigIN 1 (2) DigIN 2 (3) DigIN 3 (4) DigIN 4 (5) DigIN 5 (6) DigIN 6 (7) DigIN 7 (8) DigIN 8 (9) DigIN: A: IO1: 1 (10) (on DXG-EXT-3DI3DO1T) DigIN: A: IO1: 2 (11) (on DXG-EXT-3DI3DO1T) DigIN: A: IO1: 3 (12) (on DXG-EXT-3DI3DO1T) DigIN: A: IO5: 1 (13) (on DXG-EXT-6DI) DigIN: A: IO5: 2 (14) (on DXG-EXT-6DI) DigIN: A: IO5: 3 (15) (on DXG-EXT-6DI) DigIN: A: IO5: 4 (16) (on DXG-EXT-6DI) DigIN: A: IO5: 5 (17) (on DXG-EXT-6DI) DigIN: A: IO5: 6 (18) (on DXG-EXT-6DI) DigIN: B: IO1: 1 (19) (on DXG-EXT-3DI3DO1T) DigIN: B: IO1: 2 (20) (on DXG-EXT-3DI3DO1T) DigIN: B: IO1: 3 (21) (on DXG-EXT-3DI3DO1T) DigIN: B: IO5: 1 (22) (on DXG-EXT-6DI) DigIN: B: IO5: 2 (23) (on DXG-EXT-6DI) DigIN: B: IO5: 3 (24) (on DXG-EXT-6DI) DigIN: B: IO5: 4 (25) (on DXG-EXT-6DI) DigIN: B: IO5: 5 (26) (on DXG-EXT-6DI) DigIN: B: IO5: 6 (27) (on DXG-EXT-6DI) Time Channel 1 (28) Time Channel 2 (29) Time Channel 3 (30) RO1 Function (31) RO2 Function (32) RO3 Function (33) Virtual RO1 Function (34) Virtual RO2 Function (35)	DigIN:Normally Close (1)

3 Set Point Circuit

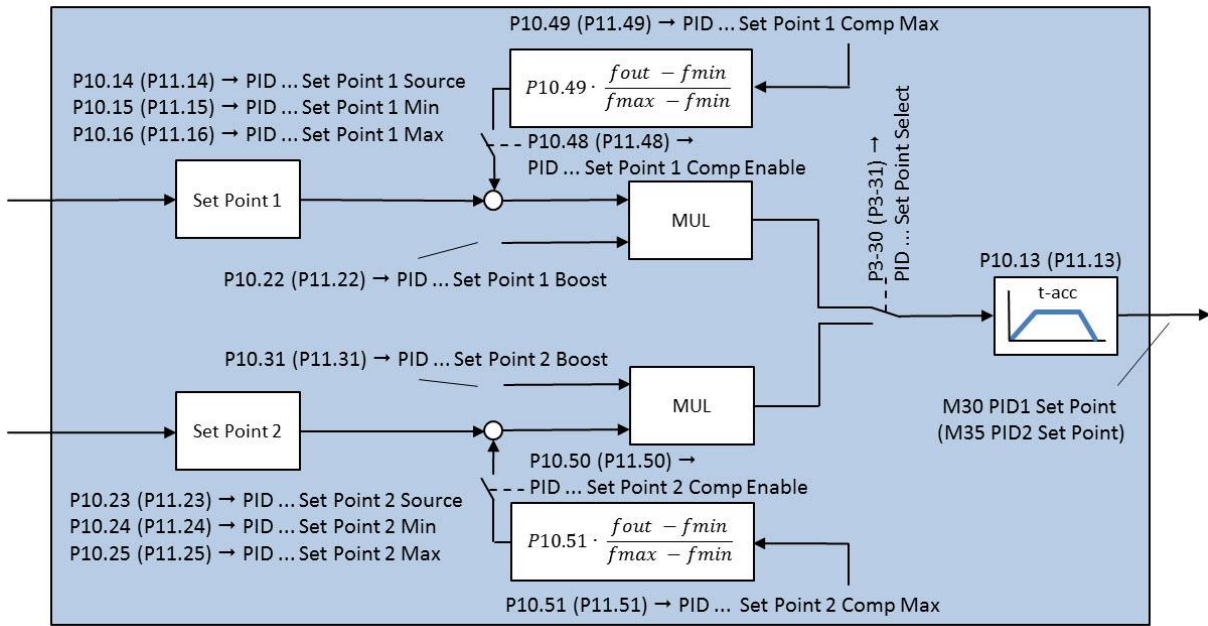

3.1 Selection of the set point channel and setting the ramp time

The set point circuit of the PID controller consists out of two identical channels (Set Point 1 and Set Point 2). A digital signal determines, which channel is the active one. When changing set point values or at a changeover between the set point channels the ramp, set with P10.13 (P11.13), is active.

P3-30 „PID1 Set Point Select“

P3-31 „PID2 Set Point Select“

Selection between the set point channels Set Point 1 and Set Point 2.

- LOW Signal → Set Point 1
- HIGH Signal → Set Point 2

P10-13 “PID1 Ramp Time”

P11-13 “PID2 Ramp Time”

Ramp time of the set point. The ramp time is active at an increase as well as at a decrease of the set point value. It refers to the range between the minimum (P10.15 P11.15) and the maximum set point (P10.16 P11.16).

Parameter	Name	Range	Default
P3.30 (P3.31)	PID1 Set Point Select (PID2 Set Point Select)	DigIN:NormallyOpen (0) DigIN:NormallyClose (1) DigIN 1 (2) DigIN 2 (3) DigIN 3 (4) DigIN 4 (5) DigIN 5 (6) DigIN 6 (7) DigIN 7 (8) DigIN 8 (9) DigIN: A: IO1: 1 (10) (on DXG-EXT-3DI3DO1T) DigIN: A: IO1: 2 (11) (on DXG-EXT-3DI3DO1T)	DigIN: NormallyOpen (0)

Parameter	Name	Range	Default
		DigIN: A: IO1: 3 (12) (on DXG-EXT-3DI3DO1T) DigIN: A: IO5: 1 (13) (on DXG-EXT-6DI) DigIN: A: IO5: 2 (14) (on DXG-EXT-6DI) DigIN: A: IO5: 3 (15) (on DXG-EXT-6DI) DigIN: A: IO5: 4 (16) (on DXG-EXT-6DI) DigIN: A: IO5: 5 (17) (on DXG-EXT-6DI) DigIN: A: IO5: 6 (18) (on DXG-EXT-6DI) DigIN: B: IO1: 1 (19) (on DXG-EXT-3DI3DO1T) DigIN: B: IO1: 2 (20) (on DXG-EXT-3DI3DO1T) DigIN: B: IO1: 3 (21) (on DXG-EXT-3DI3DO1T) DigIN: B: IO5: 1 (22) (on DXG-EXT-6DI) DigIN: B: IO5: 2 (23) (on DXG-EXT-6DI) DigIN: B: IO5: 3 (24) (on DXG-EXT-6DI) DigIN: B: IO5: 4 (25) (on DXG-EXT-6DI) DigIN: B: IO5: 5 (26) (on DXG-EXT-6DI) DigIN: B: IO5: 6 (27) (on DXG-EXT-6DI) Time Channel 1 (28) Time Channel 2 (29) Time Channel 3 (30) RO1 Function (31) RO2 Function (32) RO3 Function (33) Virtual RO1 Function (34) Virtual RO2 Function (35)	
P10.13 (P11.13)	PID1 Ramp Time (PID2 Ramp Time)	0 – 300 s	0.00 s

3.2 Selection of the set point source, upper and lower limits

Both set point channels described in 3.1 offer the possibility to take different operating conditions during control into account. In channel 1 an external analog value can be used for example, while channel 2 provides a fixed value, set internally. The parameters P10.14 (P11.14) “PID ... Set Point 1 Source” and P10.23 (P11.23) „PID ... Set Point 2 Source” determine the way, how the set point value is applied to the control. In addition the upper and lower limits of the set point value can be set separately for each channel.

P10.11 „PID1 Keypad Set Point 1“

P11.11 „PID2 Keypad Set Point 1“

Set point at P10.14 resp. P10.23 (P11.14 resp. P11.23) = PID1 Keypad Set Point 1 (1) (PID2 Keypad Set Point 1 (1)). In this case the set point of the process variable is constant.

P10.12 „PID1 Keypad Set Point 2“

P11.12 „PID2 Keypad Set Point 2“

Set point at P10.14 resp. P10.23 (P11.14 resp. P11.23) = PID1 Keypad Set Point 2 (2) (PID2 Keypad Set Point 2 (2)). In this case the set point of the process variable is constant.

P10.14 „PID1 Set Point 1 Source“

P11.14 „PID2 Set Point 1 Source“

This parameter determines, which source provides set point 1.

Not used (0):	Set point channel 1 of the controller is not used
PID1 Keypad Set Point 1 (1): (PID2 Keypad Set Point 1 (1))	The set point value is constant, determined by P10.11 (P11.11)
PID1 Keypad Set Point 2 (2): (PID2 Keypad Set Point 2 (2))	The set point value is constant, determined by P10.12 (P11.12)
AI1 (3):	The set point value comes from analog input AI1.
AI2 (4):	The set point value comes from analog input AI2.
Slot A: AI1 (5):	The set point value comes from analog input AI1 on DXG-EXT-1AI2AO in Slot A.
Slot B: AI1 (6):	The set point value comes from analog input AI1 on DXG-EXT-1AI2AO in Slot B.
FB Process Data Input 1...8 (7-14)	The set point value comes from fieldbus process data input 1 ... 8.
PID2 Output (15) at PID1 PID1 Output (15) at PID2	The set point value comes from the output of PID controller 2. (The set point value comes from the output of PID controller 1.)

P10.15 „PID1 Set Point 1 Min“

P11.15 „PID2 Set Point 1 Min“

Minimum value of set point 1. Application example see Chapter 6.1.

P10.16 „PID1 Set Point 1 Max“

P11.16 „PID2 Set Point 1 Max“

Maximum value of set point 1. Application example see Chapter 6.1.

P10.23 „PID1 Set Point 2 Source“

P11.23 „PID2 Set Point 2 Source“

This parameter determines, which source provides set point 2.

Not used (0):	Set point channel 1 of the controller is not used
PID1 Keypad Set Point 1 (1): (PID2 Keypad Set Point 1 (1))	The set point value is constant, determined by P10.11 (P11.11)
PID1 Keypad Set Point 2 (2): (PID2 Keypad Set Point 2 (2))	The set point value is constant, determined by P10.12 (P11.12)
AI1 (3):	The set point value comes from analog input AI1.
AI2 (4):	The set point value comes from analog input AI2.
Slot A: AI1 (5):	The set point value comes from analog input AI1 DXG-EXT-1AI2AO in Slot A.
Slot B: AI1 (6):	The set point value comes from analog input AI1 DXG-EXT-1AI2AO in Slot B.
FB Process Data Input 1...8 (7-14)	The set point value comes from fieldbus process data input 1 ... 8.
PID2 Output (15) at PID1 PID1 Output (15) at PID2	The set point value comes from the output of PID controller 2. (The set point value comes from the output of PID controller 1.)

P10.24 „PID1 Set Point 2 Min“

P11.24 „PID2 Set Point 2 Min“

Minimum value of set point 1. Application example see Chapter 6.1.

P10.25 „PID1 Sollwert 2 Max“

P11.25 „PID2 Sollwert 2 Max“

Maximum value of set point 1. Application example see Chapter 6.1.

Parameter	Name	Range	default
P10.11 (P11.11)	PID1 Keypad Set Point 1 (PID2 Keypad Set Point 1)	P10.5 – P10.6, see chapter 6 (P11.5 – P11.6)	0.00
P10.12 (P11.12)	PID1 Keypad Set Point 2 (PID2 Keypad Set Point 2)	P10.5 – P10.6, see chapter 6 (P11.5 – P11.6)	0.00
P10.14 (P11.14)	PID1 Set Point 1 Source (PID2 Set Point 1 Source)	Not Used (0) PID1 Keypad Set Point 1 (1) PID1 Keypad Set Point 2 (2) AI1 (3) AI2 (4) Slot A: AI1 (5) AI1 on DXG-EXT-1AI2AO in Slot A Slot B: AI1 (6) AI1 on DXG-EXT-1AI2AO in Slot B FB Process Data Input 1 (7) FB Process Data Input 2 (8) FB Process Data Input 3 (9) FB Process Data Input 4 (10) FB Process Data Input 5 (11) FB Process Data Input 6 (12) FB Process Data Input 7 (13) FB Process Data Input 7 (14) PID2 Output (15) at PID1 PID1 Output (15) at PID2 Multi Drive Network (16)	1
P10.15 (P11.15)	PID1 Set Point 1 Min (PID2 Set Point 1 Min)	-200 % ... 200 %	0.00 %
P10.16 (P11.16)	PID1 Set Point 1 Max (PID2 Set Point 1 Max)	-200 % ... 200 %	100.00 %
P10.23 (P11.23)	PID1 Set Point 2 Source (PID2 Set Point 2 Source)	like P10.14 (like P11.14)	2
P10.24 (P11.24)	PID1 Set Point 2 Min (PID2 Set Point 2 Min)	-200 % ... 200 %	0.00 %
P10.25 (P11.25)	PID1 Set Point 2 Max (PID2 Set Point 2 Max)	-200 % ... 200 %	100.00 %

3.3 Compensation of flow losses

It happens, that the process variable, e.g. pressure, cannot be measured at the place, where a certain value should exist. This leads to wrong results of the control.

Example: The pressure should have a certain value at position A, but can only be measured at position B. Between the two positions is a distance of 10 m, where flow losses occur. This means, that the pressure at position B must be higher by the losses between A and B. The pressure losses are not always constant, but depend on the flow rate.

Devices of the series DG1 have the possibility to increase the pressure depending on the flow rate (means: depending on the motor speed) to compensate the pressure losses.

Set point channel 1:

Enabling the compensation:

P10.48 „PID1 Set Point 1 Comp Enable“ (P11.48 „PID2 Set Point 1 Comp Enable“) = Enabled (1)

Impact of the compensation:

P10.49 „PID1 Set Point 1 Comp Max“ (P11.49 „PID2 Set Point 1 Comp Max“)

$$\text{Compensation} = P10.49 \cdot \frac{f_{out} - f_{min}}{f_{max} - f_{min}}$$

Set point channel 2:

Enabling the compensation:

P10.50 „PID1 Set Point 2 Comp Enable“ (P11.50 „PID2 Set Point 2 Comp Enable“) = Enabled (1)

Impact of the compensation:

P10.51 „PID1 Set Point 2 Comp Max“ (P11.51 „PID2 Set Point 2 Comp Max“)

$$\text{Compensation} = P10.51 \cdot \frac{f_{out} - f_{min}}{f_{max} - f_{min}}$$

Parameter	Name	Range	Default
P10.48 (P11.48)	PID1 Set Point 1 Comp Enable (PID2 Set Point 1 Comp Enable)	Disabled (0) Enabled (1)	0
P10.49 (P11.49)	PID1 Set Point 1 Comp Max (PID2 Set Point 1 Comp Max)	-200 % ... 200 %	0.00 %
P10.50 (P11.50)	PID1 Set Point 2 Comp Enable (PID2 Set Point 2 Comp Enable)	Disabled (0) Enabled (1)	0
P10.51 (P11.51)	PID1 Set Point 2 Comp Max (PID2 Set Point 2 Comp Max)	-200 % ... 200 %	0.00 %

3.4 Scaling the set point value

It is possible to adopt the set point value by using a multiplier. See also block diagram in chapter 3.

Set point channel 1: P10.22 „PID1 Set Point 1 Boost“ (P11.22 „PID2 Set Point 1 Boost“)

Set point channel 2: P10.31 „PID1 Set Point 2 Boost“ (P11.31 „PID2 Set Point 2 Boost“)

Parameter	Name	Range	Default
P10.22 (P11.22)	PID1 Set Point 1 Boost (PID2 Set Point 1 Boost)	-2 ... 2	1.0
P10.31 (P11.31)	PID1 Set Point 2 Boost (PID2 Set Point 2 Boost)	-2 ... 2	1.0

4 Feedback circuit

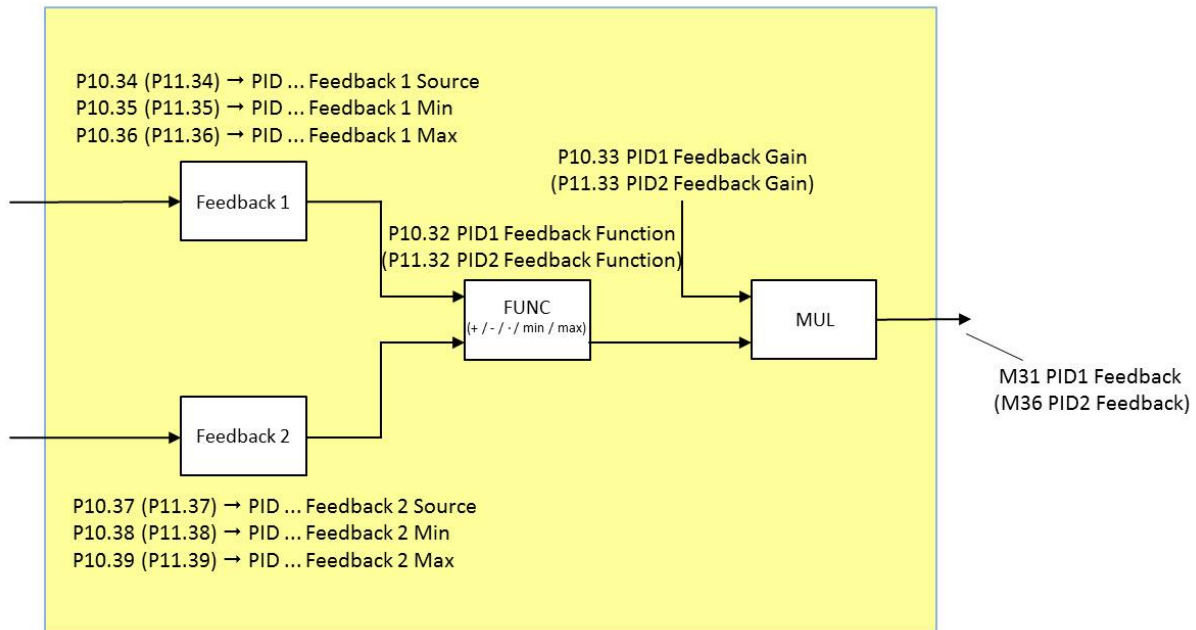

4.1 Selection of the feedback source, upper and lower limits

The devices of the series DG1 have two feedback channels (Feedback 1 and Feedback 2), which can be used separately or in combination. The way of interconnection is described in chapter 4.2.

Parameters P10.34 (P11.34) „PID ... Feedback 1 Source“ and P10.37 (P11.37) „PID ... Feedback 2 Source“ determine the way, how feedback is applied. In addition a minimum and a maximum value of the feedback can be set for both channels separately.

P10.34 „PID1 Feedback 1 Source“

P11.34 „PID2 Feedback 1 Source“

This parameter determines the source of feedback 1.

Not Used (0):	Feedback channel 1 of the controller is not used.
AI1 (1)	The feedback value 1 comes from analog input AI1.
AI2 (2):	The feedback value 1 comes from analog input AI2.
Slot A: AI1 (3):	The feedback value 1 comes from analog input AI1 on DXG-EXT-1AI2AO in Slot A.
Slot B: AI1 (4):	The feedback value 1 comes from analog input AI1 on DXG-EXT-1AI2AO in Slot B.
FB Process Data Input 1 ... 8 (5-12)	The feedback value 1 comes from fieldbus process data input 1...8.
PT100 Temperature (13)	The feedback value 1 is the maximum temperature value among the connected PT100 sensors.
PID2 Output (14): PID1 Output (14):	The feedback value 1 comes from the output of the controller PID2. The feedback value 1 comes from the output of the controller PID1.
SlotA PT100 Temp Channel 1...3 (15 ... 17)	The feedback value 1 comes from PT100 Input 1...3 on DXG-EXT-THER1 in Slot A.
SlotB PT100 Temp Channel 1...3 (18 ... 20)	The feedback value 1 comes from PT100 Input 1...3 on DXG-EXT-THER1 in Slot B.

P10.35 „PID1 Feedback 1 Min“

P11.35 „PID2 Feedback 1 Min“

Minimum value of feedback 1.

P10.36 „PID1 Feedback 1 Max“

P11.36 „PID2 Feedback 1 Max“

Maximum value of feedback 1.

P10.37 „PID1 Feedback 2 Source“

P11.37 „PID2 Feedback 2 Source“

This parameter determines the source of feedback 2.

Not Used (0):	Feedback channel 2 of the controller is not used.
AI1 (1)	The feedback value 2 comes from analog input AI1.
AI2 (2):	The feedback value 2 comes from analog input AI2.
Slot A: AI1 (3):	The feedback value 2 comes from analog input AI1 on DXG-EXT-1AI2AO in Slot A.
Slot B: AI1 (4):	The feedback value 2 comes from analog input AI1 on DXG-EXT-1AI2AO in Slot B.
FB Process Data Input 1 ... 8 (5-12)	The feedback value 2 comes from fieldbus process data input 1...8.
PT100 Temperature (13)	The feedback value 2 is the maximum temperature value among the connected PT100 sensors.
PID2 Output (14):	The feedback value 2 comes from the output of the controller PID2.
PID1 Output (14):	The feedback value 1 comes from the output of the controller PID1.
SlotA PT100 Temp Channel 1...3 (15 ... 17)	The feedback value 2 comes from PT100 Input 1...3 on DXG-EXT-THER1 in Slot A.
SlotB PT100 Temp Channel 1...3 (18 ... 20)	D The feedback value 2 comes from PT100 Input 1...3 on DXG-EXT-THER1 in Slot B.

P10.38 „PID1 Feedback 2 Min“

P11.38 „PID2 Feedback 2 Min“

Minimum value of feedback 2.

P10.39 „PID1 Feedback 2 Max“

P11.39 „PID2 Feedback 2 Max“

Maximum value of feedback 2.

Parameter	Name	Range	Default
P10.34 (P11.34)	PID1 Feedback 1 Source (PID2 Feedback 1 Source)	Not Used (0) AI1 (1) AI2 (2) Slot A: AI1 (3) AI1 on DXG-EXT-1AI2AO in Slot A Slot B: AI1 (4) AI1 on DXG-EXT-1AI2AO in Slot B FB Process Data Input 1 (5) FB Process Data Input 2 (6) FB Process Data Input 3 (7) FB Process Data Input 4 (8) FB Process Data Input 5 (9) FB Process Data Input 6 (10)	2

Parameter	Name	Range	Default
		FB Process Data Input 7 (11) FB Process Data Input 8 (12) PT100 Temperature (13) PID2 Output (14) at PID1 PID1 Output (14) at PID2 SlotA PT100 Temp Channel 1 (15) R1+/RM1/R1- on DXG-EXT-THER1 in Slot A SlotA PT100 Temp Channel 2 (16) R2+/RM2/R2- on DXG-EXT-THER1 in Slot A SlotA PT100 Temp Channel 3 (17) R3+/RM3/R3- on DXG-EXT-THER1 in Slot A SlotB PT100 Temp Channel 1 (18) R1+/RM1/R1- on DXG-EXT-THER1 in Slot B SlotB PT100 Temp Channel 2 (19) R2+/RM2/R2- on DXG-EXT-THER1 in Slot B SlotB PT100 Temp Channel 3 (20) R3+/RM3/R3- on DXG-EXT-THER1 in Slot B	
P10.35 (P11.35)	PID1 Feedback 1 Min (PID2 Feedback 1 Min)	-200 % ... 200 %	0.00 %
P10.36 (P11.36)	PID1 Feedback 1 Max (PID2 Feedback 1 Max)	-200 % ... 200 %	100.00 %
P10.37 (P11.37)	PID1 Feedback 2 Source (PID2 Feedback 2 Source)	like P10.34 (like P11.34)	1
P10.38 (P11.38)	PID1 Feedback 2 Min (PID2 Feedback 2 Min)	-200 % ... 200 %	0.00 %
P10.39 (P11.39)	PID1 Feedback 2 Max (PID2 Feedback 2 Max)	-200 % ... 200 %	100.00 %

4.2 Interconnection of the feedback channels 1 and 2

To control a process variable, a feedback is required. In most of the cases the feedback is a single signal. Depending on the application and the controlled system it can be of advantage, to measure the process variable at multiple (in case of DG1: up to two) places and to interconnect the signals accordingly, before they are applied as feedback to the controller.

Parameter P10.32 "PID1 Feedback Function" (P11.32 "PID2 Feedback Function") determines, in which way the feedback is applied to the controller. It has to be noted, that possibly a scaling with P10.33 (P11.33) is necessary.

Example: In case P10.32 = 4, the feedback signals of source 1 and source 2 are added. When both signals have a value of 100 %, it would lead to 200 % as the result. To ensure comparability with the set point signal, the feedback signal has to be adopted with P10.33 = 50 %.

P10.32 „PID1 Feedback Function“

P11.32 „PID2 Feedback Function“

Source 1 (0)

The feedback value is equivalent to the signal defined with P10.34 (P11.34).

SQRT(Source 1) (1)

The feedback value is equivalent to the square root of source 1.
 Example: Source1 = 100 %
 Feedback value = $\sqrt{100} = 10$ %

SQRT(Source 1 – Source 2) (2)

The feedback value is equivalent to the square root of (Source 1 – Source 2).
 Example: Source 1 = 100 %, Source 2 = 75 %
 Feedback value = $\sqrt{(100 - 75)} = \sqrt{25} = 5$ %

SQRT(Source 1) + SQRT(Source 2) (3)	The feedback value is equivalent to the sum of the square roots of source 1 and source 2. Example: Source 1 = 100 %, Source 2 = 100 % Feedback value = $\sqrt{100} + \sqrt{100} = 10 + 10 = 20$ %
Source 1 + Source 2 (4)	The feedback value is equivalent to the sum of Source 1 and Source 2. Example: Source 1 = 100 %, Source 2 = 100 % Feedback value = 100 + 100 = 200 %
Source 1 – Source 2 (5)	The feedback value is equivalent to the difference Source 1 – Source 2.
MIN(Source 1, Source 2) (6)	The feedback value is equivalent to the smallest value out of Source 1 and Source 2. Example: Source 1 = 20 %, Source 2 = 50 % Feedback value = 20 %
MAX(Source 1, Source 2) (7)	The feedback value is equivalent to the biggest value out of Source 1 and Source 2. Example: Source 1 = 20 %, Source 2 = 50 % Feedback value = 50 %
MEAN(Source 1, Source 2) (8)	The feedback value is equivalent to the mean value out of Source 1 and Source 2. Example: Source 1 = 30 %, Source 2 = 60 % Feedback value = $(30 + 60)/2 = 45$ %

Parameter	Name	Range	Default
P10.32 (P11.32)	PID1 Feedback Function (PID2 Feedback Function)	Source 1 (0) SQRT(Source 1) (1) SQRT(Source 1 – Source 2) (2) SQRT(Source 1) + SQRT (Source 2) (3) Source 1 + Source 2 (4) Source 1 – Source 2 (5) MIN(Source 1, Source 2) (6) MAX(Source 1, Source 2) (7) MEAN (Source 1, Source 2) (8)	0

4.3 Scaling the feedback value

It is possible to adopt the feedback value by using a multiplier. See also block diagram in chapter 4.

P10.33 „PID1 Feedback Gain“ (P11.33 „PID2 Feedback Gain)

Parameter	Name	Range	Default
P10.33 (P11.33)	PID1 Feedback Gain (PID2 Feedback Gain)	-1000 % ... +1000 %	100.0 %

5 PID Controller

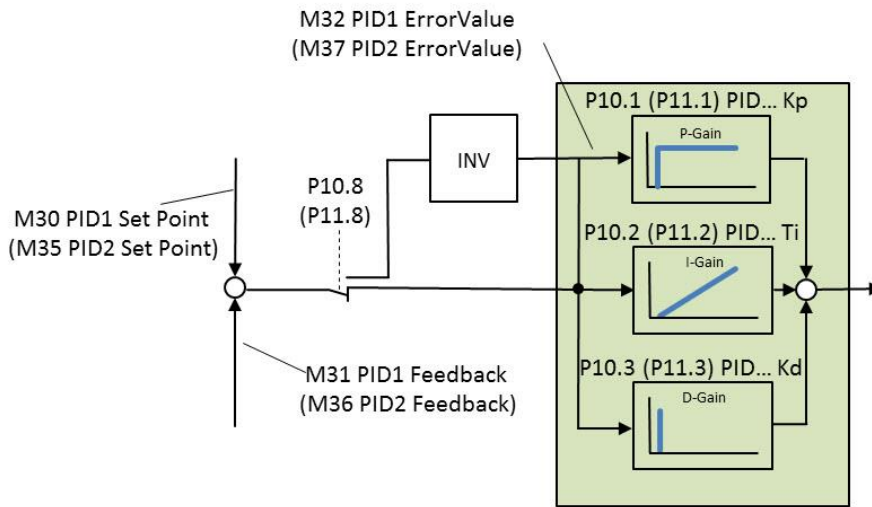

P- I- and D gains can be set separately.

P10.1 „PID1 Control Gain“

P11.1 „PID2 Control Gain“

Proportional gain

P10.2 „PID1 Control ITime“

P11.2 „PID2 Control ITime“

Integral time constant

P10.3 „PID1 Control DTime“

P11.3 „PID2 Control DTime“

Differential gain

Parameter	Name	Range	Default
P10.1 (P11.1)	PID1 Control Gain (PID2 Control Gain)	0 ... 200 %	100 %
P10.2 (P11.2)	PID1 Control ITime (PID2 Control ITime)	0 ... 600 s	1.00 s
P10.3 (P11.3)	PID1 Control DTime (PID2 Control DTime)	0 ... 100 %	0.00 %

5.1 Setting the control parameters

The response of the controller can be adopted to the controlled system by means of the parameters described in chapter 5. The setting has to be done as follows (parameter numbers refer to PID1).

- Set „PID1 Control Gain“ (P10.1) to 0 % and „PID1 Control ITime“ (P10.2) to 20 s.
- Start the variable frequency drive and verify if the required set point is reached quickly while maintaining stable operation of the system.
- If not, increase the PID Control Gain (P10.1) until the drive speed oscillates constantly. After this occurs, reduce the PID Control Gain (P10.1) slightly to reduce the oscillation.
- From there take the value found for PID Control Gain (P10.1) to 0.5 times that value and reduce the PID ITime (P10.2) until the feedback signal oscillates again.

- Increase the PID ITime (P10.2) until the oscillation stops. Take this value times 1.2 and use that value for PID ITime (P10.2).
- If signal noise is seen at high frequency, increase the filter time to filter the signal.
- If further tuning is required refer to the table below showing what is affected.

Measure	Rise Time	Overshoot	Settling Time	Steady State Error
Increase PID Control Gain	decreases	increases	not affected	decreases
Increase PID ITime	decreases	increases	increases	is eliminated
Increase PID DTime	not affected	decreases	decreases	not affected

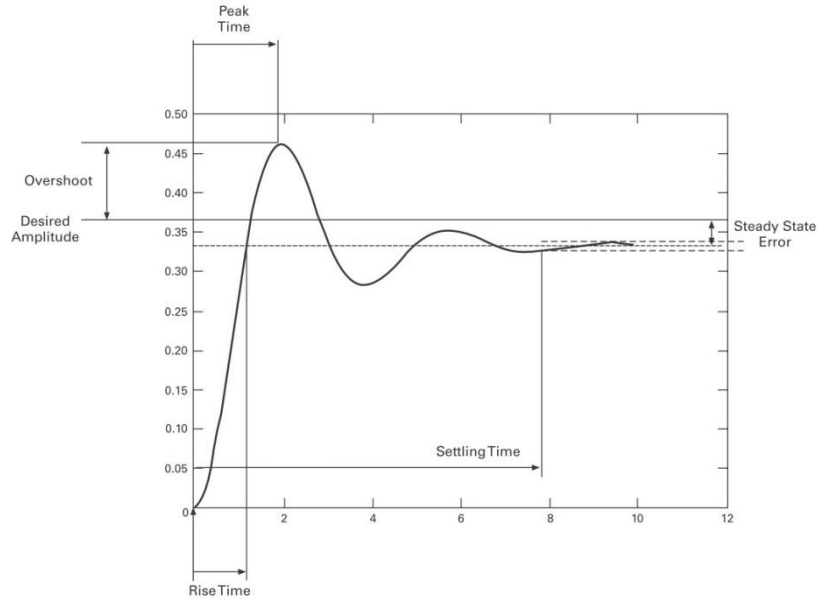

	Definition
Rise Time	The time required for the output to rise 90 % of the desired level for the first time
Overshoot	Difference between the peak level and the steady state level
Settling Time	Time required for the system to converge to its steady state
Steady State Error	Difference between the steady state level and the desired output level

5.2 Inverting the control deviation

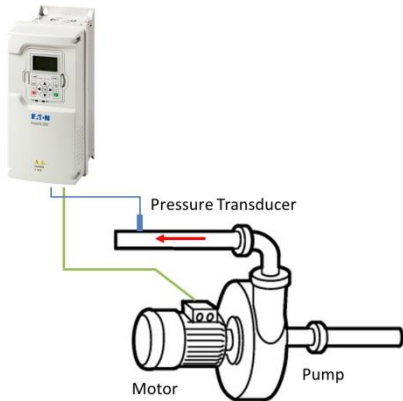

In the majority of cases an increase of the feedback value shall lead to a reduction of the PID controller’s output signal. If, for example, the pressure rises, the motor speed has to be reduced to keep the desired pressure → direct operation.

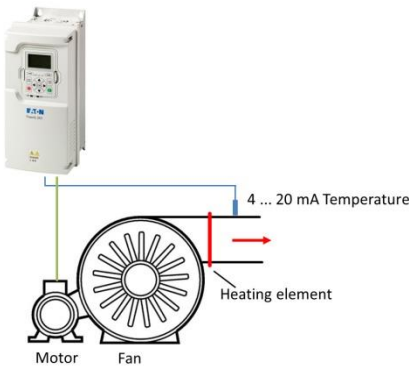

There are also applications, where an increase of the feedback signal shall lead to an increase of the PID controller’s output signal. One example is the control of the temperature, where the temperature is measured and where the variable frequency drive controls a fan motor. In case the temperature becomes too high, the fan motor has to run faster to prevent an over temperature → indirect operation.

The behavior of the controller is determined by the parameter P10.8 “PID1 Error Inversion” (P11.8 “PID2 Error Inversion”). See also block diagram in chapter 5.

- P10.8 (P11.8) = Not inverted (0) → An increase of the feedback value leads to a reduction of the motor speed.
- P10.8 (P11.8) = Inverted (1) → An increase of the feedback value leads to an increase of the motor speed.

Parameter	Name	Range	Default
P10.8 (P11.8)	PID1 Error Inversion (PID2 Error Inversion)	Not Inverted (0) Inverted (1)	0

5.3 Feedforward

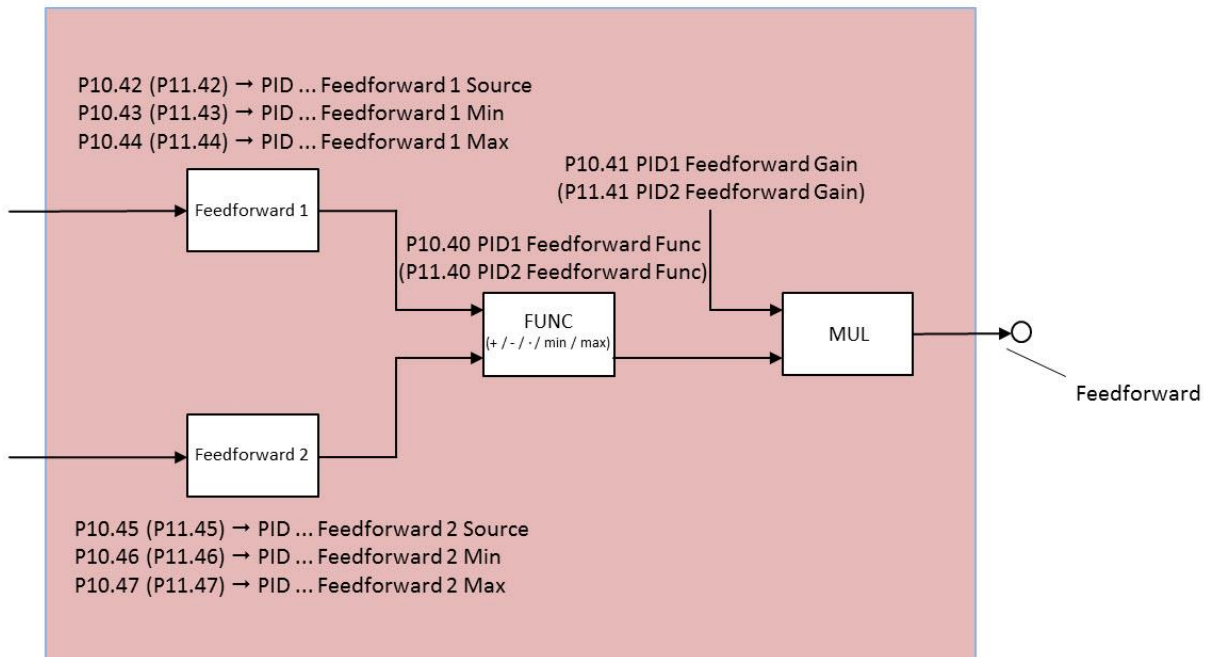

The feedforward signal is added to the output signal of the PID controller. The monitor value M33 “PID1 Output” (M38 “PID2 Output”) contains the addition of both values. See also block diagram in chapter 1. Feedforward is used to have shorter response times of the control. This is achieved by using the feedforward signal as speed reference for the motor. In this case the controller itself has only to deal with possible deviations between set point and feedback value and the gain can therefore be a higher one. It has to be noted, that the set point value for the PID controller is not necessarily proportional to the speed of the motor. An adaptation can be achieved by using the parameter P10.40 “PID1 Feedforward Func” (P11.40 “PID2 Feedforward Func”). It is possible to interconnect two signals (Feedforward 1 and Feedforward 2). The way of interconnection is described in chapter 5.3.2.

5.3.1 Selection of the feedforward source, upper and lower limits

The devices of the series DG1 have two feedforward channels (Feedforward 1 and Feedforward 2), which can be used separately or in combination. The way of interconnection is described in chapter 5.3.2.

Parameters P10.42 (P11.42) „PID ... Feedforward 1 Source“ and P10.45 (P11.45) „PID ... Feedforward 2 Source“ determine the way, how feedforward is applied. In addition a minimum and a maximum value of the feedback can be set for both channels separately.

P10.42 „PID1 Feedforward 1 Source“

P11.42 „PID2 Feedforward 1 Source“

This parameter determines the source of feedforward 1.

Not Used (0):	Feedforward channel 1 of the controller is not used.
AI1 (1)	The feedforward value 1 comes from analog input AI1.
AI2 (2):	The feedforward value 1 comes from analog input AI2.
Slot A: AI1 (3):	The feedforward value 1 comes from analog input AI1 on DXG-EXT-1AI2AO in Slot A.

Slot B: AI1 (4):	The feedforward value 1 comes from analog input AI1 on DXG-EXT-1AI2AO in Slot B.
FB Process Data Input 1 ... 8 (5-12)	The feedforward value 1 comes from fieldbus process data input 1...8.
PT100 Temperature (13)	The feedforward value 1 is the maximum temperature value among the connected PT100 sensors.
PID2 Output (14): PID1 Output (14):	The feedforward value 1 comes from the output of the controller PID2. The feedback value 1 comes from the output of the controller PID1.
SlotA PT100 Temp Channel 1...3 (15 ... 17)	The feedforward value 1 comes from PT100 Input 1...3 on DXG-EXT-THER1 in Slot A.
SlotB PT100 Temp Channel 1...3 (18 ... 20)	D The feedforward value 1 comes from PT100 Input 1...3 on DXG-EXT-THER1 in Slot B.

P10.43 „PID1 Feedforward 1 Min“

P11.43 „PID2 Feedforward 1 Min“

Minimum value of feedforward 1.

P10.44 „PID1 Feedforward 1 Max“

P11.44 „PID2 Feedforward 1 Max“

Maximum value of feedforward 1.

P10.45 „PID1 Feedforward 2 Source“

P11.45 „PID2 Feedforward 2 Source“

This parameter determines the source of feedforward 2.

Not Used (0):	Feedforward channel 2 of the controller is not used.
AI1 (1)	The feedforward value 2 comes from analog input AI1.
AI2 (2):	The feedforward value 2 comes from analog input AI2.
Slot A: AI1 (3):	The feedforward value 2 comes from analog input AI1 on DXG-EXT-1AI2AO in Slot A.
Slot B: AI1 (4):	The feedforward value 2 comes from analog input AI1 on DXG-EXT-1AI2AO in Slot B.
FB Process Data Input 1 ... 8 (5-12)	The feedforward value 2 comes from fieldbus process data input 1...8.
PT100 Temperature (13)	The feedforward value 2 is the maximum temperature value among the connected PT100 sensors.
PID2 Output (14): PID1 Output (14):	The feedforward value 2 comes from the output of the controller PID2. The feedback value 1 comes from the output of the controller PID1.
SlotA PT100 Temp Channel 1...3 (15 ... 17)	The feedforward value 2 comes from PT100 Input 1...3 on DXG-EXT-THER1 in Slot A.
SlotB PT100 Temp Channel 1...3 (18 ... 20)	D The feedforward value 2 comes from PT100 Input 1...3 on DXG-EXT-THER1 in Slot B.

P10.46 „PID1 Feedforward 2 Min“

P11.46 „PID2 Feedforward 2 Min“

Minimum value of feedforward 2.

P10.47 „PID1 Feedforward 2 Max“

P11.47 „PID2 Feedforward 2 Max“

Maximum value of feedforward 2.

Parameter	Name	Range	Default
P10.42 (P11.42)	PID1 Feedforward 1 Source (PID2 Feedforward 1 Source)	Not Used (0) AI1 (1) AI2 (2) Slot A: AI1 (3) AI1 on DXG-EXT-1AI2AO in Slot A Slot B: AI1 (4) AI1 on DXG-EXT-1AI2AO in Slot B FB Process Data Input 1 (5) FB Process Data Input 2 (6) FB Process Data Input 3 (7) FB Process Data Input 4 (8) FB Process Data Input 5 (9) FB Process Data Input 6 (10) FB Process Data Input 7 (11) FB Process Data Input 8 (12) PT100 Temperature (13) PID2 Output (14) at PID1 PID1 Output (14) at PID2 SlotA PT100 Temp Channel 1 (15) R1+/RM1/R1- on DXG-EXT-THER1 in Slot A SlotA PT100 Temp Channel 2 (16) R2+/RM2/R2- on DXG-EXT-THER1 in Slot A SlotA PT100 Temp Channel 3 (17) R3+/RM3/R3- on DXG-EXT-THER1 in Slot A SlotB PT100 Temp Channel 1 (18) R1+/RM1/R1- on DXG-EXT-THER1 in Slot B SlotB PT100 Temp Channel 2 (19) R2+/RM2/R2- on DXG-EXT-THER1 in Slot B SlotB PT100 Temp Channel 3 (20) R3+/RM3/R3- on DXG-EXT-THER1 in Slot B	0
P10.43 (P11.43)	PID1 Feedforward 1 Min (PID2 Feedforward 1 Min)	-200 % ... 200 %	0.00 %
P10.44 (P11.44)	PID1 Feedforward 1 Max (PID2 Feedforward 1 Max)	-200 % ... 200 %	100.00 %
P10.45 (P11.45)	PID1 Feedforward 2 Source (PID2 Feedforward 2 Source)	like P10.42 (like P11.42)	0
P10.46 (P11.46)	PID1 Feedforward 2 Min (PID2 Feedforward 2 Min)	-200 % ... 200 %	0.00 %
P10.47 (P11.47)	PID1 Feedforward 2 Max (PID2 Feedforward 2 Max)	-200 % ... 200 %	100.00 %

5.3.2 Interconnection of the feedforward signals

Parameter P10.40 "PID1 Feedforward Func" (P11.40 "PID2 Feedforward Func") determines, in which way the feedforward signal is applied to the controller. It has to be noted, that possibly a scaling with P10.41 (P11.41) is necessary.

Example: In case P10.40 = 4, the feedforward signals of source 1 and source 2 are added. When both signals have a value of 100 %, it would lead to 200 % as the result. To ensure comparability with the set point signal, the feedback signal has to be adopted with P10.41 = 50 %.

P10.40 „PID1 Feedforward Func“

P11.40 „PID2 Feedforward Func“

Source 1 (0)	The feedforward value is equivalent to the signal defined with P10.34 (P11.34).
SQRT(Source 1) (1)	The feedforward value is equivalent to the square root of source 1. Example: Source1 = 100 % Feedback value = $\sqrt{100} = 10$ %
SQRT(Source 1 – Source 2) (2)	The feedforward value is equivalent to the square root of (Source 1 – Source 2). Example: Source 1 = 100 %, Source 2 = 75 % Feedback value = $\sqrt{(100 - 75)} = \sqrt{25} = 5$ %
SQRT(Source 1) + SQRT(Source 2) (3)	The feedforward value is equivalent to the sum of the square roots of source 1 and source 2. Example: Source 1 = 100 %, Source 2 = 100 % Feedback value = $\sqrt{100} + \sqrt{100} = 10 + 10 = 20$ %
Source 1 + Source 2 (4)	The feedforward value is equivalent to the sum of Source 1 and Source 2. Example: Source 1 = 100 %, Source 2 = 100 % Feedback value = $100 + 100 = 200$ %
Source 1 – Source 2 (5)	The feedforward value is equivalent to the difference Source 1 – Source 2.
MIN(Source 1, Source 2) (6)	The feedforward value is equivalent to the smallest value out of Source 1 and Source 2. Example: Source 1 = 20 %, Source 2 = 50 % Feedback value = 20 %
MAX(Source 1, Source 2) (7)	The feedforward value is equivalent to the biggest value out of Source 1 and Source 2. Example: Source 1 = 20 %, Source 2 = 50 % Feedback value = 50 %
MEAN(Source 1, Source 2) (8)	The feedforward value is equivalent to the mean value out of Source 1 and Source 2. Example: Source 1 = 30 %, Source 2 = 60 % Feedback value = $(30 + 60)/2 = 45$ %

Parameter	Name	Range	Default
P10.40 (P11.40)	PID1 Feedforward Func (PID2 Feedforward Func)	Source 1 (0) SQRT(Source 1) (1) SQRT(Source 1 – Source 2) (2) SQRT(Source 1) + SQRT (Source 2) (3) Source 1 + Source 2 (4) Source 1 – Source 2 (5) MIN(Source 1, Source 2) (6) MAX(Source 1, Source 2) (7) MEAN (Source 1, Source 2) (8)	0

5.3.3 Scaling the feedforward signal

It is possible to adopt the feedback value by using a multiplier. See also block diagram in chapter 5.3.

P10.41 „PID1 Feedforward Gain“ (P11.41 „PID2 Feedforward Gain“)

Parameter	Name	Range	Default
P10.41 (P11.41)	PID1 Feedforward Gain (PID2 Feedforward Gain)	-1000 % ... +1000 %	100.0 %

5.4 Dead band

In case the error value is inside a range, defined with P10.9 „PID1 Dead Band“ resp. P11.9 „PID2 Dead Band“, the actual value of the PID controller output (M33 M38) will be frozen and doesn't change as long as the error value is inside the band. This prevents oscillations inside the system at small error values. These deviations between set point and feedback value are negligible in systems with flow control (pumps, fans) and the entire system operates more reliably.

P10.09 „PID1 Dead Band“

P11.09 „PID2 Dead Band“

Error value, defined in process units (see chapter 6), below which the PID controller's output value is frozen to prevent oscillations inside the system.

P10.10 „PID1 Dead Band Delay“

P11.10 „PID2 Dead Band Delay“

In case the error value is higher than the defined dead band the time set with P10.10 (P11.10) has to expire, before the controller is active again.

Parameter	Name	Range	Default
P10.9 (P11.9)	PID1 Dead Band (PID2 Dead Band)	Depending on the process unit, set with parameters P10.4 (P11.4) and P10.7 (P11.7), see chapter 6	0
P10.10 (P11.10)	PID1 Dead Band Delay (PID2 Dead Band Delay)	0 ... 320 s	0.00 s

5.5 Sleep mode

In some applications it is not necessary to run the motor permanently. The devices of the series DG1 have the possibility to force the output of the PID controller to zero and reactivate it in case it is necessary → Sleep mode. By default, sleep mode is not activated. The settings can be done separately for the set point values “PID Set Point 1” and “PID Set Point 2”. The actual settings depend on the set point, which is active at the time (see 3.1).

5.5.1 Settings when using „PID Set Point 1“

P10.17 „PID1 Set Point 1 Sleep Enable“

P11.17 „PID2 Set Point 1 Sleep Enable“

Enabling of the sleep mode.

Disabled (0): The PID controller is always active.

Enabled (1): In case the two conditions below are fulfilled, the PID controller's output will be set to zero respectively reactivated.

P10.18 „PID1 Set Point 1 Sleep Unit Sel“

P11.18 „PID2 Set Point 1 Sleep Unit Sel“

The PID controller enters the sleep mode, when a threshold defined with P10.19 (P11.19) is undercut for a certain time. With this parameter one can determine, what is used as reference. Example: When “Output Frequency (0)” is selected, the output frequency of the variable frequency drive must be below the threshold, before the drive changes into sleep mode.

- Output Frequency (0)
- Motor Speed (1)
- Motor Current (2)
- PID1 Feedback (3) resp. PID2 Feedback (3)

P10.19 „PID1 Set Point 1 Sleep Level“

P11.19 „PID2 Set Point 1 Sleep Level“

Determination of the threshold, which must be undercut for the time defined with P10.20 (P11.20), before the PID controller changes to sleep mode.

Selection with P10.18 (P11.18)	Threshold (P10.19) (P11.19) defined in
Output Frequency (0)	Hz
Motor Speed (1)	min ⁻¹
Motor Current (2)	A
PID... Feedback (3)	process unit, set with parameters P10.4 (P11.4) and P10.7 (P11.7), see chapter 6

P10.20 „PID1 Set Point 1 Sleep Delay“

P11.20 „PID2 Set Point 1 Sleep Delay“

Time, for which the threshold set with P10.19 (P11.10) must be undercut, before the PID controller enters the sleep mode.

P10.21 „PID1 Set Point 1 Wake Up Level“

P11.21 „PID2 Set Point 1 Wake Up Level“

Setting of a threshold, at which the PID controller is reactivated again. The conditions for leaving the sleep mode depend on the setting of P10.52 “PID1 Wake Up Action” (P11.52 PID2 Wake Up Action).

Selection with P10.52 (P11.52)	Threshold defined in
Below Wake Up Level (0)	process unit, set with parameters P10.4 (P11.4) and P10.7 (P11.7), see chapter 6
Above Wake Up Level (1)	
Below Wake Up Level(PID ref.) (2)	% deviation from set point
Above Wake Up Level(PID ref.) (3)	

P10.52 „PID1 Wake Up Action“

P11.52 „PID2 Wake Up Action“

The setting of this parameter is valid for “PID Set Point 1” as well as for “PID Set Point 2”. It determines, if the PID controller leaves the sleep mode, when the feedback value is higher or lower than the Wake Up Level (P10.21, P11.21).

- Below Wake Up Level (0): The PID controller is reactivated, when the feedback value is below the threshold defined with P10.21 (P11.21).
- Above Wake Up Level (1): The PID controller is reactivated, when the feedback value is above the threshold defined with P10.21 (P11.21).
- Below Wake Up Level(PID ref.) (2): The threshold is not a fixed value, but a percentage of the set point value at the time. When the feedback value is below this threshold, the PID controller is reactivated.
- Above Wake Up Level(PID ref.) (3): The threshold is not a fixed value, but a percentage of the set point value at the time. When the feedback value is above this threshold, the PID controller is reactivated.

5.5.2 Settings when using „PID Set Point 2“

P10.26 „PID1 Set Point 2 Sleep Enable“

P11.26 „PID2 Set Point 2 Sleep Enable“

Enabling of the sleep mode.

Disabled (0): The PID controller is always active.

Enabled (1): In case the two conditions below are fulfilled, the PID controller’s output will be set to zero respectively reactivated.

P10.27 „PID1 Set Point 2 Sleep Unit Sel“

P11.127 „PID2 Set Point 2 Sleep Unit Sel“

The PID controller enters the sleep mode, when a threshold defined with P10.28 (P11.28) is undercut for a certain time. With this parameter one can determine, what is used as reference. Example: When “Output Frequency (0)” is selected, the output frequency of the variable frequency drive must be below the threshold, before the drive changes into sleep mode.

- Output Frequency (0)
- Motor Speed (1)
- Motor Current (2)
- PID1 Feedback (3) resp. PID2 Feedback (3)

P10.28 „PID1 Set Point 2 Sleep Level“

P11.28 „PID2 Set Point 2 Sleep Level“

Determination of the threshold, which must be undercut for the time defined with P10.20 (P11.20), before the PID controller changes to sleep mode.

Selection with P10.27 (P11.27)	Threshold (P10.28) (P11.28) defined in
Output Frequency (0)	Hz
Motor Speed (1)	min ⁻¹
Motor Current (2)	A
PID... Feedback (3)	process unit, set with parameters P10.4 (P11.4) and P10.7 (P11.7), see chapter 6

P10.29 „PID1 Set Point 2 Sleep Delay“

P11.29 „PID2 Set Point 2 Sleep Delay“

Time, for which the threshold set with P10.28 (P11.28) must be undercut, before the PID controller enters the sleep mode.

P10.30 „PID1 Set Point 2 Wake Up Level“

P11.30 „PID2 Set Point 2 Wake Up Level“

Setting of a threshold, at which the PID controller is reactivated again. The conditions for leaving the sleep mode depend on the setting of P10.52 “PID1 Wake Up Action” (P11.52 PID2 Wake Up Action).

Selection with P10.52 (P11.52)	Threshold defined in
Below Wake Up Level (0)	process unit, set with parameters P10.4 (P11.4) and P10.7 (P11.7), see chapter 6
Above Wake Up Level (1)	
Below Wake Up Level(PID ref.) (2)	% deviation from set point
Above Wake Up Level(PID ref.) (3)	

P10.52 „PID1 Wake Up Action“

P11.52 „PID2 Wake Up Action“

The setting of this parameter is valid for “PID Set Point 1” as well as for “PID Set Point 2”. It determines, if the PID controller leaves the sleep mode, when the feedback value is higher or lower than the Wake Up Level (P10.21, P11.21).

- Below Wake Up Level (0): The PID controller is reactivated, when the feedback value is below the threshold defined with P10.21 (P11.21).
- Above Wake Up Level (1): The PID controller is reactivated, when the feedback value is above the threshold defined with P10.21 (P11.21).
- Below Wake Up Level(PID ref.) (2): The threshold is not a fixed value, but a percentage of the set point value at the time. When the feedback value is below this threshold, the PID controller is reactivated.
- Above Wake Up Level(PID ref.) (3): The threshold is not a fixed value, but a percentage of the set point value at the time. When the feedback value is above this threshold, the PID controller is reactivated.

5.5.3 General procedure. Example for PID1 Set Point 1

- The controller PID1 operates in its normal working mode . Set Point is PID1 Set Point 1.
- When the unit selected with P10.18 is below the threshold (P10.19) for a time longer than defined with P10.20, the PID controller enters the sleep mode.
- The PID controller remains in sleep mode until the conditions, defined with P10.21 and P10.52, are fulfilled and changes to normal operation afterwards.

5.5.4 Parameters used in sleep mode

Parameter	Name	Range	Default
P10.17 (P11.17)	PID1 Set Point 1 Sleep Enable (PID2 Set Point 1 Sleep Enable)	Disabled (0) Enabled (1)	0
P10.18 (P11.18)	PID1 Set Point 1 Sleep Unit Sel (PID2 Set Point 1 Sleep Unit Sel)	Output Frequency (0) Motor Speed (1) Motor Current (2) PID1 (PID2) Feedback (3)	0
P10.19 (P11.19)	PID1 Set Point 1 Sleep Level (PID2 Set Point 1 Sleep Level)	Depending on the setting of P10.18 (P11.18)	0
P10.20 (P11.20)	PID1 Set Point 1 Sleep Delay (PID2 Set Point 1 Sleep Delay)	0 ... 3000 s	0
P10.21 (P11.21)	PID1 Set Point 1 Wake Up Level (PID2 Set Point 1 Wake Up Level)	Depending on the setting of P10.18 (P11.18)	0
P10.26 (P11.26)	PID1 Set Point 2 Sleep Enable (PID2 Set Point 2 Sleep Enable)	Disabled (0) Enabled (1)	0
P10.27 (P11.27)	PID1 Set Point 2 Sleep Unit Sel (PID2 Set Point 2 Sleep Unit Sel)	Output Frequency (0) Motor Speed (1) Motor Current (2) PID1 (PID2) Feedback (3)	0
P10.28 (P11.28)	PID1 Set Point 2 Sleep Level (PID2 Set Point 2 Sleep Level)	Depending on the setting of P10.27 (P11.27)	0
P10.29 (P11.29)	PID1 Set Point 2 Sleep Delay (PID2 Set Point 2 Sleep Delay)	0 ... 3000 s	0
P10.30 (P11.30)	PID1 Set Point 2 Wake Up Level (PID2 Set Point 2 Wake Up Level)	Depending on the setting of P10.27 (P11.27)	0
P10.52 (P11.52)	PID1 Wake Up Action (PID2 Wake Up Action)	Below Wake Up Level (0) Above Wake Up Level (1) Below Wake Up Level(PID ref.) (2) Above Wake Up Level(PID ref.) (3)	0

6 Process units

By default the settings and display values of set point and feedback are shown in percent. There is also the possibility to use process units like bar, l/min, °C

P10.4 „PID1 Process Unit“

P11.4 „PID2 Process Unit“

Selection of the process unit. In pump applications it could be for example the pressure in bar →

P10.4 = „bar (16)“

P10.5 „PID1 Process Unit Min“

P11.5 „PID2 Process Unit Min“

This parameter determines the value, which is displayed at 0 % feedback (example see further below).

P10.6 „PID1 Process Unit Max“

P11.6 „PID2 Process Unit Max“

This parameter determines the value, which is displayed at 100 % feedback (example see further below).

P10.7 „PID1 Process Unit Decimal“

P11.7 „PID2 Process Unit Decimal“

Number of places behind the decimal point. Example:

Required display value 24.0 → P10.7 = 1

24.00 → P10.7 = 2

Parameter	Name	Range	Default
P10.4 (P11.4)	PID1 Process Unit (PID2 Process Unit)	% (0) 1/min (1) rpm (2) ppm (3) pps (4) l/s (5) l/min (6) l/h (7) kg/s (8) kg/min (9) kg/h (10) m ³ /s (11) m ³ /min (12) m ³ /h (13) m/s (14) mbar (15) bar (16) pa (17) kPa (18) mVS (19) kW (20) °C (21) GPM (22) gal/s (23) gal/min (24) gal/h (25)	% (0)

Parameter	Name	Range	Default
		lb/s (26) lb/min (27) lb/h (28) CFM (29) ft3/s (30) ft3/min (31) ft3/h (32) ft/s (33) in wg (34) ft wg (35) PSI (36) lb/in2 (37) HP (38) °F (39) pa (40) WC (41) HG (42) ft (43) m (44)	
P10.5 (P11.5)	PID1 Process Unit Min (PID2 Process Unit Min)	-99999 ... 100	0
P10.6 (P11.6)	PID1 Process Unit Max (PID2 Process Unit Max)	0 - 99999	100.00
P10.7 (P11.7)	PID1 Process Unit Decimal (PID2 Process Unit Decimal)	0 ... 4	2

6.1 Configuration example for controller PID1:

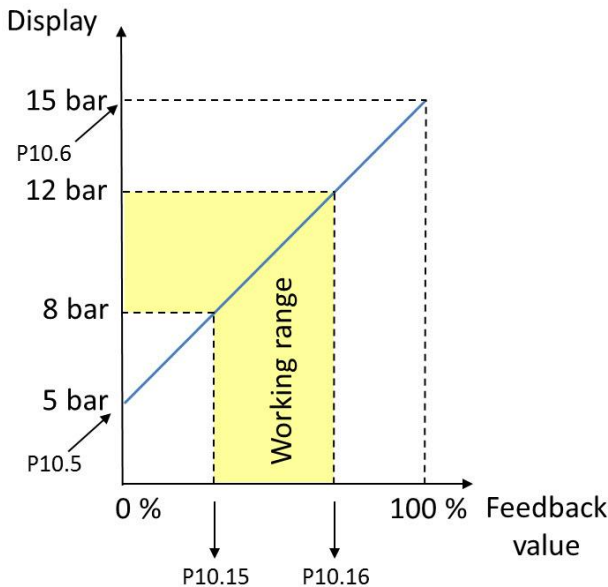

The display values for a pressure control should appear in bar with one decimal place. A feedback sensor with 0 ... 10 V output signal is used. 0 V correspond to a pressure of 5.0 bar, 10 V correspond to 15.0 bar. The pressure shall be controlled inside a range from 8 to 12 bar.

Configuration of the display:

- Selection of the process unit: P10.4 = bar(16)
- Decimal places: P10.7 = 1
- Display at 0 % feedback: P10.5 = 5.0
- Display @ 100 % feedback: P10.6 = 15.0

Minimum and maximum set point value:

Working range: 100 % = 15.0 bar – 5.0 bar = 10.0 bar

Minimum set point: P10.15 = 30 % (8 bar – 5 bar = 3 bar = 30 % of 10 bar)

Maximum set point: P10.16 = 70 % (12 bar – 5 bar = 7 bar = 70 % of 10 bar)

In case the set point value is provided by a potentiometer, it would correspond to 8 bar at full ccw and 12 bar at full cw.

7 Signaling

7.1 Exceeding the error value

It is possible to monitor the deviation between set point and feedback value and to generate a signal, when the deviation is out of range for a certain time. The signal can be assigned to a digital output, a relay output or a virtual output (DO = active resp. the relay contact closes). The signal is not active in case the PID controller is disabled.

P5.1 ... P5.6 (digital outputs)

Selection of the digital output the monitor signal is assigned to. "PID1 Superv (11)" has to be selected for PID controller PID1, "PID2 Superv (12)" for PID2.

P5.24 „PID1 Superv Enable“

P5.28 „PID2 Superv Enable“

Enabling of the supervision

Disabled (0) → No signaling in case of deviation

Enabled (1) → When the deviation is higher than defined with P5.25 and P5.26 resp. P5.29 and P5.30 for a time defined with P5.27 resp. P5.31, the relay contact closes respectively the digital output has HIGH signal. In case the feedback value is out of the defined range, a counter starts, whose content initiates the signaling. When the feedback value enters the tolerance band again before a signal has been generated, the counter counts down.

P5.25 „PID1 Superv Upper Limit“

P5.29 „PID2 Superv Upper Limit“

Upper limit of the tolerance band

P5.26 „PID1 Superv Lower Limit“

P5.30 „PID2 Superv Lower Limit“

Lower limit of the tolerance band

P5.27 „PID1 Superv Delay“

P5.31 „PID2 Superv Delay“

Time, for which the feedback value must be outside the band, defined with P5.25 and P5.26 resp. P5.29 and P5.30, before a signal is generated.

Parameter	Name	Range	Default
P5.1 or P5.2 or P5.3 or P5.4 or P5.5 or P5.6	DO1 Function RO1 Function RO2 Function RO3 Function Virtual RO1 Function Virtual RO2 Function	Not Used (0) ... PID1 Superv (11) PID2 Superv (12) ... Run Bypass/Drive (60)	
P5.24 (P5.28)	PID1 Superv Enable (PID2 Superv Enable)	Disabled (0) Enabled (1)	0
P5.25 (P5.29)	PID1 Superv Upper Limit (PID2 Superv Upper Limit)	Depending on the process unit, set with parameters P10.4 (P11.4) and P10.7 (P11.7), see chapter 6	0
P5.26 (P5.30)	PID1 Superv Lower Limit (PID2 Superv Lower Limit)		0
P5.27 (P5.31)	PID1 Superv Delay (PID2 Superv Delay)	0 ... 3000 s	0 s

7.2 Feedback loss

This function is used to define the behavior of the drive in case the feedback signal at the analog input is lost.

P9.51 „PID Feedback AI Loss Response“

- P9.51 = „No Action (0)“
 - A loss of the feedback signal will be ignored.
- P9.51 = „Warning (1)“
 - In case of feedback loss a warning signal is generated.
 - A relay contact closes, when it is configured accordingly (“Warning (5)”).
- P9.51 = „Fault (2)“
 - In case of feedback loss a fault signal is generated.
 - The variable frequency drive will be disabled.
 - The drive tries to restart according to the setting of P9.55.
 - After the last useless restart a relay contact closes, when it is configured for “Fault (3)” respectively opens, when it is configured for “Fault Invert (4)”
- P9.51 = „Warning: Preset Freq. (3)“
 - In case of feedback loss a warning signal is generated.
 - A relay contact closes, when it is configured accordingly (“Warning (5)”).
 - The drive ramps to the frequency defined with P9.52 “PID Feedback AI Loss Pre Freq”.
 - After the time, defined with P9.54 “PID Feedback AI Loss PreFreq Timeout”, the drive trips and generates a fault signal.

P9.52 „PID Feedback AI Loss Pre Freq“

Defines the output frequency of the drive after a feedback loss, when P9.51 = 3.

P9.54 „PID Feedback AI Loss PreFreq Timeout“

When P9.51 = 3 the drive runs with the frequency defined with P9.52 for the time defined here. After expiration of the time, the drive trips. The setting “P9.54 = 0” disables the timer function.

P9.55 „PID Feedback AI Loss Attempts“

Maximum number of starting attempts after a fault when P9.51 = “Fault (2)”.

Parameter	Name	Range	Default
P9.51	PID Feedback AI Loss Response	- No Action (0) - Warning (1) - Fault (2) - Warning: Preset Freq. (3)	No Action (0)
P9.52	PID Feedback AI Loss Pre Freq	0.00 ... 400.00 Hz	0.00 Hz
P9.54	PID Feedback AI Loss PreFreq Timeout	0 ... 6000 s	0 s
P9.55	PID Feedback AI Loss Attempts	0 ... 10	1