

Data Sheet | Item Number: 771-5001/160-000

pre-assembled connecting cable; Eca; Plug/open-ended; 5-pole; Cod. I; H05Z1Z1-F
3G 1.5 mm²; 5 m; 1,50 mm²; blue

<https://www.wago.com/771-5001/160-000>

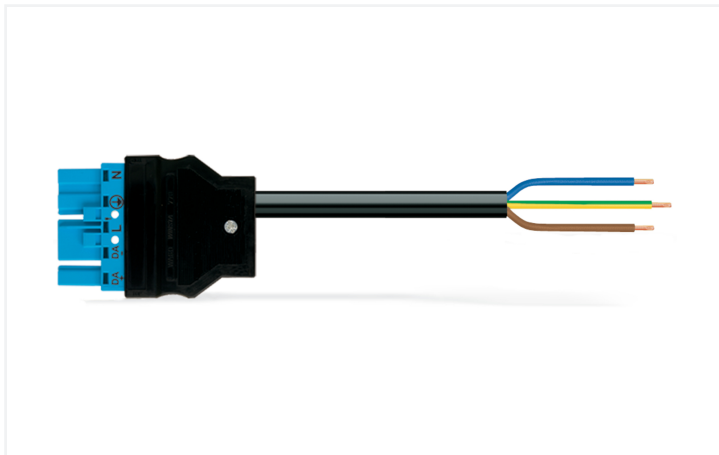

Color: ■ blue

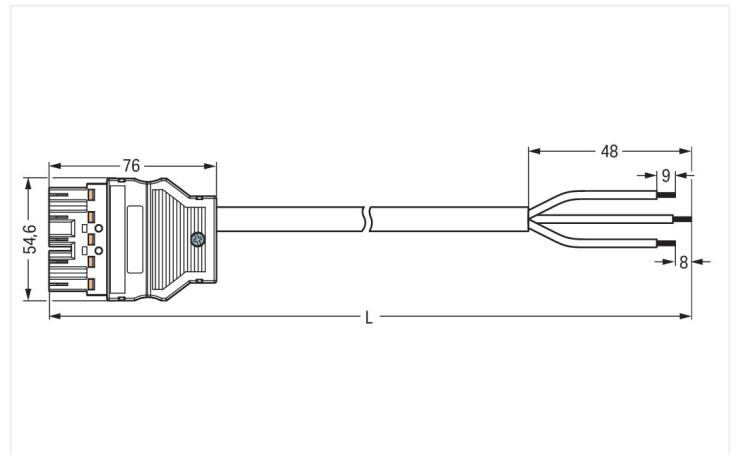

Dimensions in mm

Cable assembly WINSTA® MIDI with protection against mismatching

The WINSTA® MIDI cable assembly with protection type IP20 supports fast, reliable installation. WAGO pluggable installation connectors are useful when requirements repeat or are planned on a specified pattern, for example for installing grid lighting or flush-mount lighting. For greater security in electrical installations, the pluggable installation connector is provided with mechanical protection against mismatching. The pluggable installation connector offers protection against contact with live components in accordance with protection type IP20 (When mated: IP2xC (These compact connectors are not designed for use in open, easily accessible areas!)). Controlled lighting, as used with the DALI standard, for example, is the primary domain of use of WINSTA® MIDI pluggable installation connectors with I coding. The WINSTA® MIDI Pluggable Connection System with Push-in CAGE CLAMP® spring pressure connection technology facilitates precise electrification. Thanks to the built-in test slot, connections can be checked even when they are plugged in. That saves time and reduces installation labor and costs. According to the European CPR, the fire class of the cables used in construction is decisive for the safety of buildings, too. For buildings with medium-level safety requirements, cable assemblies with fire class E are suitable. In the production of this cable assembly, we eliminated the use of halogen. That is an important contribution to environmental protection.

Fast, secure pluggable connections – cable assemblies from WAGO

The cable assembly is equipped with a plug and a free end. The WINSTA® Pluggable Connection System allows pluggable electrical installation. This saves time, lowers costs, and reduces the need for servicing. Now you can also reduce installation costs without compromising safety and quality: with protection type IP20 reduces the need for servicing and prevents unnecessary downtime.

- pluggable installation connectors with protection against mismatching
- pre-assembled versions
- for intelligent, easy lighting installation
- ready to install and use immediately
- convenient installation and commissioning

Notes

Note

Cables with a different fire class can be found in the eShop.

Electrical data

Ratings per	IEC/EN 60664-1		
Overvoltage category	III	III	II
Pollution degree	3	2	2
Nominal voltage	250 V	-	-
Rated impulse withstand voltage	4 kV	-	-
Rated current	16 A	-	-

General information

Note on contact resistance	approx. 1 mΩ of contact resistance approx. 0.25 mΩ contact transition plug/ socket
----------------------------	--

Connection Data

Total number of potentials	3
PE function	Preceding PE contact
Conductor preparation	ultrasonically tip-bonded

Connection 1

Strip length	9 mm / 0.35 inches
Pole number	5
Wire cross-section	1.5 mm ²
Strip length (outer insulation)	48 mm
Connection type	Plug - free end

Physical data

Pin spacing	10 mm / 0.394 inches
Width	54.6 mm / 2.15 inches
Height	17 mm / 0.669 inches
Total length	5 m

Mechanical data

Use	DALI, Lighting Management
Coding	I
Variable coding	No
Marking	N ⊕ L DA- DA+
Mating force of a plug-in connection	approx. 20 ... 70 N (depending on pole number)
Retention force of a plug-in connection	when locked: > 80N
Unmating force of a plug-in connection	when unlocked: approx. 20 ... 70 N (depending on pole number)
Number of mating cycles	200, without resistive load
Connection type	Plug - free end
Type of pre-assembled cable	Connecting cable
Cable type	H05Z1Z1-F 3G1.5
Protection type	IP20; When mated: IP2xC (These compact connectors are not designed for use in open, easily accessible areas!)

Plug-in connection

Mismating protection	Yes
Note on mismating protection	All WINSTA® components are 100% protected against mismating when: a.) plugging different numbers of poles b.) plugging while rotated 180 c.) plugging while laterally staggered d.) plugging one pole
Locking lever	Can be retrofitted
Locking of plug-in connection	Locking lever
Note on locking system	All connectors for mounted installations (snap-in versions for lighting fixtures or devices, all types of PCB and distribution connectors) are factory-equipped with locking levers to ensure plugs and sockets are securely locked. Additional locking levers are only required for flying leads (plug/socket).

Material data

Note (material data)	Information on material specifications can be found here
Color	blue
Insulation material (main housing)	Polyamide (PA66)
Flammability class per UL94	V0
Fire class per EN 50575	E _{ca}
Contact material	Copper or copper alloy; surface-treated
Contact Plating	Tin
Fire load	150.308 MJ
Connector color	blue
Strain relief color	black
Sheathed cable color	black
Printing color of sheathed cable	white
Halogen-free	Yes
Silicon-free	Yes
Sheath material	Halogen-free
Rubber cable	No
Weight	515.9 g
Copper weight of the raw cable	0.043 kg/m

Environmental requirements

Processing temperature	-5 ... +40 °C
Continuous operating temperature	-35 ... +85 °C
Note on continuous operating temperature	Cable for temperatures ≤ 70 °C (including halogen-free) Insulating parts for temperatures ≤ 105 °C

Commercial data

PU (SPU)	1 pcs
Packaging type	unpacked
Country of origin	DE
GTIN	4055143261401
Customs tariff number	85444290900

Product Classification

UNSPSC	26121629
eCl@ss 10.0	27-44-06-04
eCl@ss 9.0	27-44-06-04
ETIM 9.0	EC002587
ETIM 10.0	EC002587
ECCN	NO US CLASSIFICATION

Environmental Product Compliance

RoHS Compliance Status	Compliant, No Exemption
------------------------	-------------------------

Downloads

Environmental Product Compliance

Compliance Search

Environmental Product Compliance
771-5001/160-000



Documentation

Bid Text

771-5001/160-000	19.02.2019	xml 3.05 KB	
771-5001/160-000	09.02.2015	doc 25.50 KB	

1 Compatible Products

1.1 Required Accessories

1.1.1 Locking system

1.1.1.1 Locking system



Item No.: 770-101

Locking lever; for flying leads; for manual operation; black

Item No.: 770-121

Locking lever; for flying leads; for manual operation; white

Item No.: 770-111

Locking lever; for flying leads; for tool operation; black

Item No.: 770-131

Locking lever; for flying leads; for tool operation; white

1.2 Optional Accessories

1.2.1 Cover

1.2.1.1 Cover



Item No.: 770-360

Lockout cap; for plugs; 5-pole; separable; yellow

1.2.2 Installation

1.2.2.1 Mounting accessories



Item No.: 770-310

Mounting carrier; 2- to 5-pole; for flying leads; black

1.2.3 Marking

1.2.3.1 Marker



Item No.: 770-450/000-006
Marker card; Plastic; blue



Item No.: 770-450/000-001
Marker card; Plastic; green



Item No.: 770-450/000-012
Marker card; Plastic; orange



Item No.: 770-450/000-005
Marker card; Plastic; red



Item No.: 770-450
Marker card; Plastic; white



Item No.: 770-450/000-002
Marker card; Plastic; yellow

1.2.3.2 Marking strip



Item No.: 210-334
Marking strips; as a DIN A4 sheet; Strip width 5 mm; Strip length 182 mm; plain; Self-adhesive; white



Item No.: 210-333
Marking strips; as a DIN A4 sheet; Strip width 6 mm; Strip length 182 mm; plain; Self-adhesive; white