

Data Sheet | Item Number: 771-8965/007-201

pre-assembled interconnecting cable; Eca; Distribution connector with phase selection/plug; 5-pole; Cod. A; H05VV-F 5G 2.5 mm²; 2 m; 2,50 mm²; black

<https://www.wago.com/771-8965/007-201>



Color: ■ black

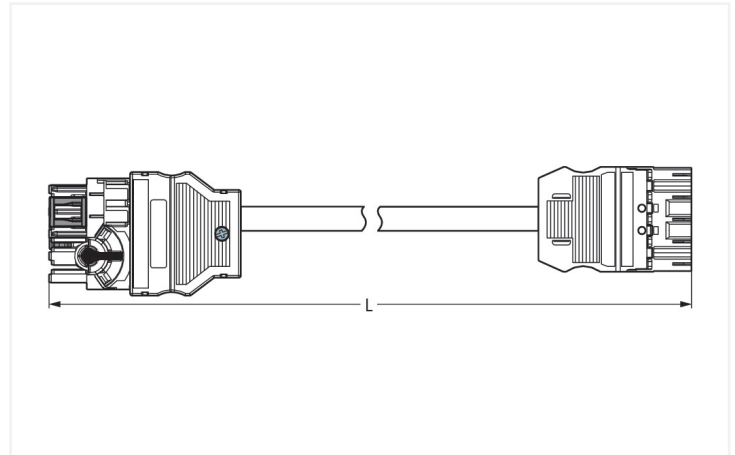

Dimensions in mm

Cable assembly WINSTA® MIDI with protection type IP20

The WINSTA® MIDI cable assembly A coding is the pluggable solution for your use in control cabinets, for lighting connections or on PCBs. The pluggable installation connectors with spring pressure connection technology work without screw connections. They allow flexible, error-free installation in numerous possible uses. For greater protection in electrical installations, the pluggable installation connector is equipped with mechanical protection against mismatching. The pluggable installation connector is protected against ingress by solid objects in accordance with protection type IP20 (When mated: IP2xC (These compact connectors are not designed for use in open, easily accessible areas!)). Standard mains applications for almost any domain of use can be realised with WINSTA® MIDI pluggable installation connectors with A coding. The rated current and voltage are important criteria for selecting a pluggable installation connector: They provide information about possible domains of use and applications. This product has a current rating of 20 A – as a result it is also suitable for high power loads. The WINSTA® MIDI product line allows maximum flexibility for the electrical installation. With its Push-in CAGE CLAMP® spring pressure connection technology, it ensures error-free, time-saving installation and offers flexibility and customization for meeting all installation requirements. According to the European CPR, the fire class of the cables used for construction is critical for building safety, too. For buildings with average safety requirements, cable assemblies with fire class E are suitable.

Fast, secure pluggable connections – cable assemblies from WAGO

A distribution connector with phase selection and a plug are provided. The WINSTA® Pluggable Connection System is perfectly tailored to the very strict requirements of building installation. It makes electrical installation pluggable, and consequently faster, more reliable, and error-free. Using this pre-assembled system decreases time spent on assembly and errors during installation at the construction site. Now you can also reduce installation costs without compromising quality and safety: with protection type IP20 eliminates the need for servicing and prevents unnecessary downtime.

- effective protection against mismatching
- pre-assembled versions
- with A coding for a great number of applications
- ready to install and use immediately
- convenient installation and commissioning

Notes

Note Cables with a different fire class can be found in the eShop.

Electrical data

Ratings per	IEC/EN 60664-1			General information	
Overvoltage category	III	III	II	Note on contact resistance	approx. 1 mΩ of contact resistance approx. 0.25 mΩ contact transition plug/ socket
Pollution degree	3	2	2		
Nominal voltage	400 V	-	-		
Rated impulse withstand voltage	6 kV	-	-		
Rated current	20 A	-	-		

Connection Data

Total number of potentials	5	Connection 1	
		Pole number	5
		Wire cross-section	2.5 mm ²
		Connection type	Distribution connector with phase selection - Plug

Connection 2

Pole number 3

Physical data

Pin spacing	10 mm / 0.394 inches
Width	54.6 mm / 2.15 inches
Height	43.8 mm / 1.724 inches
Total length	2 m

Mechanical data

Use	General mains applications
Coding	A
Variable coding	Yes
Marking	N ⊕ L1 L2 L3
Potential marking	N ⊕ L1 L2 L3
Mating force of a plug-in connection	approx. 20 ... 70 N (depending on pole number)
Retention force of a plug-in connection	when locked: > 80N
Unmating force of a plug-in connection	when unlocked: approx. 20 ... 70 N (depending on pole number)
Number of mating cycles	200, without resistive load
Connection type	Distribution connector with phase selection - Plug
Type of pre-assembled cable	Interconnecting cable
Cable type	H05VV-F 5G2.5
Protection type	IP20; When mated: IP2xC (These compact connectors are not designed for use in open, easily accessible areas!)

Plug-in connection

Mismating protection	Yes
Note on mismating protection	All WINSTA® components are 100% protected against mismating when: a.) plugging different numbers of poles b.) plugging while rotated 180 c.) plugging while laterally staggered d.) plugging one pole
Locking lever	Can be retrofitted
Locking of plug-in connection	Locking lever
Note on locking system	All connectors for mounted installations (snap-in versions for lighting fixtures or devices, all types of PCB and distribution connectors) are factory-equipped with locking levers to ensure plugs and sockets are securely locked. Additional locking levers are only required for flying leads (plug/socket).

Material data

Note (material data)	Information on material specifications can be found here
Color	black
Insulation material (main housing)	Polyamide (PA66)
Fire class per EN 50575	E _{ca}
Contact material	Copper or copper alloy; surface-treated
Contact Plating	Tin
Fire load	61.587 MJ
Connector color	black
Strain relief color	black
Sheathed cable color	black
Printing color of sheathed cable	white
Halogen-free	No
Silicon-free	Yes
Sheath material	PVC
Rubber cable	No
Weight	525 g

Environmental requirements

Processing temperature	-5 ... +40 °C
Continuous operating temperature	-35 ... +85 °C
Note on continuous operating temperature	Cable for temperatures ≤ 70 °C (including halogen-free) Insulating parts for temperatures ≤ 105 °C

Commercial data



PU (SPU)	1 pcs
Packaging type	unpacked
Country of origin	DE
GTIN	4045454558529
Customs tariff number	85444290900

Product Classification

UNSPSC	26121629
eCl@ss 10.0	27-44-06-04
eCl@ss 9.0	27-44-06-04
ETIM 9.0	EC002587
ETIM 10.0	EC002587
ECCN	NO US CLASSIFICATION

Environmental Product Compliance	
RoHS Compliance Status	Compliant, No Exemption

Approvals / Certificates

General approvals			Declarations of conformity and manufacturer's declarations		
 					
Approval	Standard	Certificate Name	Approval	Standard	Certificate Name
CCA DEKRA Certification B.V.	EN 61535	NTR NL-7972	EU-Declaration of Confor- mity WAGO GmbH & Co. KG	-	-
KEMA/KEUR DEKRA Certification B.V.	EN 61535	71-123834	UK-Declaration of Confor- mity WAGO GmbH & Co. KG	-	-

Downloads

Environmental Product Compliance	
Compliance Search	
Environmental Product Compliance 771-8965/007-201	↓

Documentation

Bid Text			
771-8965/007-201	19.02.2019	xml 2.96 KB	↓
771-8965/007-201	12.03.2015	doc 25.00 KB	↓

CAD/CAE-Data

CAE data	
EPLAN Data Portal 771-8965/007-201	↓
WSCAD Universe 771-8965/007-201	↓

1 Compatible Products

1.1 Required Accessories

1.1.1 Locking system

1.1.1.1 Locking system



Item No.: 770-101

Locking lever; for flying leads; for manual operation; black

Item No.: 770-121

Locking lever; for flying leads; for manual operation; white

Item No.: 770-111

Locking lever; for flying leads; for tool operation; black

Item No.: 770-131

Locking lever; for flying leads; for tool operation; white

1.2 Optional Accessories

1.2.1 Cover

1.2.1.1 Cover



Item No.: 770-201

Lockout cap; 12-pole, separable; for sockets; Plastic; black

Item No.: 770-221

Lockout cap; 12-pole, separable; for sockets; Plastic; white

Item No.: 770-360

Lockout cap; for plugs; 5-pole; separable; yellow

Item No.: 897-2005

Protective cap; Type4; for sockets and plugs; PVC; red

1.2.2 Installation

1.2.2.1 Mounting accessories



Item No.: 770-310

Mounting carrier; 2- to 5-pole; for flying leads; black

1.2.3 Marking

1.2.3.1 Marker



Item No.: 770-450/000-006

Marker card; Plastic; blue

Item No.: 770-450/000-001

Marker card; Plastic; green

Item No.: 770-450/000-012

Marker card; Plastic; orange

Item No.: 770-450/000-005

Marker card; Plastic; red



Item No.: 770-450

Marker card; Plastic; white

Item No.: 770-450/000-002

Marker card; Plastic; yellow

1.2.3.2 Marking strip



Item No.: 210-334

Marking strips; as a DIN A4 sheet; Strip width 5 mm; Strip length 182 mm; plain; Self-adhesive; white

Installation Notes



Lift jumper out of delivery position (L2) using a screwdriver and move it into the desired position.



Push down jumper in its new position (picture shows L3).

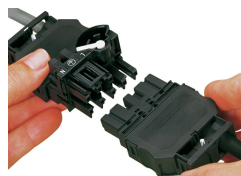

The 5-pole energy circuit can be extended using pluggable cable assemblies.



Plugging a 3-pole tap-off cable.