

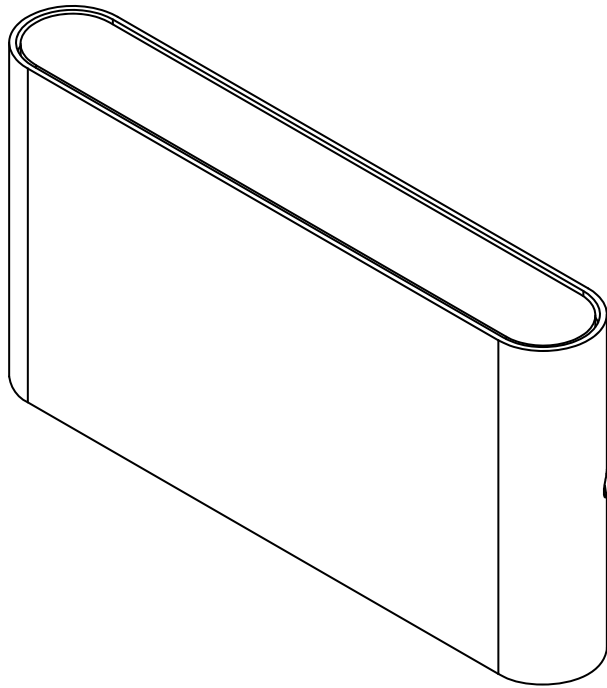

Read these instructions & save for future use

## Wall lamp | up & down 175x90mm | black | 12,9W | 2700K | opal



Article number **149-157**

Brand **Tronix Lighting**

Type **Wall lighting**

Contents of this product **1x 12,9W wall light 2700K**

Technical datasheet **Digitally available  
on our webshop**



*View instructions and  
technical data also on  
our website*

**TRONIX**



## Before first use

Before getting started with this product, it is advisable to check the order completeness and any damage. If this is the case, please contact Tronix Lighting.

## Description

This up and down light is applicable in many spaces due to its flat and sleek design. Think of residential spaces, reception areas or hospitality industry. In addition, the fixture has a connection block inside the fixture so that the connection can be concealed dust and splash-proof (IP54).

### Features

- High quality finish and sleek design;
- 50.000 burning hours;
- Up- and downlight with a beam angle of 90°.

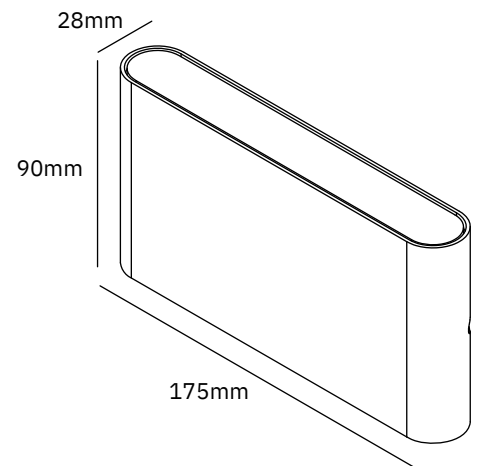

## Installation

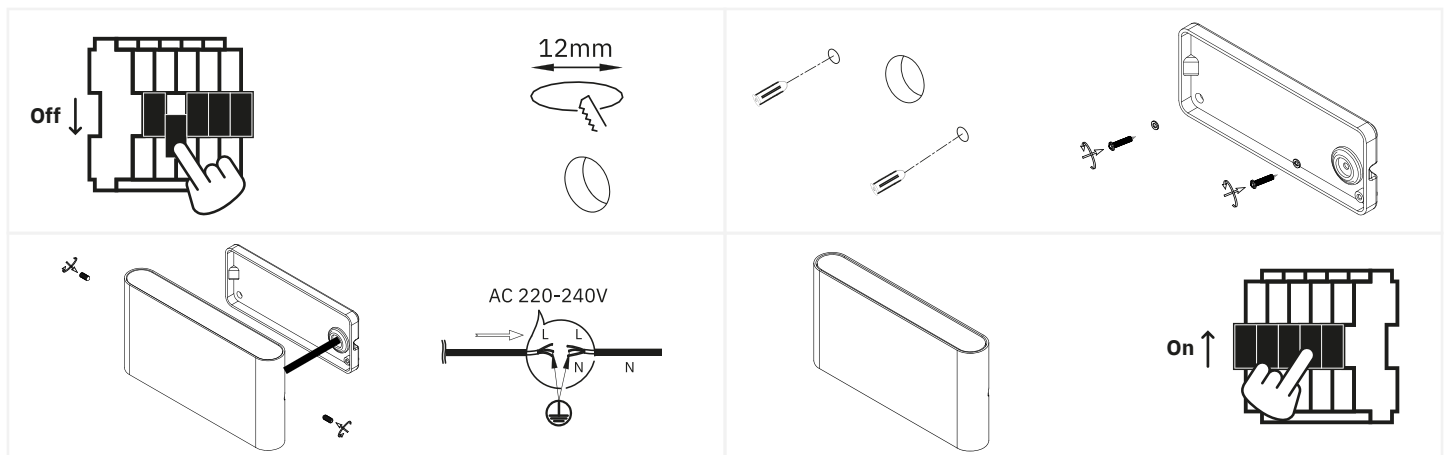

1. Turn off the power and remove the product and associated parts from the packaging. Then cut a hole approximately 12mm in diameter to mount the wall light on;
2. Drill the necessary holes around around the hole and place the back plate against the wall. Then attach it using the screws provided;
3. Connect the existing wiring to the lamp and then secure the shade against the back plate;
4. Check the installation of the wall lamp. Activate the power when this is in order to complete the installation.



## Safety

Safety is a top priority at Tronix Lighting. Therefore, we heartily recommend that you follow the following steps closely:

- Keep this manual carefully for future reference;
- Choose a qualified electrician while installing, maintaining or inspecting this product;
- Never look directly into a light source to avoid possible eye damage;
- Ensure that the respective power group is always on non-active when the product is connected;
- Use only recommended combinations (LED drivers, controllers or dimmers) to avoid injury or damage to the product;
- The light source of this light is not replaceable. Because of this, you must replace the entire fixture towards the end of its lifespan and it is not recommended to open it.

## Technical problems and repair

Should a product not work properly after installation, or if the product exhibits problems over time, it is advisable to check the following elements:

- Check the wiring and installation of your product;
- Check for the presence of interfering elements such as dust, water or other electronics;
- If possible, try disconnecting the product and testing it in another location to rule out a problem at the location;
- Should you be dealing with a WIFI-based product, check and reset your router's settings.

Should the product still not work after testing, it is recommended to send it in for inspection and/or repair. To do so, please contact Tronix Lighting using nearby details and proof of purchase (packing slip).



CARE



SHARE



CONNECT

### Supplier:

Tronix Lighting B.V

Vluchtoord 41  
5406 XP Uden, Netherlands

+31 (0)413 330 380  
sales@tronixlighting.com

## Terms and symbols (as relevant to product)



The **CE mark** indicates that this product complies with EU regulations on safety, health and environmental protection;



The **WEEE symbol** stands for "Waste Electrical and Electronic Equipment Regulation," a directive on the collection, recycling and recovery of electronic waste;



The **Class I symbol** indicates that this product is protected by means of the additional ground cable. This cable is identified by the yellow/green jacket and is attached to this product.

- This product has an **IP54 rating**. This means that the housing provides protection against touch, but does not provide full protection against dust. No damage if sprayed (10 l/min), regardless of angle.