

HERZ Thermostatic valve TS-120-V-SMART

Connection thread M28x1,5

Data sheet for TS-120-V-SMART 762X, Issue 0524

Dimensions

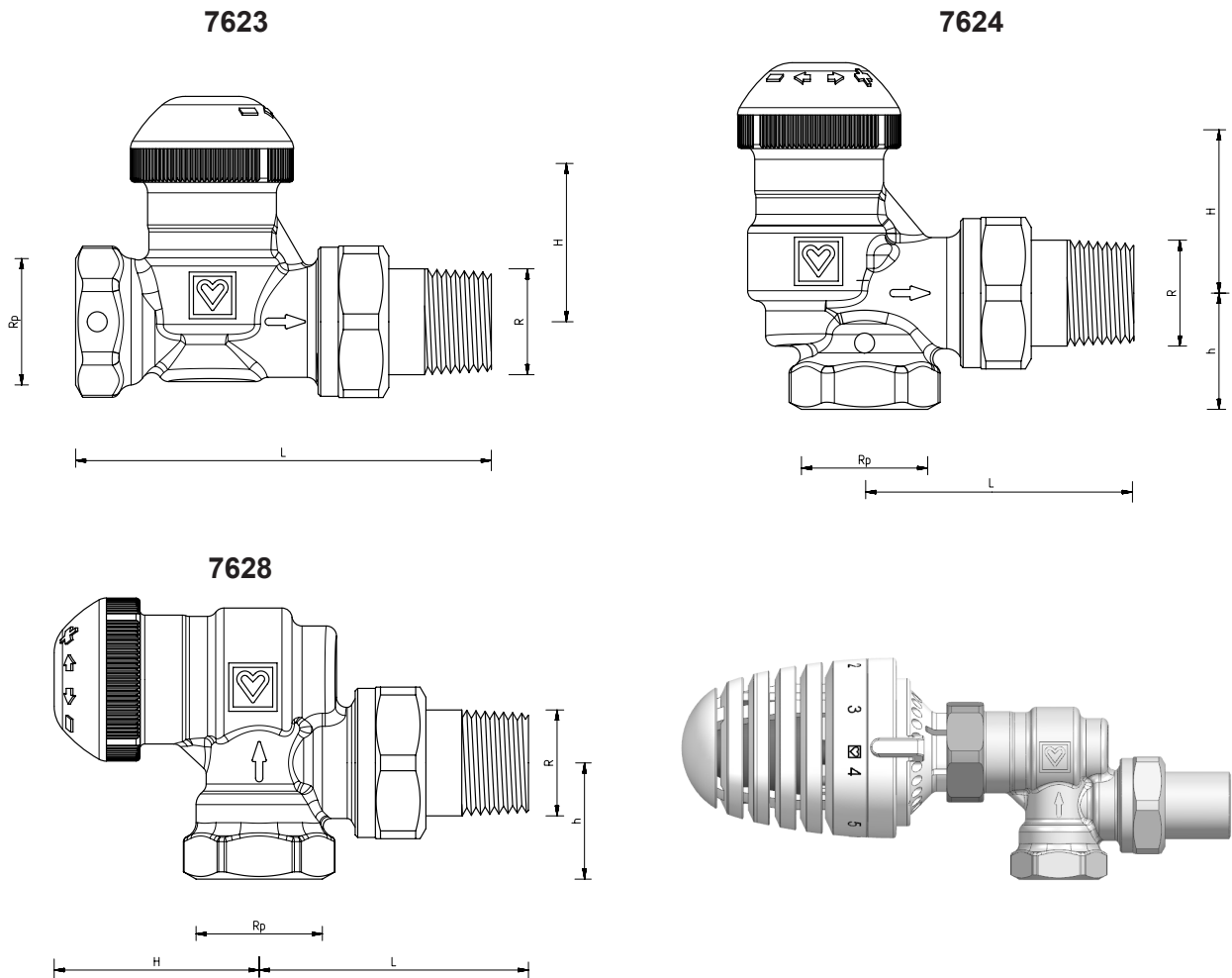

Art. No.	Designation	DN	Rp, "	R, "	L, mm	H, mm	h, mm	k _v value, m ³ /h at 2K
1 7623 51	Dimensional Series "F", Straight Valve	15	1/2	1/2	82,3	31,5	-	0,35
1 7624 51	Dimensional Series "F", Angle Valve	15	1/2	1/2	53,3	32,5	23	0,35
1 7628 51	Dimensional Series "F", Reverse angle model	15	1/2	1/2	53,3	40,6	23	0,35

Operating Data

Maximum operating temperature	120 °C
Maximum operating pressure	10 bar
Regulated flow range	10 l/h – 95 l/h
Fully open, “I” setting	120 l/h
Setting	continuous and readable
Min. differential pressure	10 kPa
Max. differential pressure	60 kPa
Thermostatic head connection	M 28×1,5
Radiator connection	½“ MT (conical screw connection to TS-valve)
Pipe connection	½“ FT

Heating water purity according to Austrian standard ÖNORM H 5195 and/or VDI-guideline 2035.
Ethylene and propylene glycol can be mixed to a ratio of 25 - 50 vol. %

Materials

N	Description	Material
1	Body	DZR Brass
2	Pin	stainless steel
3	Membrane	EPDM
4	O-rings	EPDM
5	Spring	stainless steel
6	Screw connections	DZR Brass
7	Protective cap	plastic

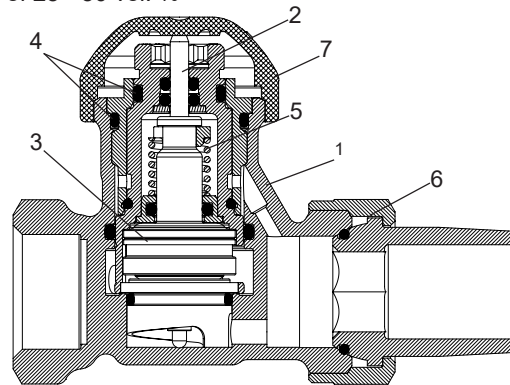

When using HERZ compression unions for copper and steel pipes, observe the permissible temperatures and pressures as specified in EN 1254-2:1998 Table 5. A maximum operating temperature of 95 °C and maximum operating pressure of 10 bar applies for plastic pipe connections, if permitted by the pipe manufacturer.

Field of Application

The thermostatic valve HERZ-TS-120-V-SMART used for temperature control and automatic hydronic balancing in a two-pipe heating and cooling system.

Functionality

The HERZ-TS-120-V-SMART thermostatic valve has an integrated differential pressure regulator. This enables the HERZ-TS-120-V-SMART thermostatic valve to keep the flow rate at the radiator constant under changing pressure conditions. Pressure fluctuations caused by the opening or closing of other radiators in the system are compensated for. Neither system modifications or extensions require readjustment or a change of setting on the HERZ-TS-120-V-SMART thermostatic valve, which keeps the effort for hydraulic balancing low.

The proven HERZ-TS-120-V-SMART thermostatic valve insert in combination with the HERZ thermostatic heads results in a highly efficient and operationally reliable room temperature control.

Installation instructions

Under no circumstances should the HERZ thermostatic head be exposed to direct sunlight or to equipment emitting relevant quantities of heat, e. g. TV sets. If the radiator is covered by curtains this will lead to the formation of a heat accumulation zone in which the thermostat cannot sense the room temperature properly and consequently cannot control it. In such cases, use the HERZ thermostat with remote sensor or the HERZ thermostat with remote adjustment.

For detailed information on the HERZ thermostats consult the individual data sheets.

☑ Installation

The lower part of the thermostatic valve HERZ-TS-120-V-SMART is incorporated into the radiator intake with the flow in the installation direction of the arrow (arrow on the valve body). If possible, the HERZ thermostatic head should be in a horizontal position in order to permit optimum room temperature control and minimise interference..

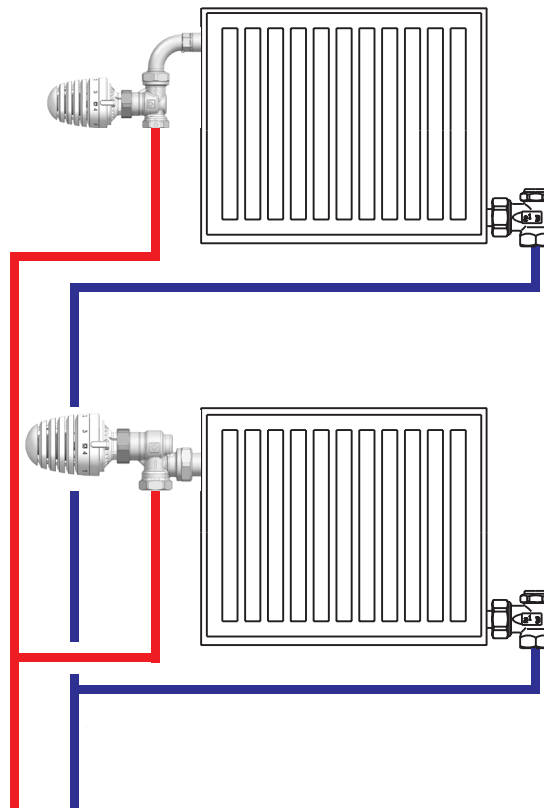

☑ Radiator Connection

Iron pipe connection 6210 with cone seal.

It is recommended that the HERZ assembly key 6680 be used.

☑ Further Connecting Options

Order numbers are available in HERZ product range catalogue.

To be used instead of the radiator connection and on the male thread G 3/4:

6210	1/2	Iron pipe connection, lengths 26 mm and 35 mm.
6211	1/2	Reducing connection, 1/2 x 3/8.
6218	1/2	Long threaded bush, without nut, can be shortened to compensate for differences in structural dimensions, length 1/2 x 76.
6218	1/2	Threaded bush, without nut, lengths 39, 42, 48 and 76 mm.
6235	1/2	Soldering connection, 1/2 x 12, 15 and 18 mm.
6249	1/2	Connection elbow for iron pipes, without nut, with cone seal
6274	G 3/4	Compression union for copper and thin-walled steel pipes, external pipe diameters 8, 10, 12, 14, 15, 16, 18 mm.
6276	G 3/4	HERZ compression union with soft seal for copper and thinwalled steel pipes, particularly suitable for hard special steel pipes and pipes with hard-galvanised surfaces. For external pipe diameters 12, 14, 15, 16 and 18 mm.
6098	G 3/4	HERZ compression union for PE-X-, PB and plastic composite pipes.

For use on the socket side of the valve:

6219	1/2	Reduction socket, brass, for connecting pipe and valve, female thread (pipe) x male thread (valve), 1 x 1/2, 1 1/4 x 1/2.
6066	M 22 x 1,5	Plastic pipe connection for PE-RT-, PE-X-, PB and plastic composite pipes, for use with adapter 1 6272 01 (G 1/2 x M 22 x 1,5).
6098	G 3/4	Plastic pipe connection for PE-RT-, PE-X-, PB and plastic composite pipes, for use with adapter 1 6266 01 (G 1/2 x G 3/4).
6092	G 1/2	Plastic pipe connection for PE-RT-, PE-X-, PB- and plastic composite pipes

For pipe dimensions of plastic pipe connections refer to the HERZ catalogue.

☑ Pipe Connecting, Universal Models

The universal models are equipped with special sockets offering the option of connecting either a threaded pipe or calibrated soft-steel or copper pipe, the latter two by means of a compression union. The compression union must be ordered separately.

When using R = 1/2" valves for external pipe diameters of 10, 12, 14, 16 use adapter Art. No. 6272 between valve and the compression union.

Pipe Ø D mm		10	12	14	15	16
Valve	R =	1/2"				
Adapter	Ord. No.	1 6272 01	1 6272 01	1 6272 01		1 6272 01
Comp. Union	Ord. No.	1 6284 00	1 6284 01	1 6284 03	1 6292 01	1 6284 05

We recommend use of support sleeves for the installation of soft steel or copper pipes with compression unions. For perfect installation, it is imperative to lubricate the thread of the locking nut (male thread and female thread) as well as the olive itself with silicon oil. We refer to our instructions for installation.

☑ Summer Setting of the thermostatic head

After the end of the heating period open thermostats or handwheels completely by turning anticlockwise, this prevents dirt particles accumulating at the valve seat.

☑ Presetting

The respective setting of the control unit is clearly readable and displayed from 1 to 6. The thermostatic valve HERZ-TS-120-V-SMART is preset with the HERZ setting key 1 4006 02. At position "I" the thermostatic valve is fully open. This setting can be used for flushing. Settings between 6 and "I" or 1 and "I" are not permitted.

Increase flow = clockwise

Reduce flow = anticlockwise

1 4006 02

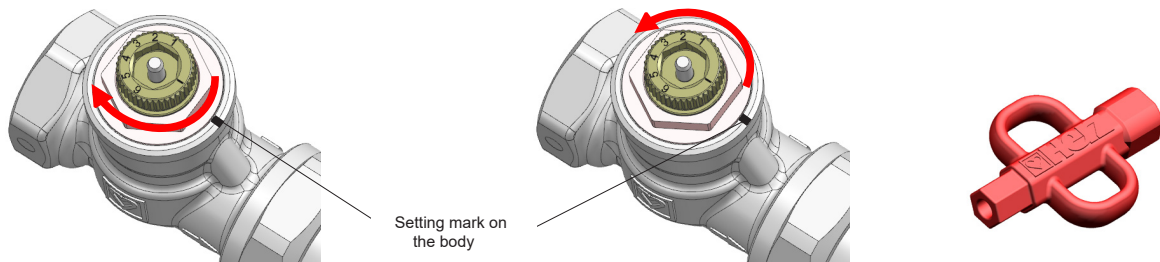

☑ Interpretation

The flow rate calculation is based on the following formula:

$$V = \frac{3600 \times Q}{c \times \rho \times \Delta T} \times 1000, [l/h]$$

V ... volume flow [l/h]
 Q ... heat output [kW]
 c ... specific heat capacity 4.19 [kJ/kgK]
 ρ ... density of water [kg/m³]
 ΔT ... temperature difference flow and return [K]

The diagram can be used to determine the presetting to be made to achieve the required flow.

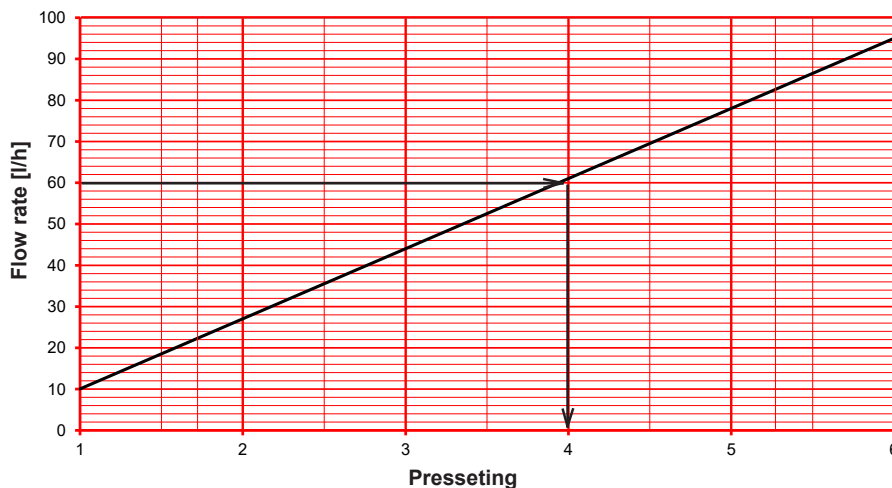

Spare Parts

1 **XXXX** xx Thermostatic upper parts, order numbers available in HERZ product range catalogue.

Accessories

1 **6680** 00 HERZ assembly key for connections
 1 **6807** 90 HERZ-TS-90 assembly key
 1 **9102** 80 HERZ-design hand wheel
 1 **7708** XX HERZ actuating drive
 1 **7990** XX HERZ- actuating drive for continuous control
 1 **4006** 02 Pre-setting key

Accessories- Thermostatic head

Artikelnummer Thermostatkopf	Beschreibung
1 72XX XX	HERZ-Thermostatic heads with threaded connection M 28 x 1,5, with liquid sensor (hydrosensor).
1 9200 XX	HERZ-Design-Thermostatic heads MINI with threaded connection M 28 x 1,5, with liquid sensor (hydrosensor).
1 9220 0X	HERZ-Design-Thermostatic heads MINI GS with threaded connection M 28 x 1,5, with liquid sensor (hydrosensor).
1 9240 0X	HERZ-Design-Thermostatic heads MINI Turbo with threaded connection M 28 x 1,5, with liquid sensor (hydrosensor).
1 92XX 06	HERZ-Design-Thermostatic heads with threaded connection M 28 x 1,5, with liquid sensor (hydrosensor).
1 986X XX	HERZCULES“, HERZ-Thermostatic heads in robust design with threaded connection M 28 x 1,5, with liquid sensor (hydrosensor)

Material

Pursuant to Article 33 of the REACH Regulation (EC No. 1907/2006), we are obliged to point out that the material lead is listed on the SVHC list and that all brass components manufactured in our products exceed 0.1% (w / w) lead (CAS: 7439-92-1 / EINECS: 231-100-4). Since lead is a component part of an alloy, actual exposure is not possible and therefore no additional information on safe use is necessary.

Disposal

Local and currently applicable legislation must be observed for disposal. The disposal of HERZ-TS-120-V-SMART thermostatic valves must not endanger the health or the environment.

All specifications and statements within this document are according to information available at the time of printing and meant for informational purpose only. Herz Armaturen reserves the right to modify and change products as well as its technical specifications and/or its functioning according to technological progress and requirements. It is understood that all images of Herz products are symbolic representations and therefore may visually differ from the actual product. Colours may differ due to printing technology used. In case of any further questions don't hesitate to contact your closest HERZ Branch-office.

