

**Data Sheet | Item Number: 2060-451/998-404**

SMD PCB terminal block; push-button; 0.75 mm<sup>2</sup>; Pin spacing 4 mm; 1-pole; Push-in  
CAGE CLAMP®; in tape-and-reel packaging; white

<https://www.wago.com/2060-451/998-404>



Color: ■ white

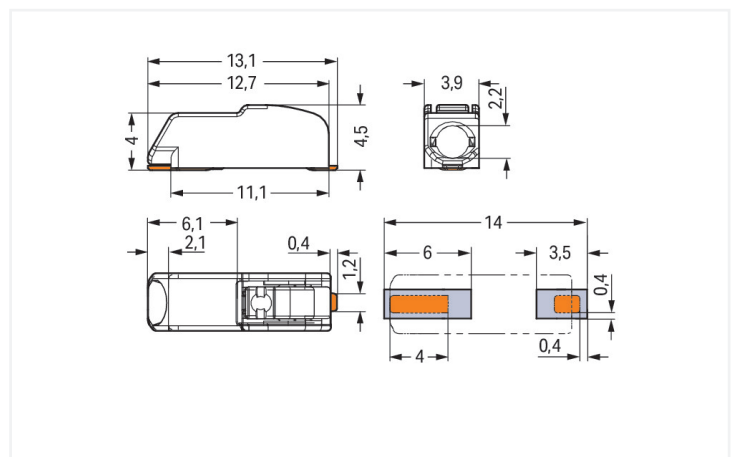
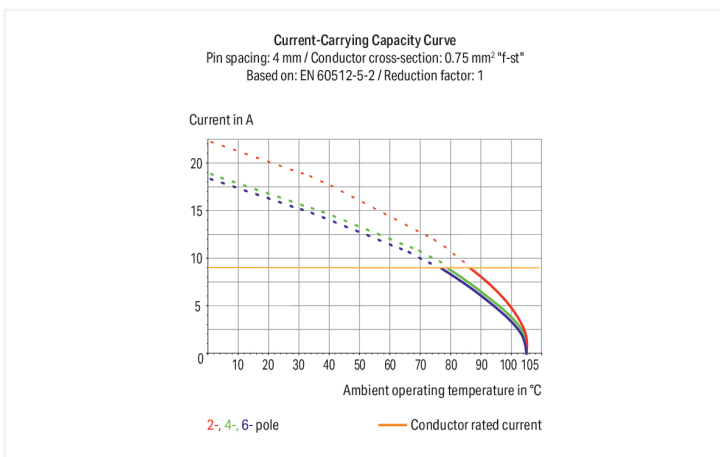

Dimensions in mm

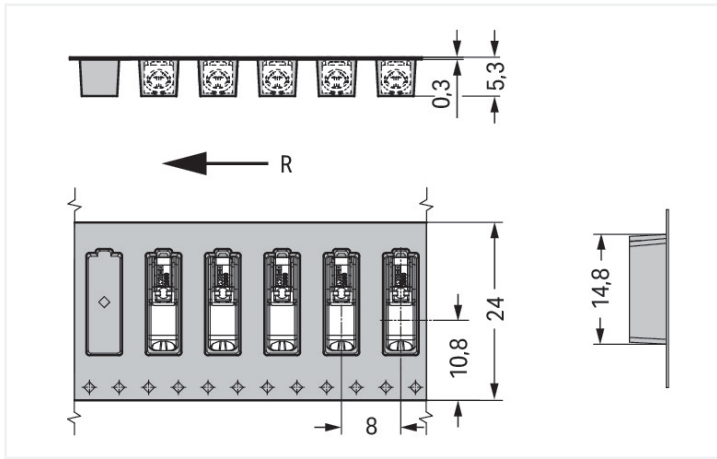

Dimensions in mm  
R = feed direction

PCB terminal block, 2060 Series, 0° conductor entry to board

This PCB terminal block (item number 2060-451/998-404) is designed to connect conductors quickly and easily. It is a universal connector that can be used practically anywhere, for example, as a pluggable PCB connector, panel feedthrough header, connector for rail-mount terminal blocks, or a floating connector for different mounting methods. Ensure that the strip lengths are between 7 and 9 mm when connecting conductors to this PCB terminal block. This product features one conductor terminal and utilizes Push-in CAGE CLAMP®. Push-in CAGE CLAMP® connection technology is ideal for connecting all conductor types. Solid and fine-stranded conductors with ferrules can be pushed in without the need for tools—all thanks to its pluggable design. The item's dimensions are (3.9 x 4.5 x 13.1) mm (width x height x depth). Depending on the type of conductor, this PCB terminal block is suitable for conductor cross sections ranging from 0.2 mm² to 0.75 mm².

The contact surface is coated with tin. This PCB terminal block is operated with a push-button. SMD is used to assemble the PCB terminal block. The conductor is designed to be inserted at an angle of 0°.

Notes	
Note	<p>Application notes: Suitable for lead-free, reflow-soldering profiles per DIN EN 61760-1 and IEC 60068-2-58 up to max. 260°C peak temperature. Due to application-specific variables (component configuration and orientation, type of soldering machine, solder paste), trial runs are recommended to ensure product and process compatibility under actual manufacturing conditions.</p> <p>Depending on reflow soldering temperatures and times, color deviations may occur. These deviations will have no impact on functionality.</p>
Recommendation	<p>Recommendation for stencil: 150 µm material thickness; Pattern layout identical to solder pad layout</p>

Electrical data				
Ratings per	IEC/EN 60664-1			Ratings
Overvoltage category	III	III	II	Approvals per
Pollution degree	3	2	2	UL 1977
Nominal voltage	63 V	160 V	320 V	Rated voltage
Rated impulse withstand voltage	2.5 kV	2.5 kV	2.5 kV	600 V
Rated current	9 A	9 A	9 A	Rated current
				9 A

## Connection Data

Clamping units	1	<b>Connection 1</b>	
Total number of potentials	1	Connection technology	Push-in CAGE CLAMP®
Number of connection types	1	Actuation type	Push-button
Number of levels	1	Solid conductor	0.2 ... 0.75 mm <sup>2</sup> / 24 ... 18 AWG
		Fine-stranded conductor	0.2 ... 0.75 mm <sup>2</sup> / 24 ... 18 AWG
		Fine-stranded conductor; with insulated ferrule	0.25 ... 0.34 mm <sup>2</sup>
		Fine-stranded conductor; with uninsulated ferrule	0.25 ... 0.34 mm <sup>2</sup>
		Strip length	7 ... 9 mm / 0.28 ... 0.35 inches
		Conductor connection direction to PCB	0°
		Pole number	1

## Physical data

Pin spacing	4 mm / 0.157 inches
Width	3.9 mm / 0.154 inches
Height	4.5 mm / 0.177 inches
Depth	13.1 mm / 0.516 inches
Reel diameter of tape-and-reel packaging	330 mm
Tape width	24 mm

## PCB contact

PCB contact	SMD
Solder pin arrangement	over the entire terminal strip (in-line)
Number of solder pins per potential	2

## Material data

Note (material data)	<a href="#">Information on material specifications can be found here</a>
Color	white
Material group	I
Insulation material (main housing)	Polyphthalamide (PPA GF)
Flammability class per UL94	V0
Clamping spring material	Copper alloy
Contact material	Copper alloy
Contact Plating	Tin
Fire load	0.007 MJ
Weight	0.2 g
MSL per J-STD 020D	1

## Environmental requirements

Limit temperature range	-60 ... +105 °C	<b>Environmental Testing</b>	
		Test specification: Railway applications – Rolling stock – Electronic equipment	DIN EN 50155 (VDE 0115-200):2022-06
		Test procedure: Railway applications – Rolling stock equipment – Vibration and shock tests	DIN EN 61373 (VDE 0115-0106):2011-04
		Spectrum/Mounting location	Service life test, Category 1, Class A/B
		Functional test with noise-like oscillations	Test passed according to Section 8 of the standard

### Environmental Testing

Frequency	$f_1 = 5 \text{ Hz}$ to $f_2 = 150 \text{ Hz}$
Acceleration	0.101g (highest test level used for all axes)
Test duration per axis	10 min.
Test directions	X, Y and Z axes
Monitoring of contact faults and interruptions	Passed
Voltage drop measurement before and after each axis	Passed
Simulated service life test through increased levels of noise-like oscillations	Test passed according to Section 9 of the standard
Frequency	$f_1 = 5 \text{ Hz}$ to $f_2 = 150 \text{ Hz}$
Acceleration	0.572g (highest test level used for all axes)
Test duration per axis	5 h
Test directions	X, Y and Z axes
Extended testing: Monitoring of contact faults and interruptions	Passed
Extended testing: Voltage drop measurement before and after each axis	Passed
Shock test	Test passed according to Section 10 of the standard
Shock pulse form	Half sine
Acceleration	5g (highest test level used for all axes)
Shock duration	30 ms
Number of shocks (per axis)	3 pos. und 3 neg.
Test directions	X, Y and Z axes
Extended testing: Monitoring of contact faults and interruptions	Passed
Extended testing: Voltage drop measurement before and after each axis	Passed
Vibration and shock stress for rolling stock equipment	Passed

### Commercial data

Product Group	33 (SMT Terminal)
PU (SPU)	13500 (1500) pcs
Packaging type	Box
Country of origin	CH
GTIN	4055143888172
Customs tariff number	85369010000

### Product Classification

UNSPSC	39121409
eCl@ss 10.0	27-14-11-06
eCl@ss 9.0	27-14-11-06
ETIM 9.0	EC001284
ETIM 10.0	EC001284
ECCN	NO US CLASSIFICATION

**Environmental Product Compliance**

RoHS Compliance Status	Compliant, No Exemption
------------------------	-------------------------

**Approvals / Certificates**

**General approvals**



Approval	Standard	Certificate Name
CCA DEKRA Certification B.V.	EN 60998	NTR NL 7725/M1
CCA DEKRA Certification B.V.	EN 60838	NTR NL 2168246
CCA DEKRA Certification B.V.	EN 60947-7-4	NTR NL-7843/1
cURus Underwriters Laboratories Inc.	UL 1977	E45171
KEMA/KEUR DEKRA Certification B.V.	EN 60838	2168246.01
KEMA/KEUR DEKRA Certification B.V.	EN 60947	71-108183
KEMA/KEUR DEKRA Certification B.V.	EN 60998	71-109040
KEMA/KEUR DEKRA Certification B.V.	EN 60947-7-4	71-114208
UL Underwriters Laboratories Inc.	UL 1059	E45172

**Declarations of conformity and manufacturer's declarations**



Approval	Standard	Certificate Name
EU-Declaration of Confor- mity WAGO GmbH & Co. KG	-	-
Railway WAGO GmbH & Co. KG	-	Z00004396.000
UK-Declaration of Confor- mity WAGO GmbH & Co. KG	-	-

**Downloads**



**Environmental Product Compliance**

Compliance Search	
Environmental Product Compliance 2060-451/998-404	↓



**Documentation**

Additional Information			
Technical Section	03.04.2019	pdf 2027.26 KB	↓

CAD/CAE-Data

CAD data	CAE data
<a href="#">2D/3D Models</a> 2060-451/998-404 	<a href="#">ZUKEN Portal</a> 2060-451/998-404 

PCB Design

<a href="#">Symbol and Footprint via SamacSys</a> 2060-451/998-404 
<a href="#">Symbol and Footprint via Ultra Librarian</a> 2060-451/998-404 

1 Compatible Products

1.1 Optional Accessories

1.1.1 Board-to-board link

1.1.1.1 Board-to-board link



[Item No.: 2060-951/028-000](#)  
 Board-to-Board Link; Pin spacing 4 mm; 1-pole; Length: 28 mm; white

1.1.2 Ferrule

1.1.2.1 Ferrule



[Item No.: 216-301](#)  
 Ferrule; Sleeve for 0.25 mm<sup>2</sup> / AWG 24; insulated; electro-tin plated; yellow



[Item No.: 216-131](#)  
 Ferrule; Sleeve for 0.25 mm<sup>2</sup> / AWG 24; uninsulated; electro-tin plated; silver-colored



[Item No.: 216-302](#)  
 Ferrule; Sleeve for 0.34 mm<sup>2</sup> / 22 AWG; insulated; electro-tin plated; light turquoise



[Item No.: 216-132](#)  
 Ferrule; Sleeve for 0.34 mm<sup>2</sup> / AWG 24; uninsulated; electro-tin plated

1.1.3 Tool

1.1.3.1 Operating tool



[Item No.: 206-860](#)  
 Operating tool; for 2060 Series; multicoloured



[Item No.: 2060-189](#)  
 Operating tool; made of insulating material; for 2060 Series; white

## Installation Notes

### Conductor termination



Insert solid conductors via push-in termination.

### Conductor termination

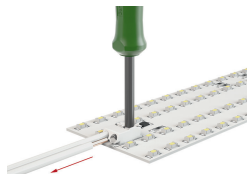

Insert/remove fine-stranded conductors by lightly pressing on push-button, e.g., via optional operating tool (206-860).



Terminal blocks can be arranged side-by-side without loss of poles.