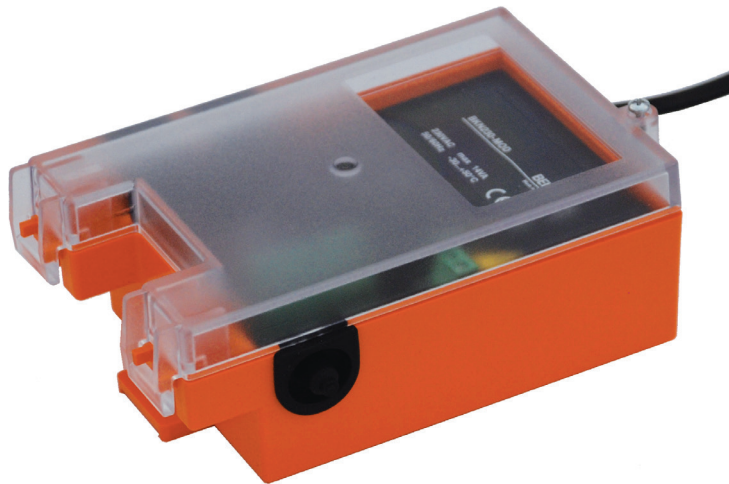

Communication and power supply unit for motorised fire dampers

- Communication via Modbus RTU (RS-485)
- AC 230 V supply via Euro plug
- Power is supplied to the actuators via terminal connection (AC 230 V)
- Simple integration of a smoke detector with no additional power supply is possible
- Suitable actuators:  
BF230.., BFN230.., BFL230..

**Technical data**

<b>Electrical data</b>	Nominal voltage	AC 230 V, 50/60 Hz	
	Nominal voltage range	AC 198...264 V	
	Power consumption	In operation	3.5 W (operating position, incl. actuator)
		For wire sizing	14 VA (incl. actuator)
	Connections	See "Connections" on page 2	
	<b>Modbus</b>		
	Protocol	Modbus RTU	
	Medium	RS-485	
	Transmission formats	1-8-N-2, 1-8-N-1, 1-8-E-1, 1-8-O-1 Default: 1-8-N-2 (Start bits, Data bits, Parity, Stop bits)	
	Number of nodes	Max. 64 (without repeater)	
Baud rates	9,600, 19,200, 38,400, 76,800 Bd Default: 38,400 Bd		
Addresses	1...247, values over 247 are interpreted as 247, 0 = Broadcast		
Bus termination	150 Ω, can be switched if necessary		
<b>Safety</b>	Protection class	II Protective insulated <input type="checkbox"/>	
	Degree of protection	IP40	
	EMC	CE according to 2004/108/EC	
	Low-voltage-directive	CE according to 2006/95/EC	
	Mode of operation	Type 1 (EN 60730-1)	
	Rated impulse voltage	2.5 kV (EN 60730-1)	
	Control pollution degree	2 (EN 60730-1)	
	Ambient temperature	-20...+50 °C	
	Non-operating temperature	-40...+80 °C	
	Humidity test	95% r.h., non-condensing (EN 60730-1)	
Maintenance	Maintenance-free		
<b>Dimensions / Weight</b>	Dimensions	See "Dimensions" on page 5	
	Weight	Approx. 400 g	

**Safety notes**



- The device has been designed for use in stationary heating, ventilation and air-conditioning systems and is not allowed to be used outside the specified field of application, especially in aircraft or in any other airborne means of transport.
- Only authorised specialists may carry out installation.  
All applicable legal or institutional installation regulations must be complied with during installation.
- The device may only be opened at the manufacturer's site. It does not contain any parts that can be replaced or repaired by the user.
- The device contains electrical and electronic components and is not allowed to be disposed of as household refuse. All locally valid regulations and requirements must be observed.

**Product features**

- Application** The BKN230-MOD is installed with the motorised fire damper. This unit sets up the communication connection with higher-level systems. The actuator is connected to a terminal connection for AC 230 V.

Product features

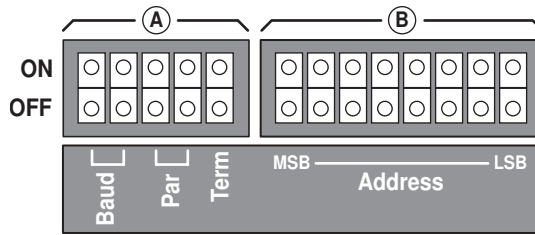
Parameterisation (DIL switch)



A Baud rate			Parity			Termination	
9,600	OFF	OFF	1-8-N-2	OFF	OFF	OFF	OFF
19,200	OFF	ON	1-8-N-1	OFF	ON	Modbus with 150 Ω	ON
38,400	ON	OFF	1-8-E-1	ON	OFF		
76,800	ON	ON	1-8-O-1	ON	ON		

  

B Modbus address								
1	OFF	OFF	OFF	OFF	OFF	OFF	OFF	ON
2	OFF	OFF	OFF	OFF	OFF	OFF	ON	OFF
3	OFF	OFF	OFF	OFF	OFF	OFF	ON	ON
...								
247	ON	ON	ON	ON	OFF	ON	ON	ON

**Test run / fault acknowledgement** Press the button for longer than one second to trigger the following functions:  
 a) starts test run  
 b) resets a current error message

**Expansion options** A BAE...ST thermoelectric tripping device and/or an optoelectronic smoke detector can be connected directly without add-on devices. If a smoke or temperature alarm is tripped, the local damper immediately moves into the safety position and sends a corresponding message to the higher-level system.

**Local override control** If no control commands are received by the BKN230-MOD or if no communication line is connected, the damper remains in the safety position. However, the damper can still move into the operating position by means of the wire bridge (Terminal 1 to 4) as soon as power supply voltage is applied. The BKN230-MOD can thus be used without a control system, for example if the damper needs to be continuously open without remote monitoring. The local safety function of thermoelectric tripping devices and smoke detectors is not affected. The actual position of the damper is displayed by the LEDs in the device. On-site damper test using the test key is possible.  
 In the case of override control (terminal 1+4), stored thermoelectric tripping device / smoke detector faults must first be reset before the damper can be started up. The reset is executed via test button (test run / fault acknowledgement).

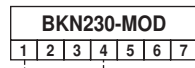

Electrical installation

① Halogen-free power supply cable and plug, AC 230 V

- ② Connecting terminals for
- 1 External smoke detector, +24 V, max. 50 mA
  - 2 External smoke detector, control input
  - 3 GND
  - 4 BKN Direct Control, override control input
  - 5 Modbus GND
  - 6 Modbus D+
  - 7 Modbus D-

③ Tab connection for  
BAE.. thermoelectric tripping device

④ Connecting terminals for  
BELIMO damper actuator (motor AC 230 V)

- 1 = N (blue)
- 2 = L1 (brown)

⑤ Connecting terminals for  
BELIMO damper actuator (limit switch)

- 1 ... 6 = S1 ... S6



Modbus wiring

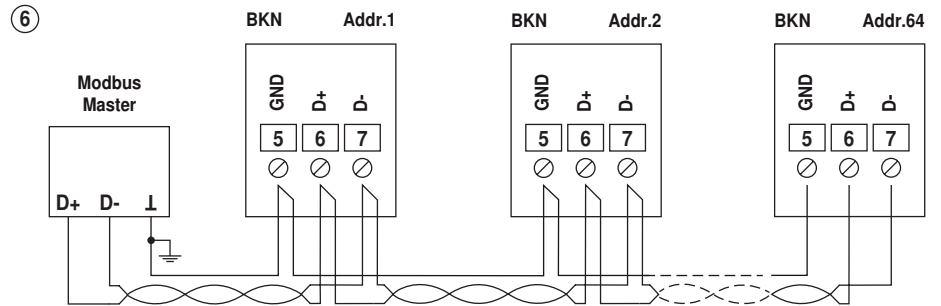

Modbus-GND

Implementation of the bus wiring in 3-wire format is mandatory. The GND must be connected to the protective earth of the control cabinet.

The wiring of Modbus RTU / RS485 is to be carried out in accordance with applicable regulations (www.modbus.org). The device has switchable resistors for bus termination.

Indicators and operating elements

⑦ Button (see "Test run / fault acknowledgement" above)

⑧ DIL switch (see "Parameterisation" above)

⑨ LEDs status signalisation BELIMO damper actuator:

- |        |          |   |
|--------|----------|---|
| Green  | On       | Upper limit switch (damper open)  |
|        | blinking | Damper opens (motor is actuated)  |
| Yellow | On       | Lower limit switch (damper closed)  |
|        | blinking | Damper closes (motor is not actuated)   |
| Red    | On       | Internal device fault (BKN)   |
|        | blinking | External fault = BAE or smoke sensor triggered, nominal position not reached  |
|        | flashing | External fault = If an error is stored (i.e. no longer pending, but not yet acknowledged), then this is displayed on the device by a periodic flash of the red LED. |

⑩ LED Modbus communication:

Yellow flickering Modbus communication is illuminated during RX and TX



Signalisation

Lower limit position (Damper CLOSED) not reached:	Upper limit position (Damper OPEN) not reached:
LED red   blinking	LED red   blinking
LED green  blinking	LED green  off
LED yellow  off	LED yellow  blinking
Signal via LED after 2:30 min	Signal via LED after 2:30 min

## Modbus overview

## Register

	No.	Adr	Register
In operation	1	0	–
	2	1	<b>Override control</b>
	3	2	<b>Command</b>
	4	3	Actuator type
	5	4	Relative position [%]
	6	5	–
	7	6	–
	8	7	–
	9	8	Collective fault
Service	101	100	Series number 1st part
	102	101	Series number 2nd part
	103	102	Series number 4th part
	104	103	Firmware version (Modbus module)
	105	104	Malfunction and service information
	106	105	–
	107	106	–
	108	107	–
	109	108	<b>Bus fail position</b>

- Registers in Bold can be written
- Registers <100 (In operation) which can be written are non-permanent and should therefore be updated periodically
- Registers >100 which can be written are permanent

## Commands

All data is arranged in a table and addressed by 1..n (register) or 0..n-1 (address). No distinction is made between data types (Discrete Inputs, Coils, Input Registers, Holding Registers). As a consequence, all data can be accessed with the two commands for Holding Register. The commands for Discrete Inputs and Input Registers can be used as an alternative.

**Note regarding Read Discrete Inputs**

The command reads one or more bits and can alternatively be applied for reading the malfunction and service information in Register 105 (Adr 104). The Start address for "BAE (duct temperature sensor) triggered" is calculated with  $104 \times 16 + 6 = 1670$

Standard commands:

Read Holding Registers [3]  
Write Single Register [6]

Optional commands:

Read Discrete Inputs [2]  
Read Input Registers [4]  
Write Multiple Registers [16]

## Modbus register description

**Register 2: Override control**

Overriding the setpoint with defined compulsions

**Note**

If no override is set (value 0), then the fire damper remains in safety position (Closed).

<b>Override control</b>	
0	None (initial value, cannot be written)
1	Open
2	Close

**Register 3: Command**

Initiation of actuator functions for service and test; the register is reset automatically.

<b>Command</b>	
0	None
2	Test run
4	Reset faults

**Register 4: Actuator type**

<b>Actuator type</b>	
3	Fire damper actuator

**Register 5: Relative position**

Position in accordance with position indicator switches  
Damper closed: 0 (0%)  
Intermediate switching: 5,000 (50%)  
Damper open: 10,000 (100%)

**Register 9: Collective fault**

0 = no fault  
1 = fault  
Fault is set when one of the bits 0...7 of Register 105 is set.  
(used as sensor value for air/water/VAV)

**Modbus register description**

**Register 101, 103: Series number** Each node has an unambiguous series number. The series number consists of 4 segments, although only parts 1, 2 and 4 are displayed on Modbus.  
Example: 00839-31324-064-008

Register 9	Register 10	Register 11
1st part	2nd part	4th part
00839	31234	008

**Register 104: Firmware Version** Firmware Version (VX.XX)  
e.g. 101 V1.01

**Register 105: Malfunction and service information** The status information is split into messages about the actuator (malfunctions) and other service information.

bit	Description
0	–
1	Actuation path increased
2	Mechanical overload
3	–
4	Safety-relevant malfunction
5	–
6	Duct temperature too high
7	Smoke detector triggered
8	Internal activity (test run, adaption, ...)
9	–
10	Bus monitoring triggered
11	Local override control active
12	–
13	–
14	–
15	–

The malfunction bits can be reset with Register 3 (command 4). Malfunction 4 cannot be reset.

**Register 109: Bus fail position** The bus monitoring controls the Modbus communication. If the override control (Register 2) is not renewed within 300 seconds, the actuator controls to the bus fail position (closed). Triggered bus monitoring is indicated in Register 105.

Bus fail position	
0	No bus monitoring
1	Rapid close if time is exceeded (factory setting)

**Dimensions [mm]**

**Dimensional drawings**

