

Data Sheet | Item Number: 2059-301/998-403

SMD PCB terminal block; 0.5 mm²; Pin spacing 3 mm; 1-pole; PUSH WIRE®; in tape-and-reel packaging; white

<https://www.wago.com/2059-301/998-403>



Color: ■ white

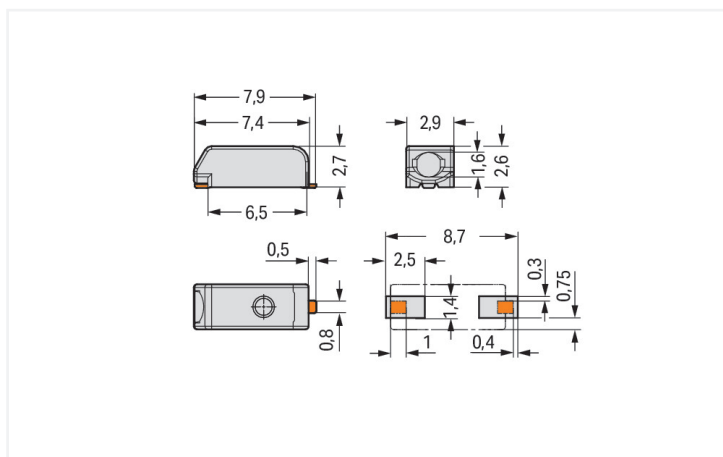

Dimensions in mm

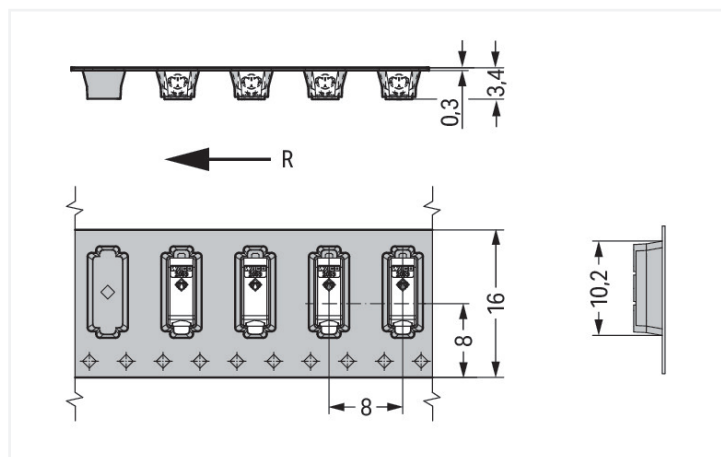

Dimensions in mm
R = feed direction

PCB terminal block, 2059 Series, white

Our PCB terminal block (item number 2059-301/998-403) is designed for seamless electrical installations. It is a universal connector that can be used almost anywhere, for example, as a pluggable PCB connector, panel feedthrough header, connector for rail-mount terminal blocks, or a floating connector for different mounting methods. Ensure that the strip lengths are between 4 and 5.5 mm when connecting conductors to this PCB terminal block.

This product features one conductor terminal and utilizes PUSH WIRE®. Our reliable PUSH WIRE® connection offers the fastest method for clamping conductors. It utilizes the conductor's stiffness to overcome the clamping spring's contact force. The dimensions are (2.9 x 2.7 x 7.9) mm (width x height x depth). Depending on the type of conductor, this PCB terminal block is ideal for conductor cross sections ranging from 0.14 mm² to 0.34 mm² on one side and for conductor cross sections from 0.5 mm² to 0.5 mm² on the other side.

The contact surface is coated with tin. An operating tool is used to operate this PCB terminal block. SMD is used to solder the PCB terminal block. Insert the conductor at a 0° angle..

The 2059 Series SMD PCB Terminal Block is the smallest 2.7 mm terminal block with an insulated plastic housing in the portfolio. The white housing is perfect for use in LED lights and provides minimal shadowing thanks to its small design with rounded corners. WAGO's 2059 Series design is accented by a clean look and characteristic round hole for the operating tool for disconnecting conductors. Thanks to the slim design, terminal blocks can be arranged side-by-side without pole loss and without limitation. The slightly slanted shape of the terminal block front with the balcony-like projection of the underside not only allows a good view from above of the conductor entry hole, it also enables quick and easy insertion of solid conductors.

Notes

Note	<p>Application notes: Suitable for lead-free, reflow-soldering profiles per DIN EN 61760-1 and IEC 60068-2-58 up to max. 260°C peak temperature. Due to application-specific variables (component configuration and orientation, type of soldering machine, solder paste), trial runs are recommended to ensure product and process compatibility under actual manufacturing conditions.</p> <p>Depending on reflow soldering temperatures and times, color deviations may occur. These deviations will have no impact on functionality.</p>
Recommendation	<p>Recommendation for stencil: 150 µm material thickness; Pattern layout identical to solder pad layout</p>

Electrical data

Ratings per	IEC/EN 60664-1			Approvals per	UL 1977
Overvoltage category	III	III	II	Rated voltage	600 V
Pollution degree	3	2	2	Rated current	3 A
Nominal voltage	63 V	160 V	320 V		
Rated impulse withstand voltage	2.5 kV	2.5 kV	2.5 kV		
Rated current	3 A	3 A	3 A		

Connection Data

Clamping units	1	Connection 1	
Total number of potentials	1	Connection technology	PUSH WIRE®
Number of connection types	1	Actuation type	Operating tool
Number of levels	1	Solid conductor	0.14 ... 0.34 mm ² / 26 ... 22 AWG
		Note (conductor cross-section)	For conductors (26 AWG) that are not rigid enough, the clamping unit must be opened using an operating tool.
		Strip length	4 ... 5.5 mm / 0.16 ... 0.22 inches
		Conductor connection direction to PCB	0°
		Pole number	1

Connection 2

Solid conductor	0.5 mm ² / 20 AWG
Note (conductor cross-section)	No reconnection of smaller conductor cross-sections (0.5 mm ² /20 AWG)
Strip length	6 ... 7.5 mm / 0.24 ... 0.3 inches

Physical data

Pin spacing	3 mm / 0.118 inches
Width	2.9 mm / 0.114 inches
Height	2.7 mm / 0.106 inches
Depth	7.9 mm / 0.311 inches
Reel diameter of tape-and-reel packaging	330 mm
Tape width	16 mm

PCB contact

PCB contact	SMD
Solder pin arrangement	over the entire terminal strip (in-line)
Number of solder pins per potential	2

Material data

Note (material data)	Information on material specifications can be found here
Color	white
Material group	I
Insulation material (main housing)	Polyphthalamide (PPA GF)
Flammability class per UL94	V0
Contact material	Copper alloy
Contact Plating	Tin
Fire load	0.002 MJ
Weight	0.1 g

Environmental requirements

Limit temperature range	-60 ... +105 °C
-------------------------	-----------------

Environmental Testing

Test specification: Railway applications – Rolling stock – Electronic equipment	DIN EN 50155 (VDE 0115-200):2022-06
Test procedure: Railway applications – Rolling stock equipment – Vibration and shock tests	DIN EN 61373 (VDE 0115-0106):2011-04
Spectrum/Mounting location	Service life test, Category 1, Class A/B
Functional test with noise-like oscillations	Test passed according to Section 8 of the standard
Frequency	$f_1 = 5 \text{ Hz}$ to $f_2 = 150 \text{ Hz}$
Acceleration	0.101g (highest test level used for all axes)
Test duration per axis	10 min.
Test directions	X, Y and Z axes
Monitoring of contact faults and interruptions	Passed
Voltage drop measurement before and after each axis	Passed
Simulated service life test through increased levels of noise-like oscillations	Test passed according to Section 9 of the standard
Frequency	$f_1 = 5 \text{ Hz}$ to $f_2 = 150 \text{ Hz}$
Acceleration	0.572g (highest test level used for all axes)
Test duration per axis	5 h
Test directions	X, Y and Z axes
Extended testing: Monitoring of contact faults and interruptions	Passed
Extended testing: Voltage drop measurement before and after each axis	Passed

Environmental Testing

Shock test	Test passed according to Section 10 of the standard
Shock pulse form	Half sine
Acceleration	5g (highest test level used for all axes)
Shock duration	30 ms
Number of shocks (per axis)	3 pos. und 3 neg.
Test directions	X, Y and Z axes
Extended testing: Monitoring of contact faults and interruptions	Passed
Extended testing: Voltage drop measurement before and after each axis	Passed
Vibration and shock stress for rolling stock equipment	Passed

Commercial data

Product Group	33 (SMT Terminal)
PU (SPU)	31800 (2650) pcs
Packaging type	Box
Country of origin	CH
GTIN	4055143082679
Customs tariff number	85369010000

Product Classification

UNSPSC	39121409
eCl@ss 10.0	27-14-11-06
eCl@ss 9.0	27-14-11-06
ETIM 9.0	EC001284
ETIM 10.0	EC001284
ECCN	NO US CLASSIFICATION

Environmental Product Compliance

RoHS Compliance Status	Compliant, No Exemption
------------------------	-------------------------

Approvals / Certificates

General approvals



Approval	Standard	Certificate Name
CCA DEKRA Certification B.V.	EN 60947	NTR NL-7819
CCA DEKRA Certification B.V.	EN 60947	71-111131
CCA DEKRA Certification B.V.	EN 60838	NTR NL-7720
KEMA/KEUR DEKRA Certification B.V.	EN 60838	71-106226
UL Underwriters Laboratories Inc.	UL 1977	E45171

Declarations of conformity and manufacturer's declarations



Approval	Standard	Certificate Name
Railway WAGO GmbH & Co. KG	-	Z00004395.000

Downloads

Environmental Product Compliance

Compliance Search

Environmental Product Compliance
2059-301/998-403



Documentation

Additional Information

Technical Section

03.04.2019

pdf

2027.26 KB



CAD/CAE-Data

CAD data

2D/3D Models
2059-301/998-403



CAE data

ZUKEN Portal
2059-301/998-403



PCB Design

Symbol and Footprint
via SamacSys
2059-301/998-403



Symbol and Footprint
via Ultra Librarian
2059-301/998-403



1 Compatible Products

1.1 Optional Accessories

1.1.1 Board-to-board link

1.1.1.1 Board-to-board link



[Item No.: 2059-901](#)

Board-to-Board Link; Pin spacing 3 mm;
1-pole; Length: 15.3 mm; white

[Item No.: 2059-901/018-000](#)

Board-to-Board Link; Pin spacing 3 mm;
1-pole; Length: 17.5 mm; white

[Item No.: 2059-901/021-000](#)

Board-to-Board Link; Pin spacing 3 mm;
1-pole; Length: 20.5 mm; white

1.1.2 Tool

1.1.2.1 Operating tool



[Item No.: 206-859](#)

Operating tool; for 2059 Series; multicoloured

[Item No.: 2059-189](#)

Operating tool; made of insulating material; for 2059 Series

Installation Notes

Conductor termination



Insert solid conductors via push-in termination.

Conductor termination



Easy conductor removal, e.g., via operating tool (Item No. 206-859) or "twist & pull" (max. 10 x, no reconnection of smaller conductors possible)