

**SpiroPure ProClean 23.0**

Klantnaam:

Project:

Referentie:

**Type: G76.362**

**Ontwerp criteria**

Medium:	Water
Capaciteit	1200 l/h
Max. Filling Capacity @420µS/cm to <100µS	3420 l
Minimale systeemdruk:	1,0 bar-g
Maximale systeemdruk:	8,0 bar-g
Minimale temperatuur:	5 °C
Maximale temperatuur:	80 °C

**Aansluitingen**

Intrede / uittrede	G <sup>3/4"</sup>
Dirt Drain	G <sup>3/4"</sup> (M)

**Kwaliteitscontrole**

Testcertificaat:	nee
Materiaalcertificaten:	nee
Compliance:	VDI 2035, ÖNORM H 5195-1 SWKI BT 102-11

**Constructiematerialen**

Kop:	POM
Aansluitingen	Messing
Huls basis	PP
Huls draad:	PA66
Huls wikkeling:	FRP
Huls liner:	HDPE
Trolley	Aluminium, kunststof en rubber
Montagebeugel:	HDPE
LED behuizing:	POM
Cartridge:	Polystyrol
Hars:	Synthetische polymeer
MBL:	Messing

**Tekening**

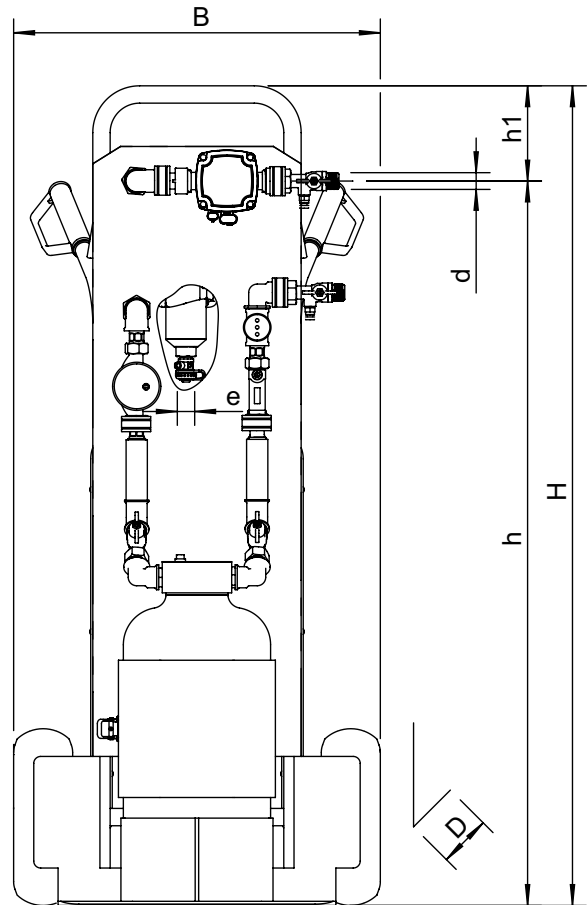

**Afmetingen**

Hoogte:	1182 mm
Breedte:	528 mm
Diepte:	519 mm
B	528 mm
d	G <sup>3/4"</sup>
D	519 mm
e	G <sup>3/4"</sup> (M)
H	1182 mm
h	1045 mm
h1	137 mm
Gewicht:	47,5 kg
Hars volume:	23 l
LED Power:	Battery - CR2450
Pump Power:	230 V

Wijzigingen voorbehouden