

IQ EV Charger 2 Dynamic Load Balancing



Applicable regions: Europe

© 2025 Enphase Energy. All rights reserved. Enphase, the e and CC logos, and certain other marks listed at <https://enphase.com/trademark-usage-guidelines> are trademarks of Enphase Energy, Inc. in the U.S. and other countries. Data subject to change.

Contents

1	Summary.....	3
1.1	IQ EV Charger 2 Dynamic Load Balancing.....	3
1.2	Prerequisite to enable Dynamic Load Balancing feature.....	4
1.3	Installation and configuration of Dynamic Load Balancing using the Enphase Installer App.....	4
1.3.1	Configure the home-contracted power rating.....	4
1.3.2	Establish local connectivity between IQ Gateway and IQ EV Charger 2 and enable Dynamic Load Balancing.....	7
1.4	Failure modes and resolution.....	8
1.5	Viewing the Dynamic Load Balancing status on the Enphase App.....	9
2	Revision history.....	9

1. Summary

This technical brief provides Enphase installers with the adequate information required to enable the Dynamic Load Balancing (DLB) feature for the IQ EV Charger 2. This document is an addendum to the installation configuration document.

1.1 IQ EV Charger 2 Dynamic Load Balancing

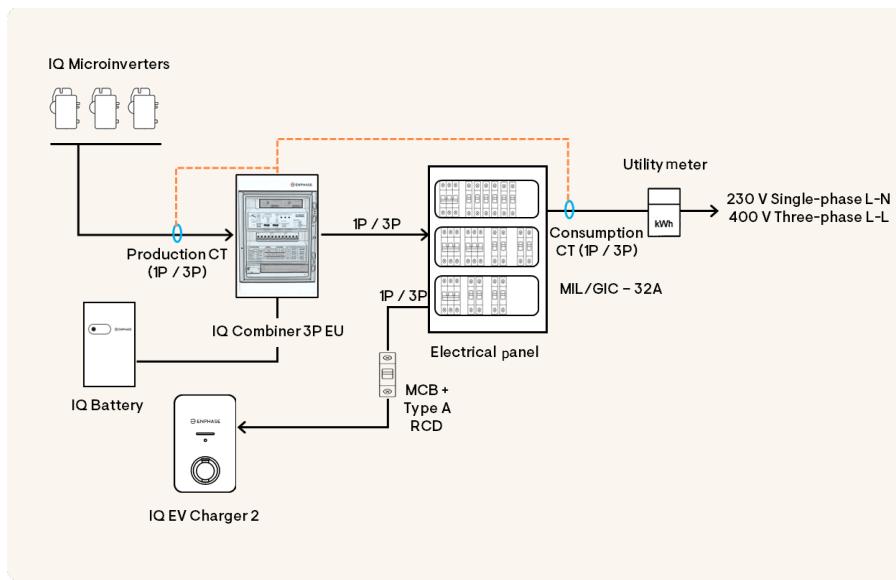

Figure 1: Dynamic Load Balancing for integrated grid-tied system with PV and battery

The Dynamic Load Balancing (DLB) feature enables the dynamic control of EV charging based on the other home loads to ensure that the total load is within the contracted per phase power of the home as defined by MIL (maximum import limit)/GIC (grid interconnection capacity).

This is achieved by integrating the IQ EV Charger with the IQ Gateway Metered through which the EV charger fetches the current and power flow at the grid supply and accordingly controls the EV charging load.

In the case of three-phase configuration, the EV charging is limited based on the minimum power available per phase. The feature also has the intelligence to check if the minimum three-phase power is less than 4.1 kW, then it enables phase-switching to charge in single-phase using the available capacity on phase L1.

Since the phase-switching enables charging using only the L1 phase, it is recommended to connect the phase having the lower loading as L1 as it would help better utilization of the available capacity.

The Dynamic Load Balancing (DLB) feature is supported for all the system configurations that have an IQ Gateway Metered with Consumption CTs along with the PV and battery systems.

It is also supported for a standalone IQ EV Charger with IQ Gateway Metered with Consumption CTs.

1.2 Prerequisite to enable Dynamic Load Balancing feature

To ensure the activation and operation of the Dynamic Load Balancing feature, the following requirements must be met:

- Install Consumption CTs on all three phases (single-phase in case of single-phase charger) between the utility meter and the electrical panel.
- IQ EV Charger firmware version must be 25.7.1.7 or above.
 - During the commissioning, if the version is older, the device will be updated automatically to the latest version. This may take up to 10 minutes and the LED Bar shall also indicate the progress using the left-to-right moving purple colour pattern.
- Enphase Installer App version must be 4.5.0 or higher.
- IQ Gateway software version must be 7.6.168 or above.
- Ensure the IQ Gateway and IQ EV Charger are on the same network.
 - The IQ Gateway can connect to the home network via Wi-Fi or Ethernet.
 - A stable network connection is critical to prevent disconnections between the IQ Gateway and EV charger.
- The IQ EV Charger must be connected to the electrical panel.
- The phase mapping between the IQ EV Charger and the IQ Gateway should be established correctly. This can be updated post-installation using the **EV Charger Settings** in the **Devices** section of the Enphase Installer App.

1.3 Installation and configuration of Dynamic Load Balancing using the Enphase Installer App

Enabling this feature on the Enphase Installer App is a two-step process:

1. Enter the breaker rating (MIL/GIC).
2. Establish connectivity between the IQ Gateway and IQ EV Charger 2.

1.3.1 Configure the home-contracted power rating

For UK sites: Maximum Import Limit (MIL)

1. Go to **Site Configuration > Maximum Import Limit**.
2. Select the DNO contracted power limit in Amperes and press the **OK** button.

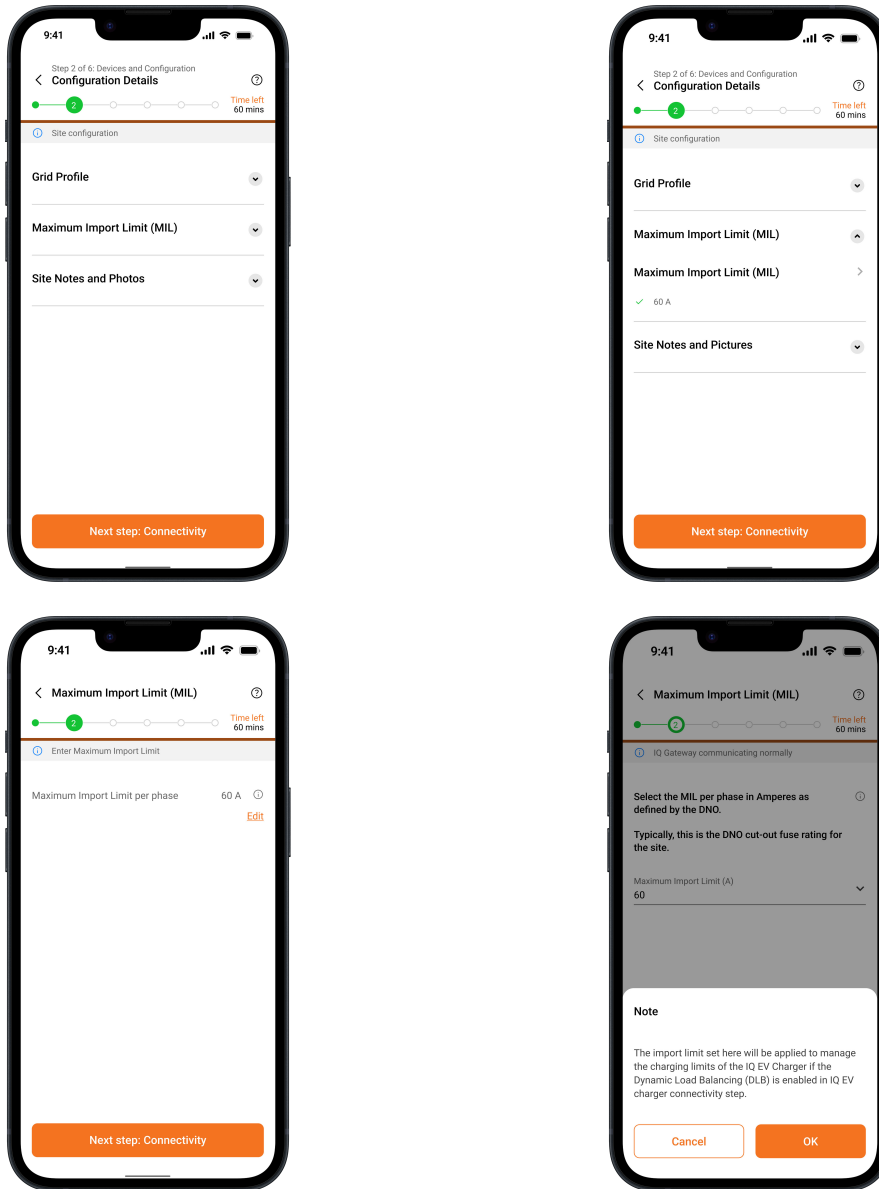

Rest of Europe: Grid Interconnection Capacity (GIC)

1. Go to **Site Configuration > Grid Interconnection Capacity**.
2. Enter the DNO contracted per phase power and press the **OK** button. The rating will be defined in Amperes or kW depending upon your location:
 - Belgium, Germany, Denmark, Finland, Luxembourg, and The Netherlands – in Amperes
 - Austria, Spain, France, Italy, and Portugal – in kW

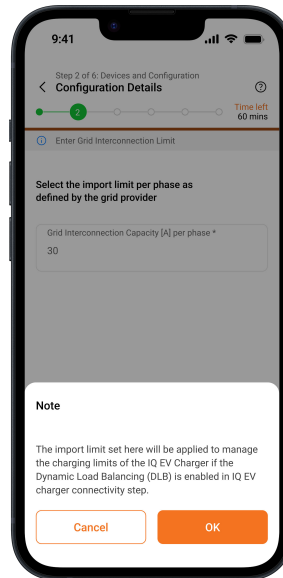
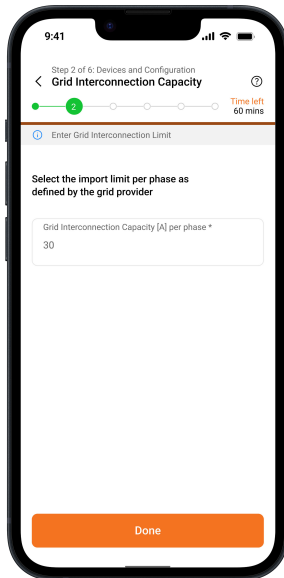
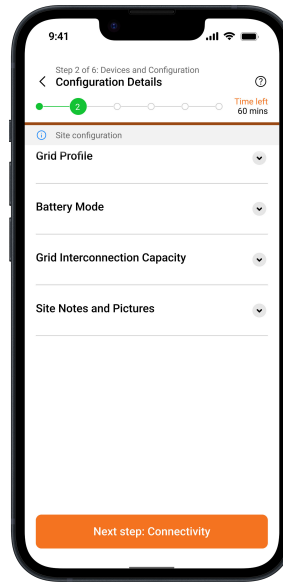
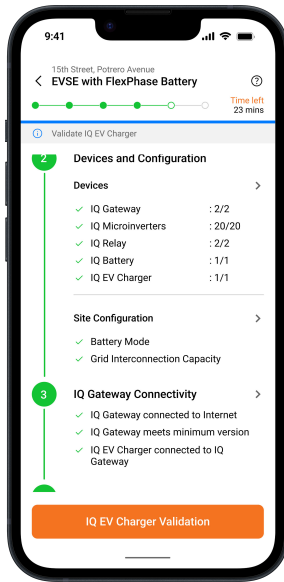

1.3.2 Establish local connectivity between IQ Gateway and IQ EV Charger 2 and enable Dynamic Load Balancing

1. Navigate to section 3 of the Enphase Installer App to enable local connectivity.

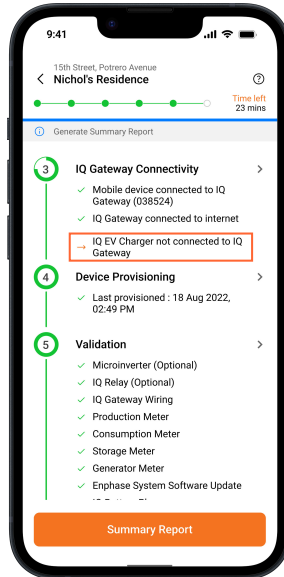

2. Enable the local connectivity between the IQ EV Charger 2 and IQ Gateway as shown below.
 - a. Ensure both devices are on the same network before connecting them.
 - b. Ensure that the firmware version of the IQ EV Charger is higher than 25.7.1.7 (Refer to [Prerequisite to enable Dynamic Load Balancing feature](#) section)

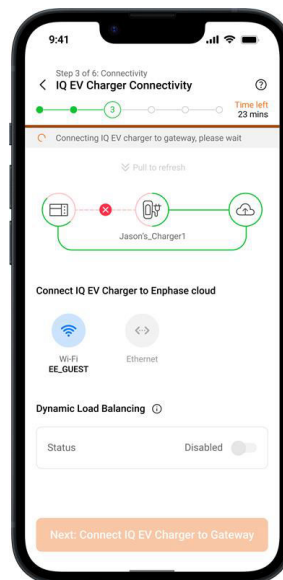
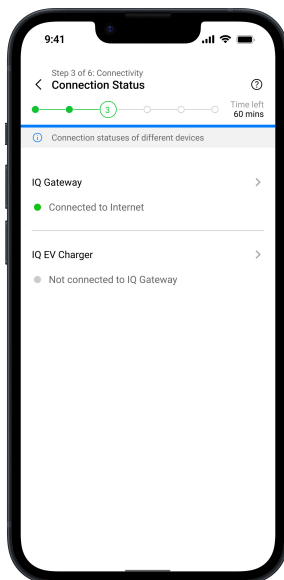

After a successful connection, enable Dynamic Load Balancing. Enabling Dynamic Load Balancing allows you to select one or more IQ EV Chargers that need load balancing based on the total load on the breaker rating. This must be done in addition to entering the **Maximum Import Limit/Grid Interconnection Capacity** in step 2 under **Site Configuration**.

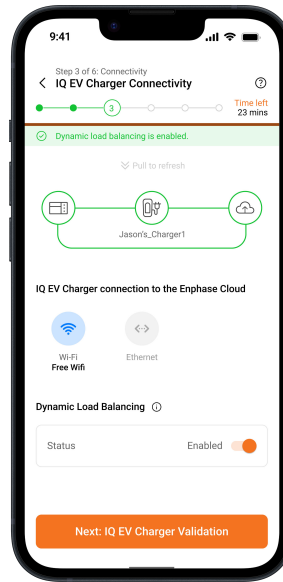
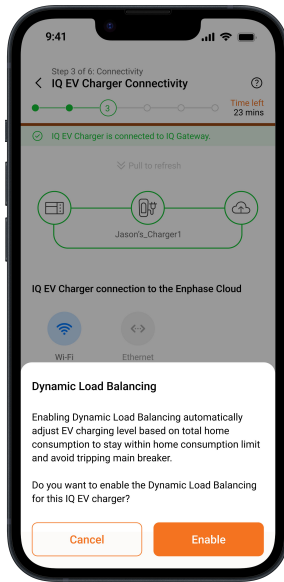

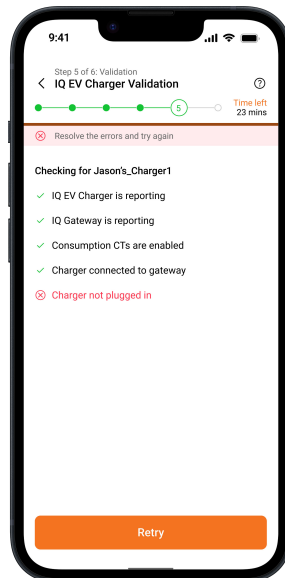

☑ **NOTE:** The last step (Step 5) for IQ EV Charger Validation is an optional step that is currently not supported and should be skipped.



1.4 Failure modes and resolution

1. IQ Gateway failure - IQ EV Charger limits the charge to 8 A (Fail-safe mode).
2. Loss in local connectivity between the IQ EV Charger 2 and IQ Gateway - IQ EV Charger 2 limits the charge to 8 A.

☑ **NOTE:** The IQ EV Charger 2 Dynamic Load Balancing feature functions as expected if the IQ Gateway and IQ EV Charger are connected locally via the home network, even if the home router loses internet access.

- 
NOTE: The IQ EV Charger 2 Dynamic Load Balancing feature functions as expected if the IQ Gateway and IQ EV Charger are connected locally via the home network, even if either or both devices lose internet access.
- 
NOTE: The IQ EV Charger Dynamic Load Balancing feature functions as expected if the IQ Gateway and IQ EV Charger are connected locally via the home network, even if the IQ Gateway is connected to the Enphase App via a cellular network.

1.5 Viewing the Dynamic Load Balancing status on the Enphase App

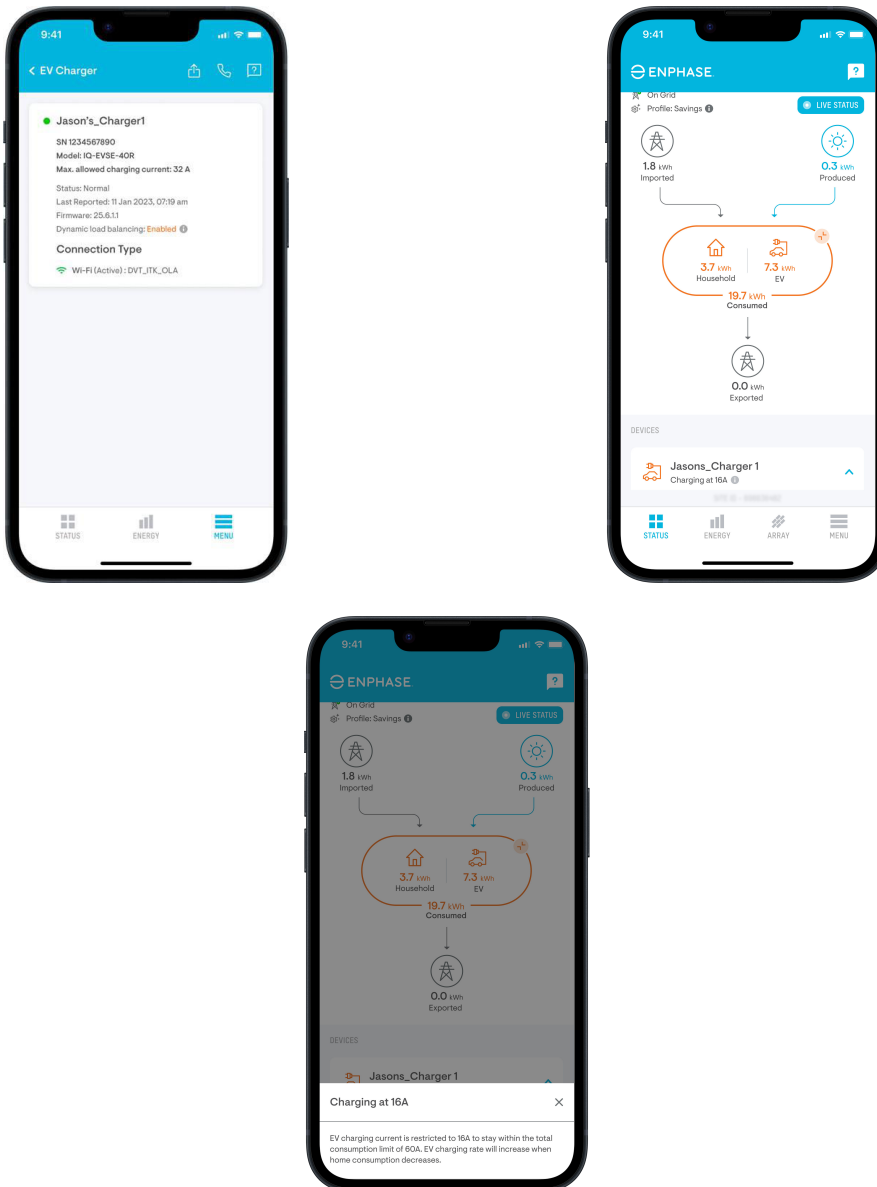

2. Revision history

Revision	Date	Description
TEB-00251-1.0	March 2025	Initial release.