

Presence detector P46LR, DALI-2, secondary - BMS, 32-37 m, for flush mounting (SnapFit), WAGO WINSTA® MIDI 2 m cable with 5-pol. connector, white

353-751021-1



DALI-2



secondary - BMS



IP20



360°



ø 37 m from a height of 3 m



2 m - 3.5 m



flush-mounting (SnapFit)



Bluetooth® Low Energy

This presence detector is a DALI-2 secondary and BMS detector that extends the detection range of a DALI-2 master detector or can be part of a DALI-2 BMS system. If the detector is used as a secondary detector and connected to a DALI bus controlled by a DALI-2 master detector, it will start communicating with this master detector without further commissioning. If it is connected to the DALI bus of a BMS system, the detector needs to be commissioned with the BMS software. The detector settings can be modified using the Niko detector tool app and 2-way Bluetooth® communication. The SnapFit mounting system guarantees fast and stable installation. The detector is prewired with a 2 m cable and a 5-pole female connector that is unique, which helps to avoid installation errors and save time.

This P46 detector with one cable is suitable for all DALI-2 installations. It can be used to extend the detection range for DALI-2 P47 or P48 master detectors or in combination with a DALI-2 BMS system.

Colour: white

Compatible secondary detectors:

Compatible master detectors: 353-651321-1, 353-651421-1, 353-651421-2, 353-751321-1, 353-751421-1, 353-751421-2

Compatible controls:

Detection range

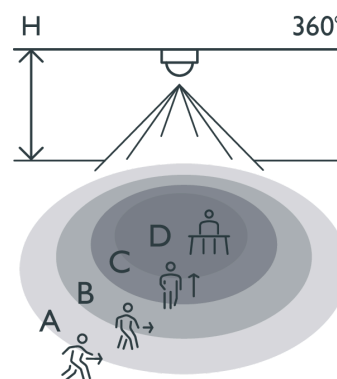

H	A Walking	B Across	C Towards	D Presence
2.5 m	ø 32 m	ø 28 m	ø 10 m	ø 8 m
3.0 m	ø 37 m	ø 30 m	ø 8 m	ø 5 m
3.5 m	ø 48 m	ø 42 m	ø 8 m	ø 6 m

Measured according to EN/IEC63180



This article is protected by at least one patent (or patent application). For more info on patents, see www.niko.eu/innovation.

- Easy installation thanks to the direct connection to the DALI bus
- Communication with the master or BMS system via the DALI bus
- Power supply via the DALI bus
- SnapFit mounting bracket for easy and stable mounting in all types of suspended ceilings with or without removable tiles
- Quick cabling using screwless and easily accessible plug-in terminals
- Screwless strain relief and screwless installation of cable cover
- User-friendly app for settings (iOS/Android) or BMS software
- 2-way Bluetooth® communication ensures quick modification of settings and live feedback in the app
- Fitted with three PIR segments, each covering 120°
- Pre-configured functions:
 - Settings and configuration can be locked with a PIN code

Technical features

attribute.compatiblemasterdetectors	353-651321-1, 353-651421-1, 353-651421-2, 353-751321-1, 353-751421-1, 353-751421-2
Configuration	secondary - BMS
Input voltage	30 Vdc via DALI-bus
Detector output	DALI-2
Maximum current consumption	28.1 mA
Nominal current consumption (12 V, 25°C), Bluetooth® enabled	8.1 mA
Nominal current consumption (12 V, 25°C), Bluetooth® disabled	5 mA
Maximum startup time DALI	<1,200 ms
Maximum PIR detection startup time	70 sec
Maximum MCB rating	16 A (limited by national installation rules)
Detection angle	360 °
Detection range (PIR)	ø 37 m from a height of 3 m
Minimum ambient temperature	-25 °C
Maximum ambient temperature	+40 °C
Mounting method	flush-mounting (SnapFit)
Mounting height	2 m – 3.5 m
Colour	white
Colour RAL (approximately)	9010
Dimensions visible (HxWxD)	100 mm x 100 mm
Dimensions (HxWxD)	120 mm x 120 mm x 99.1 mm
Maximum range Bluetooth® (free field, depending on the device)	50 m
Operating frequency	2.4 GHz
Maximum radio frequency power	-2 dBm
Protection degree standalone	IP20
Impact resistance	IK04
Modification of settings	Niko detector tool app (iOS-Android) and 2-way Bluetooth® communication - BMS software
Halogen-free	yes

Accessories

353-999879	Lens cover for P4XLR, M4XLR and M4XHC detectors transparent (5 pieces)
353-991992	Deco ring for flush-mounted P4XLR and M4XLR detectors, black
353-991901	Spring clips for flush-mounted P4XMR, P4XLR, M4XMR and M4XLR detectors (SnapFit)

Dimensions

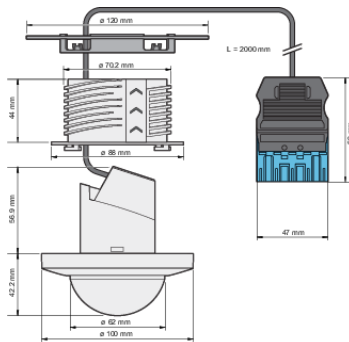

Wiring diagram

