

Data Sheet | Item Number: 771-8965/007-202

pre-assembled interconnecting cable; Eca; Distribution connector with phase selection/plug; 5-pole; Cod. A; H05VV-F 5G 2.5 mm²; 2 m; 2,50 mm²; white

<https://www.wago.com/771-8965/007-202>

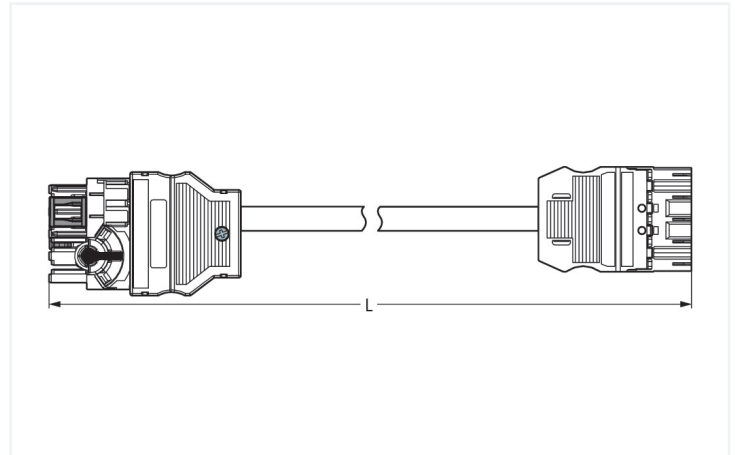

Color: ■ white

Similar to illustration

Dimensions in mm

Cable assembly WINSTA® MIDI with protection type IP20

For signal and power transmission: The WINSTA® MIDI cable assembly 5-pole. Whether on PCBs, in control cabinets or for connecting lights – pluggable installation connectors from WAGO allow you to establish connections according to a huge variety of requirements in next to no time. The coding options reduce installation errors, allowing fast, maintenance-free wiring of all components. The pluggable installation connector is protected against ingress by solid objects in accordance with protection type IP20 (When mated: IP2xC (These compact connectors are not designed for use in open, easily accessible areas!)). Thanks to the color coding and mechanical A coding of WINSTA® MIDI pluggable installation connectors, you can clearly distinguish different circuits. This pluggable installation connector is used for electrical currents up to 20 A. Thus the product is especially suitable for high power loads. The WINSTA® MIDI Pluggable Connection System with Push-in CAGE CLAMP® spring pressure connection technology facilitates safe electrification. Thanks to the integrated test slot, it is possible to check connections even when they are plugged in. This saves time, labor, and money. According to the European CPR, the fire class of the cables used for construction is critical for the safety of buildings, too. For buildings with medium-level safety requirements, cable assemblies with fire class E are suitable.

Pluggable connections instead of screw connections – cable assemblies from WAGO

A distribution connector with phase selection and a plug are available. The WINSTA® Pluggable Connection System is ideally tailored to the strict requirements of building installation. It makes electrical installation pluggable, and therefore more efficient, more reliable, and error-free. Using this pre-assembled system reduces assembly times and errors during installation at the construction site. Take advantage of the pluggable version of our maintenance-free spring pressure connection technology too! Plan your installation with with strain relief hosting from WAGO.

- protection against mismatching eliminates errors
- pre-assembled versions
- with A coding for a great number of applications
- custom-engineered solutions
- fast, secure installation

Notes

Note Cables with a different fire class can be found in the eShop.

Electrical data

Ratings per	IEC/EN 60664-1			General information	
Overvoltage category	III	III	II	Note on contact resistance	approx. 1 mΩ of contact resistance approx. 0.25 mΩ contact transition plug/ socket
Pollution degree	3	2	2		
Nominal voltage	400 V	-	-		
Rated impulse withstand voltage	6 kV	-	-		
Rated current	20 A	-	-		

Connection Data

Total number of potentials	5	Connection 1	
		Pole number	5
		Wire cross-section	2.5 mm ²
		Connection type	Distribution connector with phase selection - Plug

Connection 2

Pole number 3

Physical data

Pin spacing	10 mm / 0.394 inches
Width	54.6 mm / 2.15 inches
Height	43.8 mm / 1.724 inches
Total length	2 m

Mechanical data

Use	General mains applications
Coding	A
Variable coding	Yes
Marking	N ⊕ L1 L2 L3
Potential marking	N ⊕ L1 L2 L3
Mating force of a plug-in connection	approx. 20 ... 70 N (depending on pole number)
Retention force of a plug-in connection	when locked: > 80N
Unmating force of a plug-in connection	when unlocked: approx. 20 ... 70 N (depending on pole number)
Number of mating cycles	200, without resistive load
Connection type	Distribution connector with phase selection - Plug
Type of pre-assembled cable	Interconnecting cable
Cable type	H05VV-F 5G2.5
Protection type	IP20; When mated: IP2xC (These compact connectors are not designed for use in open, easily accessible areas!)

Plug-in connection

Mismating protection	Yes
Note on mismating protection	All WINSTA® components are 100% protected against mismating when: a.) plugging different numbers of poles b.) plugging while rotated 180 c.) plugging while laterally staggered d.) plugging one pole
Locking lever	Can be retrofitted
Locking of plug-in connection	Locking lever
Note on locking system	All connectors for mounted installations (snap-in versions for lighting fixtures or devices, all types of PCB and distribution connectors) are factory-equipped with locking levers to ensure plugs and sockets are securely locked. Additional locking levers are only required for flying leads (plug/socket).

Material data

Note (material data)	Information on material specifications can be found here
Color	white
Insulation material (main housing)	Polyamide (PA66)
Fire class per EN 50575	E _{ca}
Contact material	Copper or copper alloy; surface-treated
Contact Plating	Tin
Fire load	61.68 MJ
Connector color	white
Strain relief color	white
Sheathed cable color	white
Printing color of sheathed cable	black
Halogen-free	No
Silicon-free	Yes
Sheath material	PVC
Rubber cable	No
Weight	552.9 g

Environmental requirements

Processing temperature	-5 ... +40 °C
Continuous operating temperature	-35 ... +85 °C
Note on continuous operating temperature	Cable for temperatures ≤ 70 °C (including halogen-free) Insulating parts for temperatures ≤ 105 °C

Commercial data

PU (SPU)	1 pcs
Packaging type	unpacked
Country of origin	PL
GTIN	4045454559595
Customs tariff number	85444290900

Product Classification

UNSPSC	26121629
eCl@ss 10.0	27-44-06-04
eCl@ss 9.0	27-44-06-04
ETIM 9.0	EC002587
ETIM 10.0	EC002587
ECCN	NO US CLASSIFICATION

Environmental Product Compliance

RoHS Compliance Status	Compliant, No Exemption
------------------------	-------------------------

Approvals / Certificates

General approvals **Declarations of conformity and manufacturer's declarations**



Approval	Standard	Certificate Name
CCA DEKRA Certification B.V.	EN 61535	NTR NL-7972
KEMA/KEUR DEKRA Certification B.V.	EN 61535	71-123834

Approval	Standard	Certificate Name
EU-Declaration of Conformity WAGO GmbH & Co. KG	-	-
UK-Declaration of Conformity WAGO GmbH & Co. KG	-	-

Downloads

Environmental Product Compliance

Compliance Search

Environmental Product Compliance 771-8965/007-202	↓
--	---

Documentation

Bid Text

771-8965/007-202	19.02.2019	xml 2.96 KB	↓
771-8965/007-202	12.03.2015	doc 25.00 KB	↓

CAD/CAE-Data

CAE data

EPLAN Data Portal 771-8965/007-202	↓
WSCAD Universe 771-8965/007-202	↓

1 Compatible Products

1.1 Required Accessories

1.1.1 Locking system

1.1.1.1 Locking system



Item No.: 770-101

Locking lever; for flying leads; for manual operation; black

Item No.: 770-121

Locking lever; for flying leads; for manual operation; white

Item No.: 770-111

Locking lever; for flying leads; for tool operation; black

Item No.: 770-131

Locking lever; for flying leads; for tool operation; white

1.2 Optional Accessories

1.2.1 Cover

1.2.1.1 Cover



Item No.: 770-201

Lockout cap; 12-pole, separable; for sockets; Plastic; black

Item No.: 770-221

Lockout cap; 12-pole, separable; for sockets; Plastic; white

Item No.: 770-360

Lockout cap; for plugs; 5-pole; separable; yellow

Item No.: 897-2005

Protective cap; Type4; for sockets and plugs; PVC; red

1.2.2 Installation

1.2.2.1 Mounting accessories



Item No.: 770-310

Mounting carrier; 2- to 5-pole; for flying leads; black

1.2.3 Marking

1.2.3.1 Marker



Item No.: 770-450/000-006

Marker card; Plastic; blue

Item No.: 770-450/000-001

Marker card; Plastic; green

Item No.: 770-450/000-012

Marker card; Plastic; orange

Item No.: 770-450/000-005

Marker card; Plastic; red



Item No.: 770-450

Marker card; Plastic; white

Item No.: 770-450/000-002

Marker card; Plastic; yellow

1.2.3.2 Marking strip



Item No.: 210-334

Marking strips; as a DIN A4 sheet; Strip width 5 mm; Strip length 182 mm; plain; Self-adhesive; white

Installation Notes



Lift jumper out of delivery position (L2) using a screwdriver and move it into the desired position.



Push down jumper in its new position (picture shows L3).

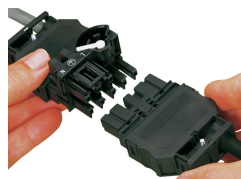

The 5-pole energy circuit can be extended using pluggable cable assemblies.



Plugging a 3-pole tap-off cable.