

## Data Sheet | Item Number: 771-8965/017-201

pre-assembled interconnecting cable; Eca; Distribution connector with phase selection/plug; 5-pole; Cod. A; H05Z1Z1-F 5G 2.5 mm<sup>2</sup>; 2 m; 2,50 mm<sup>2</sup>; black

<https://www.wago.com/771-8965/017-201>



Color: ■ black

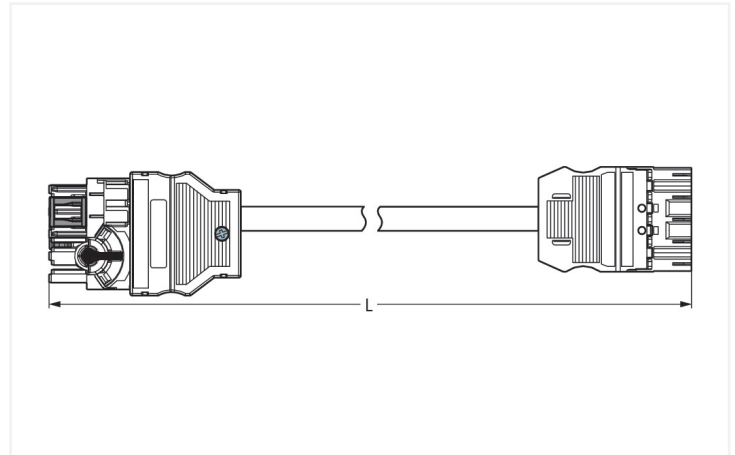

Dimensions in mm

### Cable assembly WINSTA® MIDI with strain relief

The WINSTA® MIDI cable assembly rated current 20 A is the pluggable solution for your use in control cabinets, on PCBs or for lighting connections. Whether on PCBs, in control cabinets or for connecting lights – pluggable installation connectors from WAGO allow you to make connections according to various requirements in next to no time. The coding options reduce installation errors, allowing fast, maintenance-free wiring of all components. The pluggable installation connector is protected in accordance with protection type IP20 (When mated: IP2xC (These compact connectors are not designed for use in open, easily accessible areas!)). That results in the fact that users' fingers will never come into contact with live elements. The WINSTA® MIDI pluggable installation connector with A coding in white or black is normally used for general mains applications in power distribution. This pluggable installation connector is designed for a voltage load of up to 20 A. As a result, it can also be used for high power loads. WINSTA® MIDI with Push-in CAGE CLAMP® spring pressure connection technology is used in can be found in a variety of projects you can use for quick, easy and maximally flexible installation. This product meets all the relevant safety requirements of fire class E; as a result it can be used in domains where fire safety is relevant. In the production of this cable assembly, we eliminated the use of halogen. This is an important contribution to environmental protection.

### Fast, error-free assembly thanks to cable assemblies from WAGO

The cable assembly is equipped with a distribution connector with phase selection and a plug. WINSTA® is the pluggable connection system that is optimally tailored to the strict requirements of electrical installation. It allows fast, secure and, above all, error-free installation of components and cables. Now you can also reduce installation costs without compromising safety and quality: with fire class E eliminates the need for servicing and prevents unnecessary downtime.

- effective protection against mismatching
- pre-assembled versions
- suitable for any application
- ready for immediate use
- quick replacement of defective units during ongoing operation

## Notes

Note Cables with a different fire class can be found in the eShop.

## Electrical data

Ratings per	IEC/EN 60664-1			General information	
Overvoltage category	III	III	II	Note on contact resistance	approx. 1 mΩ of contact resistance approx. 0.25 mΩ contact transition plug/ socket
Pollution degree	3	2	2		
Nominal voltage	400 V	-	-		
Rated impulse withstand voltage	6 kV	-	-		
Rated current	20 A	-	-		

## Connection Data

Total number of potentials	5	<b>Connection 1</b>	
		Pole number	5
		Wire cross-section	2.5 mm <sup>2</sup>
		Connection type	Distribution connector with phase selection - Plug

## Connection 2

Pole number	3
-------------	---

## Physical data

Pin spacing	10 mm / 0.394 inches
Width	54.6 mm / 2.15 inches
Height	43.8 mm / 1.724 inches
Total length	2 m

## Mechanical data

Use	General mains applications
Coding	A
Variable coding	Yes
Marking	N ⊕ L1 L2 L3
Potential marking	N ⊕ L1 L2 L3
Mating force of a plug-in connection	approx. 20 ... 70 N (depending on pole number)
Retention force of a plug-in connection	when locked: > 80N
Unmating force of a plug-in connection	when unlocked: approx. 20 ... 70 N (depending on pole number)
Number of mating cycles	200, without resistive load
Connection type	Distribution connector with phase selection - Plug
Type of pre-assembled cable	Interconnecting cable
Cable type	H05Z1Z1-F 5G2.5
Protection type	IP20; When mated: IP2xC (These compact connectors are not designed for use in open, easily accessible areas!)

### Plug-in connection

Mismating protection	Yes
Note on mismating protection	All WINSTA® components are 100% protected against mismating when: a.) plugging different numbers of poles b.) plugging while rotated 180 c.) plugging while laterally staggered d.) plugging one pole
Locking lever	Can be retrofitted
Locking of plug-in connection	Locking lever
Note on locking system	All connectors for mounted installations (snap-in versions for lighting fixtures or devices, all types of PCB and distribution connectors) are factory-equipped with locking levers to ensure plugs and sockets are securely locked. Additional locking levers are only required for flying leads (plug/socket).

### Material data

Note (material data)	<a href="#">Information on material specifications can be found here</a>
Color	black
Insulation material (main housing)	Polyamide (PA66)
Fire class per EN 50575	E <sub>ca</sub>
Contact material	Copper or copper alloy; surface-treated
Contact Plating	Tin
Fire load	61.587 MJ
Connector color	black
Strain relief color	black
Sheathed cable color	black
Printing color of sheathed cable	white
Halogen-free	Yes
Silicon-free	Yes
Sheath material	Halogen-free
Rubber cable	No
Weight	534.2 g

### Environmental requirements

Processing temperature	-5 ... +40 °C
Continuous operating temperature	-35 ... +85 °C
Note on continuous operating temperature	Cable for temperatures ≤ 70 °C (including halogen-free) Insulating parts for temperatures ≤ 105 °C

### Commercial data

PU (SPU)	1 pcs
Packaging type	unpacked
Country of origin	DE
GTIN	4045454558611
Customs tariff number	85444290900

### Product Classification

UNSPSC	26121629
eCl@ss 10.0	27-44-06-04
eCl@ss 9.0	27-44-06-04
ETIM 9.0	EC002587
ETIM 10.0	EC002587
ECCN	NO US CLASSIFICATION

**Environmental Product Compliance**

RoHS Compliance Status	Compliant, No Exemption
------------------------	-------------------------

**Approvals / Certificates**

**General approvals** **Declarations of conformity and manufacturer's declarations**



Approval	Standard	Certificate Name
CCA DEKRA Certification B.V.	EN 61535	NTR NL-7972
KEMA/KEUR DEKRA Certification B.V.	EN 61535	71-123834

Approval	Standard	Certificate Name
EU-Declaration of Confor- mity WAGO GmbH & Co. KG	-	-
UK-Declaration of Confor- mity WAGO GmbH & Co. KG	-	-

**Downloads**

**Environmental Product Compliance**

**Compliance Search**

Environmental Product Compliance 771-8965/017-201	↓
--	---

**Documentation**

**Bid Text**

Item Number	Date	File Type / Size	Action
771-8965/017-201	19.02.2019	xml 2.96 KB	↓
771-8965/017-201	12.03.2015	doc 25.00 KB	↓

**CAD/CAE-Data**

**CAE data**

EPLAN Data Portal 771-8965/017-201	↓
WSCAD Universe 771-8965/017-201	↓

## 1 Compatible Products

### 1.1 Required Accessories

#### 1.1.1 Locking system

##### 1.1.1.1 Locking system



**Item No.: 770-101**

Locking lever; for flying leads; for manual operation; black

**Item No.: 770-121**

Locking lever; for flying leads; for manual operation; white

**Item No.: 770-111**

Locking lever; for flying leads; for tool operation; black

**Item No.: 770-131**

Locking lever; for flying leads; for tool operation; white

### 1.2 Optional Accessories

#### 1.2.1 Cover

##### 1.2.1.1 Cover



**Item No.: 770-201**

Lockout cap; 12-pole, separable; for sockets; Plastic; black

**Item No.: 770-221**

Lockout cap; 12-pole, separable; for sockets; Plastic; white

**Item No.: 770-360**

Lockout cap; for plugs; 5-pole; separable; yellow

**Item No.: 897-2005**

Protective cap; Type4; for sockets and plugs; PVC; red

#### 1.2.2 Installation

##### 1.2.2.1 Mounting accessories



**Item No.: 770-310**

Mounting carrier; 2- to 5-pole; for flying leads; black

#### 1.2.3 Marking

##### 1.2.3.1 Marker



**Item No.: 770-450/000-006**

Marker card; Plastic; blue

**Item No.: 770-450/000-001**

Marker card; Plastic; green

**Item No.: 770-450/000-012**

Marker card; Plastic; orange

**Item No.: 770-450/000-005**

Marker card; Plastic; red



**Item No.: 770-450**

Marker card; Plastic; white

**Item No.: 770-450/000-002**

Marker card; Plastic; yellow

##### 1.2.3.2 Marking strip



**Item No.: 210-334**

Marking strips; as a DIN A4 sheet; Strip width 5 mm; Strip length 182 mm; plain; Self-adhesive; white

## Installation Notes



Lift jumper out of delivery position (L2) using a screwdriver and move it into the desired position.



Push down jumper in its new position (picture shows L3).

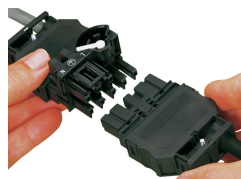

The 5-pole energy circuit can be extended using pluggable cable assemblies.



Plugging a 3-pole tap-off cable.