

Duct sensor CO₂ / Humidity / Temperature

For measuring CO₂, with integrated temperature and humidity sensor. Dual channel CO₂ technology. With BACnet MS/TP communication and integrated 0...10 V outputs. IP65 / NEMA 4X rated enclosure.

Type Overview

Type	Communication	Output signal active CO ₂	Output signal active temperature
22DTM-16	BACnet MS/TP	0...5 V, 0...10 V	0...5 V, 0...10 V

Technical data

Electrical data	Nominal voltage	AC/DC 24 V	
	Nominal voltage range	AC 19...29 V / DC 15...35 V	
	Power consumption AC	4.3 VA	
	Power consumption DC	2.3 W	
	Electrical connection	Pluggable spring loaded terminal block max. 2.5 mm ²	
	Cable entry	Cable gland with strain relief 2x ø6 mm	
Data bus communication	Communication	BACnet MS/TP	
	Number of nodes	BACnet see interface description	
Functional data	Application	Air	
	Voltage output	2 x 0...5 V, 0...10 V, min. resistance 10 kΩ	
	Output signal active note	Output 0...5/10 V with Jumper adjustable	
Measuring data	Measured values	CO ₂ Relative humidity Absolute humidity Dew point Enthalpies Temperature	
	Specification CO₂	Sensing element technology	NDIR (non dispersive infrared) dual channel
		Measuring range	Default setting: 0...2000 ppm With A-22G-A05: 0...5000 ppm
		Accuracy	±(50 ppm + 3% of measured value)
		Long term stability	±50 ppm p.a.
Calibration		Self-calibration Dual channel	
	Time constant τ (63%) in the air duct	Typical 33 s @ 1 m/s	

Technical data

Specification Temperature	Measuring range	Adjustable via BACnet 0...50°C [32...122°F] (default setting) Attention: max. measuring temperature is restricted by max. fluid temperature (see Safety data)
	Accuracy temperature active	±0.3°C @ 25°C [±0.5°F @ 77°F]
	Long term stability	±0.05°C p.a. @ 21°C [±0.09°F p.a. @ 70°F]
	Calibration	Self-calibration Dual channel
	Time constant τ (63%) in the air duct	Typical 125 s @ 3 m/s
Specification Humidity	Sensing element technology	with stainless steel wire mesh filter
	Measuring range	Adjustable via BACnet Default setting: 0...100% RH
	Measuring range absolute humidity	Adjustable via BACnet Default setting: 0...50 g/m ³
	Measuring range enthalpy	Adjustable via BACnet Default setting: 0...85 kJ/kg
	Measuring range dew point	Adjustable via BACnet Default setting: 0...50°C [-30...120°F]
	Accuracy	±2% between 0...80% RH @ 25°C
	Long term stability	±0.3% RH p.a. @ 21°C @ 50% RH
	Calibration	Self-calibration Dual channel
	Time constant τ (63%) in the air duct	Typical 10 s @ 3 m/s
Safety data	Protection class IEC/EN	III, Safety Extra-Low Voltage (SELV)
	Power source UL	Class 2 Supply
	Degree of protection IEC/EN	IP65
	Degree of protection NEMA/UL	NEMA 4X
	Enclosure	UL Enclosure Type 4X
	EU Conformity	CE Marking
	Certification IEC/EN	IEC/EN 60730-1
	Quality Standard	ISO 9001
	UL Approval	cULus acc. to UL60730-1A/-2-9/-2-13, CAN/CSA E60730-1/-2-9
	Type of action	Type 1
	Rated impulse voltage supply	0.8 kV
	Pollution degree	3
	Ambient humidity	Max. 95% RH, non-condensing
	Ambient temperature	0...50°C [32...122°F]
	Fluid humidity	Max. 95% RH, non-condensing
	Fluid temperature	0...50°C [32...122°F]
	Operating condition airflow	min. 0.3 m/s max. 12 m/s
Materials	Cable gland	PA6, black
	Housing	Cover: PC, orange Bottom: PC, orange Seal: NBR70, black UV resistant
	Probe material	PA6, black

Safety notes



This device has been designed for use in stationary heating, ventilation and air-conditioning systems and must not be used outside the specified field of application. Unauthorised modifications are prohibited. The product must not be used in relation with any equipment that in case of a failure may threaten humans, animals or assets.

Ensure all power is disconnected before installing. Do not connect to live/operating equipment.

Only authorised specialists may carry out installation. All applicable legal or institutional installation regulations must be complied with during installation.

The device contains electrical and electronic components and must not be disposed of as household refuse. All locally valid regulations and requirements must be observed.

Remarks

General remarks concerning sensors

Sensing devices with a transducer should always be operated in the middle of the measuring range to avoid deviations at the measuring end points. The ambient temperature of transducer electronics should be kept constant. The transducers must be operated at a constant supply voltage (± 0.2 V). When switching the supply voltage on/off, onsite power surges must be avoided.

Remark: Occurring draft leads to a better carrying-off of dissipative power at the sensor. Thus temporally limited fluctuations might occur upon temperature measurement.

Build-up of self-heating by electrical dissipative power

Temperature sensors with electronic components always have a dissipative power which affects the temperature measurement of the ambient air. The dissipation in active temperature sensors shows a linear increase with rising operating voltage. The dissipative power should be taken into account when measuring temperature.

In case of a fixed operating voltage (± 0.2 V), this is normally done by adding or reducing a constant offset value. As Belimo transducers work with a variable operating voltage, for reasons of production engineering only one operating voltage can be taken into consideration. Transducers 0...10 V / 4...20 mA have a standard setting at an operating voltage of DC 24 V. This means that at this voltage, the expected measuring error of the output signal will be the least. For other operating voltages, the offset error will be increased by a changing power loss of the sensor electronics.

If a readjustment directly at the active sensor should be necessary during later operation, this can be done with the following adjustment methods.

- For sensors with NFC or dongle with the corresponding Belimo app
- For sensors with a trimming potentiometer on the sensor board
- For bus sensors via bus interface with a corresponding software variable

Requirements to be met by the medium

To ensure the ongoing and optimal functioning of the sensor, it is imperative that the air being measured is free of dust or other contaminants that could accumulate on the sensor element.

Application notice for humidity sensors

The humidity sensor is extremely sensitive. Touching the sensor element or exposing it to aggressive substances like chlorine, ozone, ammonia, hydrogen peroxide or ethanol (i.e. as a cleaning agent) may affect the measurement accuracy.

Long term operation outside the recommended conditions (5...50°C and 20...80% RH) can result in a temporary offset. After returning into the recommended range, this effect disappears.

Information self-calibration feature CO₂

All CO₂ sensors are subject to drift caused by the aging process of the components, resulting in regular re-calibration or replacement of units. However, the dual channel technology integrates automatic self-calibration technology vs. commonly used ABC-Logic sensors. Dual channel self-calibration technology is ideally suited for applications operating 24/7 hours such as those in hospitals or other commercial applications. Manual calibration is not required.

Parts included

Description	Type
Mounting flange for duct sensor 19.5 mm, up to max. 120°C [248°F], Plastic	A-22D-A35
Cable Gland with strain relief ø6...8 mm	

Accessories

Optional accessories	Description	Type
	Replacement filter sensor probe tip, wire mesh, Stainless steel	A-22D-A06
	Connection adapter flex conduit, M20x1.5, for cable gland 1x 6 mm, Multipack 10 pcs.	A-22G-A01.1
	Connection adapter flex conduit, M20, for cable gland 2x 6 mm, Multipack 10 pcs.	A-22G-A02.1
	Mounting plate L housing	A-22D-A10

Tools	Description	Type
	Belimo Duct Sensor Assistant App	Belimo Duct Sensor Assistant App
	Bluetooth dongle for Belimo Duct Sensor Assistant App	A-22G-A05
	* Bluetooth dongle A-22G-A05	
	Certified and available in North America, European Union, EFTA States and UK.	

Service

Tools connection This sensor can be operated and parametrised using the Belimo Duct Sensor Assistant App. When using the Belimo Duct Sensor Assistant App, the bluetooth dongle is required to enable communication between the app and the Belimo sensor.

For the standard operation and parametrisation of the sensor the bluetooth dongle and the Belimo Duct Sensor Assistant App are not needed. The sensor will arrive pre-configured with the factory default settings shown above.

Requirement:

- Bluetooth dongle (Belimo Part No: A-22G-A05)
- Bluetooth-capable smartphone
- Belimo Duct Sensor Assistant App (Google Play & Apple App Store)

Procedure:

- Plug the Bluetooth dongle into the sensor via the Micro-USB connector or by means of the interface PCB
- Connect Bluetooth-capable smartphone with Bluetooth dongle
- Select parametrisation in the Belimo Duct Sensor Assistant App

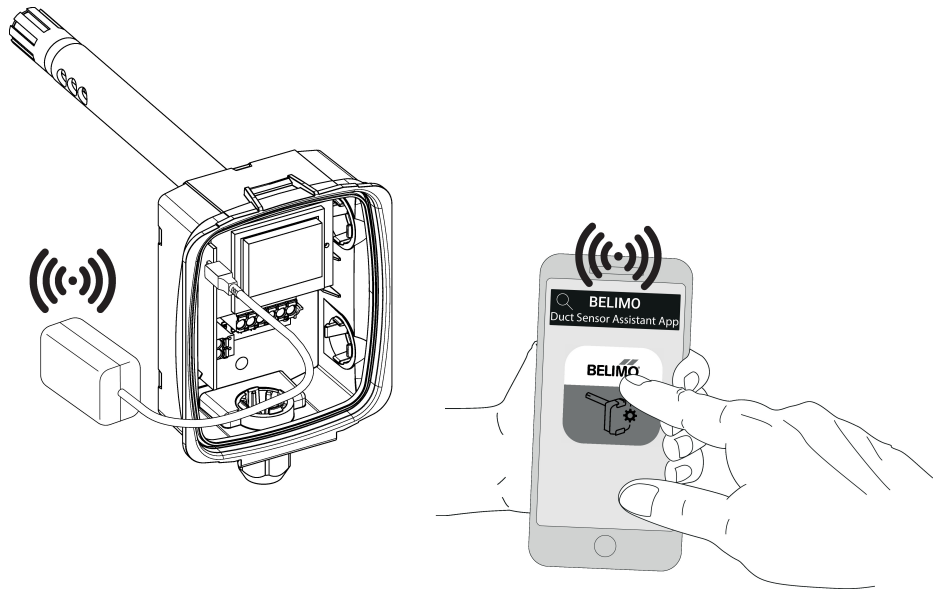

Wiring diagram



Notes

Supply from isolating transformer.

The wiring of the line for BACnet (MS/TP) has to be carried out in accordance with applicable RS-485 regulations.

BACnet GND: Supply and communication are not galvanically isolated. Connect earth signal of the devices with one another.

Wiring diagram

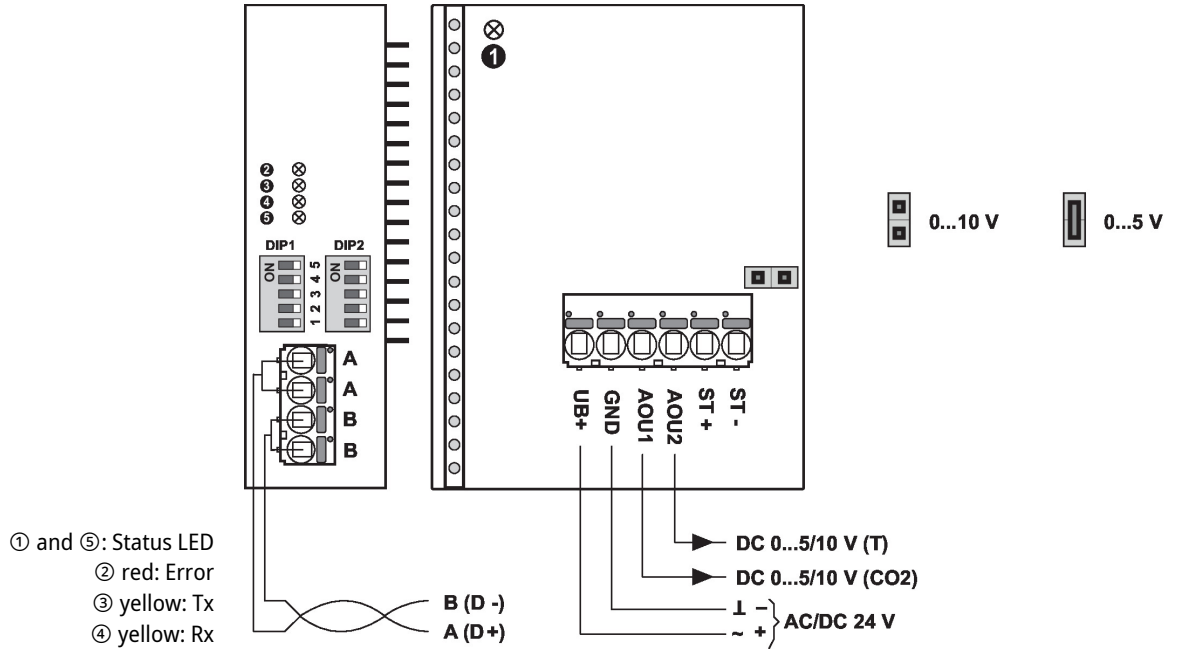

Detailed documentation

The separate document, BACnet PICS, informs about the PICS, MAC addressing and bus termination (DIP1 & DIP2).

Wiring RS-485 BACnet MS/TP

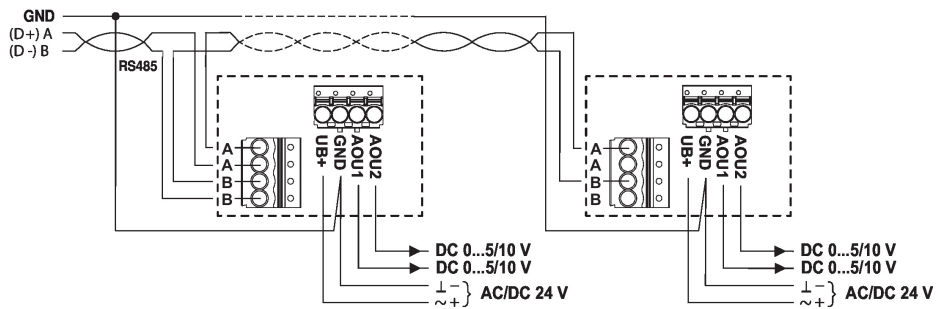

Dimensions

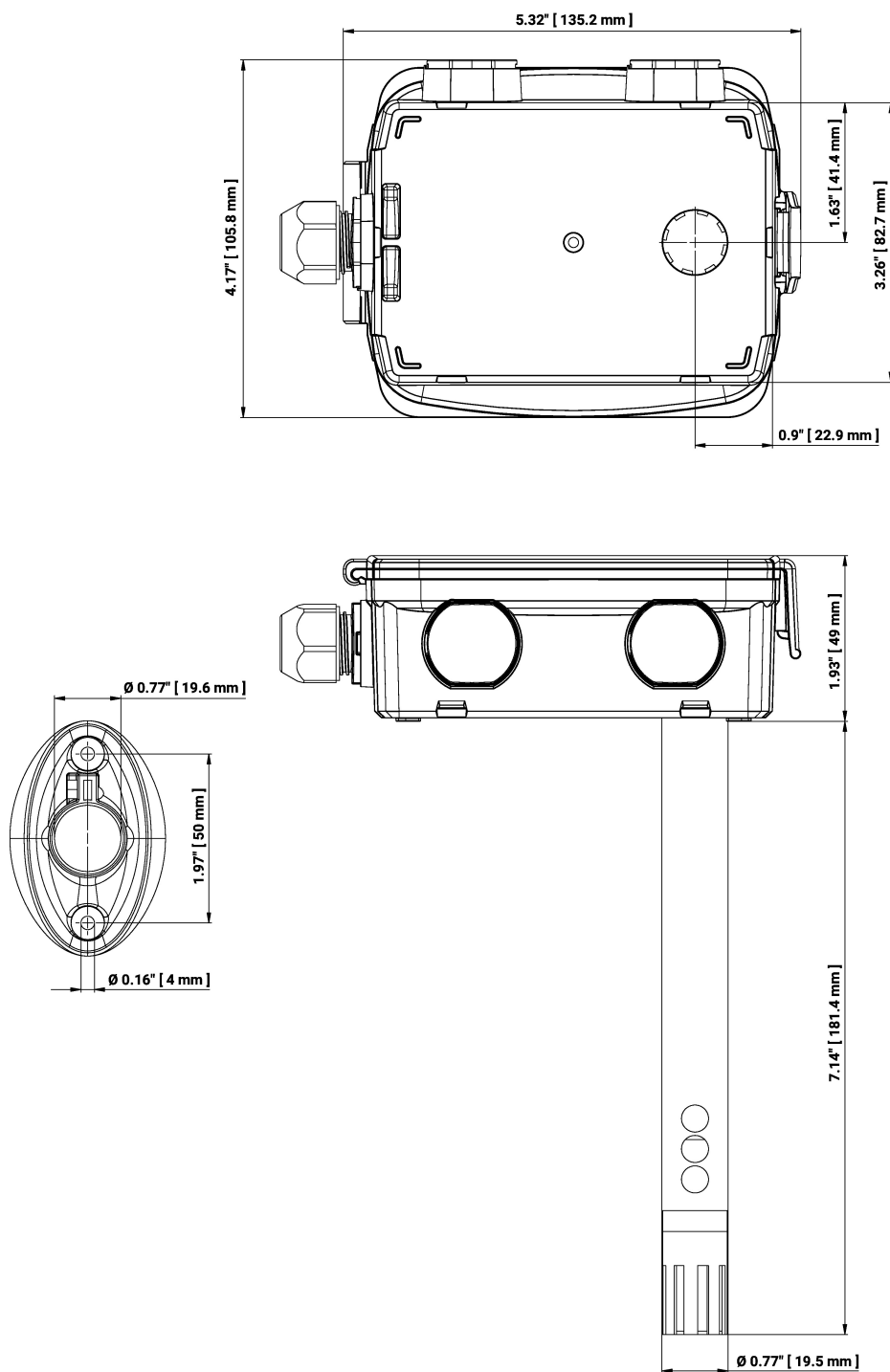

Type	Probe length	Weight
22DTM-16	180 mm	0.28 kg

Further documentation

- BACnet Interface description
- Installation instructions