

## Data Sheet | Item Number: 771-8965/017-202

pre-assembled interconnecting cable; Eca; Distribution connector with phase selection/plug; 5-pole; Cod. A; H05Z1Z1-F 5G 2.5 mm<sup>2</sup>; 2 m; 2,50 mm<sup>2</sup>; white

<https://www.wago.com/771-8965/017-202>

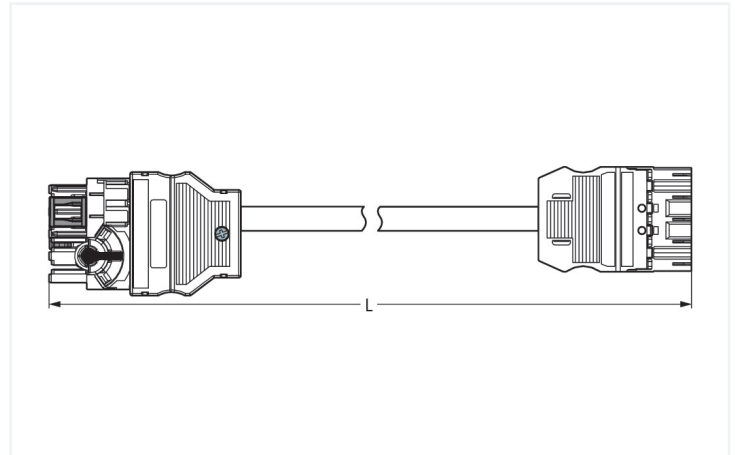

Color: ■ white

Similar to illustration

Dimensions in mm

### Cable assembly WINSTA® MIDI with strain relief

For signal and power transmission: The WINSTA® MIDI cable assembly 5-pole. Our pluggable installation connectors with spring pressure connection technology function entirely without screw connections. They allow fast, efficient, error-free installation in a large number of possible uses. The coding options reduce installation errors, allowing fast, secure wiring of all components. The pluggable installation connector offers protection against contact with live components in accordance with protection type IP20 (When mated: IP2xC (These compact connectors are not designed for use in open, easily accessible areas!)). The WINSTA® MIDI pluggable installation connector with A coding in white or black is normally used for general mains applications in power distribution. This pluggable installation connector can be employed for a current load of up to 20 A. As a result, it can also be used for high power loads. WINSTA® MIDI with Push-in CAGE CLAMP® spring pressure connection technology is used in a broad range of individual products you can use for quick, easy, secure, tailored installation. Building safety must be ensured at all times, even after the electrical installation stage. The mandatory safety requirements in connection with EU CPR are fully satisfied by this product through fire class E. The cable assembly is halogen-free. This eliminates the addition of environmental pollutants during production. It also increases the fire class, since halogen-free materials are flame-resistant.

### Fast, secure pluggable connections – cable assemblies from WAGO

The cable is pre-assembled with a distribution connector with phase selection and a plug. The WINSTA® Pluggable Connection System is ideally tailored to the very strict requirements of building installation. It makes electrical installation pluggable, and therefore faster, more reliable, and error-free. Use of this pre-assembled system decreases time spent on assembly and errors during installation at the construction site. Now you can also cut installation costs without compromising safety and quality: with strain relief hosting reduces the need for servicing and prevents unnecessary downtime.

- protection against mismatching eliminates errors
- simple circuits
- with A coding for use in many general mains applications
- custom-engineered solutions
- quick replacement of defective units during ongoing operation

## Notes

Note Cables with a different fire class can be found in the eShop.

## Electrical data

Ratings per	IEC/EN 60664-1			General information	
Overvoltage category	III	III	II	Note on contact resistance	approx. 1 mΩ of contact resistance approx. 0.25 mΩ contact transition plug/ socket
Pollution degree	3	2	2		
Nominal voltage	400 V	-	-		
Rated impulse withstand voltage	6 kV	-	-		
Rated current	20 A	-	-		

## Connection Data

Total number of potentials	5	<b>Connection 1</b>	
		Pole number	5
		Wire cross-section	2.5 mm <sup>2</sup>
		Connection type	Distribution connector with phase selection - Plug

## Connection 2

Pole number 3

## Physical data

Pin spacing	10 mm / 0.394 inches
Width	54.6 mm / 2.15 inches
Height	43.8 mm / 1.724 inches
Total length	2 m

## Mechanical data

Use	General mains applications
Coding	A
Variable coding	Yes
Marking	N ⊕ L1 L2 L3
Potential marking	N ⊕ L1 L2 L3
Mating force of a plug-in connection	approx. 20 ... 70 N (depending on pole number)
Retention force of a plug-in connection	when locked: > 80N
Unmating force of a plug-in connection	when unlocked: approx. 20 ... 70 N (depending on pole number)
Number of mating cycles	200, without resistive load
Connection type	Distribution connector with phase selection - Plug
Type of pre-assembled cable	Interconnecting cable
Cable type	H05Z1Z1-F 5G2.5
Protection type	IP20; When mated: IP2xC (These compact connectors are not designed for use in open, easily accessible areas!)

### Plug-in connection

Mismating protection	Yes
Note on mismating protection	All WINSTA® components are 100% protected against mismating when: a.) plugging different numbers of poles b.) plugging while rotated 180 c.) plugging while laterally staggered d.) plugging one pole
Locking lever	Can be retrofitted
Locking of plug-in connection	Locking lever
Note on locking system	All connectors for mounted installations (snap-in versions for lighting fixtures or devices, all types of PCB and distribution connectors) are factory-equipped with locking levers to ensure plugs and sockets are securely locked. Additional locking levers are only required for flying leads (plug/socket).

### Material data

Note (material data)	<a href="#">Information on material specifications can be found here</a>
Color	white
Insulation material (main housing)	Polyamide (PA66)
Fire class per EN 50575	E <sub>ca</sub>
Contact material	Copper or copper alloy; surface-treated
Contact Plating	Tin
Fire load	61.68 MJ
Connector color	white
Strain relief color	white
Sheathed cable color	white
Printing color of sheathed cable	black
Halogen-free	Yes
Silicon-free	Yes
Sheath material	Halogen-free
Rubber cable	No
Weight	532.7 g

### Environmental requirements

Processing temperature	-5 ... +40 °C
Continuous operating temperature	-35 ... +85 °C
Note on continuous operating temperature	Cable for temperatures ≤ 70 °C (including halogen-free) Insulating parts for temperatures ≤ 105 °C

### Commercial data

PU (SPU)	1 pcs
Packaging type	unpacked
Country of origin	DE
GTIN	4045454559656
Customs tariff number	85444290900

### Product Classification

UNSPSC	26121629
eCl@ss 10.0	27-44-06-04
eCl@ss 9.0	27-44-06-04
ETIM 9.0	EC002587
ETIM 10.0	EC002587
ECCN	NO US CLASSIFICATION

**Environmental Product Compliance**

RoHS Compliance Status	Compliant, No Exemption
------------------------	-------------------------

**Approvals / Certificates**

**General approvals** **Declarations of conformity and manufacturer's declarations**



Approval	Standard	Certificate Name
CCA DEKRA Certification B.V.	EN 61535	NTR NL-7972
KEMA/KEUR DEKRA Certification B.V.	EN 61535	71-123834

Approval	Standard	Certificate Name
EU-Declaration of Confor- mity WAGO GmbH & Co. KG	-	-
UK-Declaration of Confor- mity WAGO GmbH & Co. KG	-	-

**Downloads**

**Environmental Product Compliance**

**Compliance Search**

Environmental Product Compliance 771-8965/017-202	↓
--	---

**Documentation**

**Bid Text**

Item Number	Date	File Type	Size	Action
771-8965/017-202	19.02.2019	xml	2.96 KB	↓
771-8965/017-202	12.03.2015	doc	25.00 KB	↓

**CAD/CAE-Data**

**CAE data**

EPLAN Data Portal 771-8965/017-202	↓
WSCAD Universe 771-8965/017-202	↓

## 1 Compatible Products

### 1.1 Required Accessories

#### 1.1.1 Locking system

##### 1.1.1.1 Locking system



**Item No.: 770-101**

Locking lever; for flying leads; for manual operation; black

**Item No.: 770-121**

Locking lever; for flying leads; for manual operation; white

**Item No.: 770-111**

Locking lever; for flying leads; for tool operation; black

**Item No.: 770-131**

Locking lever; for flying leads; for tool operation; white

### 1.2 Optional Accessories

#### 1.2.1 Cover

##### 1.2.1.1 Cover



**Item No.: 770-201**

Lockout cap; 12-pole, separable; for sockets; Plastic; black

**Item No.: 770-221**

Lockout cap; 12-pole, separable; for sockets; Plastic; white

**Item No.: 770-360**

Lockout cap; for plugs; 5-pole; separable; yellow

**Item No.: 897-2005**

Protective cap; Type4; for sockets and plugs; PVC; red

#### 1.2.2 Installation

##### 1.2.2.1 Mounting accessories



**Item No.: 770-310**

Mounting carrier; 2- to 5-pole; for flying leads; black

#### 1.2.3 Marking

##### 1.2.3.1 Marker



**Item No.: 770-450/000-006**

Marker card; Plastic; blue

**Item No.: 770-450/000-001**

Marker card; Plastic; green

**Item No.: 770-450/000-012**

Marker card; Plastic; orange

**Item No.: 770-450/000-005**

Marker card; Plastic; red



**Item No.: 770-450**

Marker card; Plastic; white

**Item No.: 770-450/000-002**

Marker card; Plastic; yellow

##### 1.2.3.2 Marking strip



**Item No.: 210-334**

Marking strips; as a DIN A4 sheet; Strip width 5 mm; Strip length 182 mm; plain; Self-adhesive; white

## Installation Notes



Lift jumper out of delivery position (L2) using a screwdriver and move it into the desired position.



Push down jumper in its new position (picture shows L3).

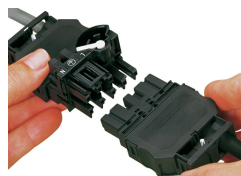

The 5-pole energy circuit can be extended using pluggable cable assemblies.



Plugging a 3-pole tap-off cable.