

## Data Sheet | Item Number: 891-8985/116-201

pre-assembled connecting cable; Eca; Socket/open-ended; 5-pole; Cod. I;  
H05Z1Z1-F 5G 1.5 mm<sup>2</sup>; 2 m; 1,50 mm<sup>2</sup>; blue

<https://www.wago.com/891-8985/116-201>

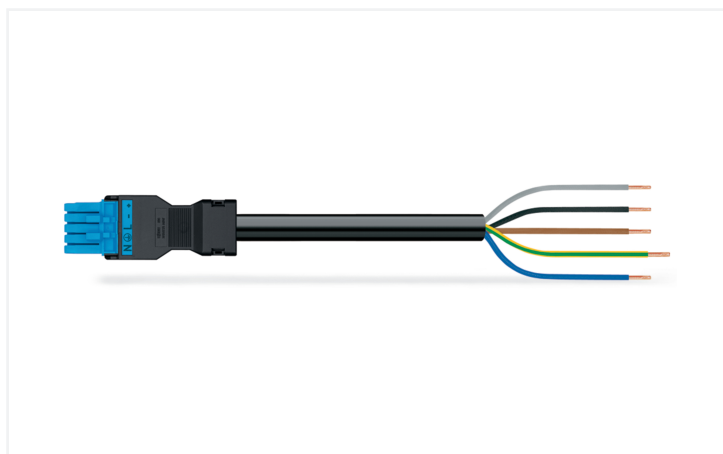

Color: ■ blue

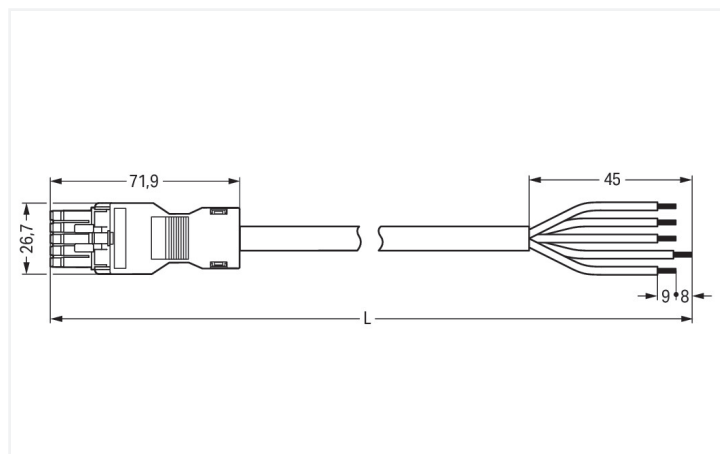

Dimensions in mm

### Cable assembly WINSTA® MINI I coding

The WINSTA® MINI cable assembly 5-pole provides the foundation for installation of solid and fine-stranded conductors. WAGO pluggable installation connectors can be used when requirements repeat or are planned on a specific pattern, for example for installing grid lighting or flush-mount lighting. The coding options reduce installation errors, allowing fast, maintenance-free wiring of all components. The pluggable installation connector offers protection against contact with wires or tools if they are smaller than 1 mm in accordance with protection type IP40. I coding in blue is used to identify WINSTA® MINI pluggable installation connectors, which are used primarily in automation of buildings for activating lighting. Thanks to its particularly small dimensions, our WINSTA® MINI Pluggable Connection System with Push-in CAGE CLAMP® spring pressure connection technology is specifically suitable in very tight spaces, i.e., for connections when very little room is available. This product meets all the relevant safety requirements of fire class E; therefore it can be used in domains where fire safety is relevant. Not using halogen additives in the production of this cable assembly significantly improves fire safety and reduces environmental contamination.

### Pluggable connections instead of screw connections – cable assemblies from WAGO

The cable assembly is provided with a socket and a free end. WINSTA® is the pluggable connection system that is optimally tailored to the strict requirements of electrical installation. It ensures error-free installation of cables and components, quickly and reliably. Choose durability and quality – with marking from WAGO makes the installation of electrical components visibly easier.

- effective protection against mismatching
- compact design for conductors with a cross-section up to 1.5 mm<sup>2</sup>
- for lighting management
- exact dimensions
- convenient installation and commissioning

### Notes

Note Cables with a different fire class can be found in the eShop.

## Electrical data

Ratings per	IEC/EN 60664-1		
Overvoltage category	III	III	II
Pollution degree	3	2	2
Nominal voltage	400 V	-	-
Rated impulse withstand voltage	6 kV	-	-
Rated current	16 A	-	-

## General information

Note on contact resistance	approx. 1 mΩ of contact resistance approx. 0.25 mΩ contact transition plug/ socket
----------------------------	--

## Connection Data

Total number of potentials	5
PE function	Preceding PE contact
Conductor preparation	ultrasonically tip-bonded

## Connection 1

Strip length	9 mm / 0.35 inches
Pole number	5
Wire cross-section	1.5 mm <sup>2</sup>
Strip length (outer insulation)	45 mm
Connection type	Socket - free end

## Physical data

Pin spacing	4.4 mm / 0.173 inches
Width	26.7 mm / 1.051 inches
Height	15.8 mm / 0.622 inches
Total length	2 m

## Mechanical data

Use	DALI, Lighting Management
Coding	I
Variable coding	No
Marking	N ⊕ L - +
Potential marking	N ⊕ L - +
Mating force of a plug-in connection	approx. 20 ... 70 N (depending on pole number)
Retention force of a plug-in connection	when locked: > 80N
Unmating force of a plug-in connection	when unlocked: approx. 20 ... 70 N (depending on pole number)
Number of mating cycles	200, without resistive load
Connection type	Socket - free end
Type of pre-assembled cable	Connecting cable
Cable type	H05Z1Z1-F 5G1.5
Protection type	IP40

## Plug-in connection

Mismating protection	Yes
Note on mismating protection	All WINSTA® components are 100% protected against mismating when: a.) plugging different numbers of poles b.) plugging while rotated 180 c.) plugging while laterally staggered d.) plugging one pole
Locking lever	Can be retrofitted
Locking of plug-in connection	Locking lever
Note on locking system	All connectors for mounted installations (snap-in versions for lighting fixtures or devices, all types of PCB and distribution connectors) are factory-equipped with locking levers to ensure plugs and sockets are securely locked. Additional locking levers are only required for flying leads (plug/socket).

### Material data

Note (material data)	<a href="#">Information on material specifications can be found here</a>
Color	blue
Insulation material (main housing)	Polyamide (PA66)
Fire class per EN 50575	E <sub>ca</sub>
Contact material	Copper or copper alloy; surface-treated
Contact Plating	Tin
Fire load	59.938 MJ
Connector color	blue
Strain relief color	black
Sheathed cable color	black
Printing color of sheathed cable	white
Halogen-free	Yes
Silicon-free	Yes
Sheath material	Halogen-free
Rubber cable	No
Weight	301.1 g
Copper weight of the raw cable	0.072 kg/m

### Environmental requirements

Processing temperature	-5 ... +40 °C
Continuous operating temperature	-35 ... +85 °C
Note on continuous operating temperature	Cable for temperatures ≤ 70 °C (including halogen-free) Insulating parts for temperatures ≤ 105 °C

### Commercial data

PU (SPU)	1 pcs
Packaging type	unpacked
Country of origin	PL
GTIN	4050821018162
Customs tariff number	85444290900

### Product Classification

UNSPSC	26121629
eCl@ss 10.0	27-44-06-04
eCl@ss 9.0	27-44-06-04
ETIM 9.0	EC002587
ETIM 10.0	EC002587
ECCN	NO US CLASSIFICATION

### Environmental Product Compliance

RoHS Compliance Status	Compliant, No Exemption
------------------------	-------------------------

**Approvals / Certificates**

**General approvals**



Approval	Standard	Certificate Name
CCA DEKRA Certification B.V.	EN 61535	NTR NL-7971
KEMA/KEUR DEKRA Certification B.V.	EN 61535	71-123232

**Downloads**

**Environmental Product Compliance**

**Compliance Search**

Environmental Product Compliance 891-8985/116-201	↓
--	---

**Documentation**

**Bid Text**

891-8985/116-201	19.02.2019	xml 3.05 KB	↓
891-8985/116-201	02.12.2014	doc 25.50 KB	↓

**CAD/CAE-Data**

**CAE data**

WSCAD Universe 891-8985/116-201	↓
------------------------------------	---

**1 Compatible Products**

**1.1 Required Accessories**

**1.1.1 Locking system**

**1.1.1.1 Locking system**



**Item No.: 890-111**  
Locking lever; for flying leads; for tool operation; black

**Item No.: 890-131**  
Locking lever; for flying leads; for tool operation; white

**Item No.: 890-101**  
Locking lever; for manual operation; black

**Item No.: 890-121**  
Locking lever; for manual operation; white

## 1.2 Optional Accessories

### 1.2.1 Cover

#### 1.2.1.1 Cover



**Item No.: 897-2003**

Protective cap; Type2; for sockets and plugs; PVC; red

## 1.2.2 Installation

### 1.2.2.1 Mounting accessories



**Item No.: 890-310**

Mounting carrier; 2- to 5-pole; for flying leads; black



**Item No.: 890-311**

Mounting carrier; 2- to 5-pole; for flying leads; white