

## Data Sheet | Item Number: 891-8995/216-801

pre-assembled connecting cable; Eca; Plug/open-ended; 5-pole; Cod. A; H05Z1Z1-F 5G 1.5 mm<sup>2</sup>; 8 m; 1,50 mm<sup>2</sup>; black

<https://www.wago.com/891-8995/216-801>

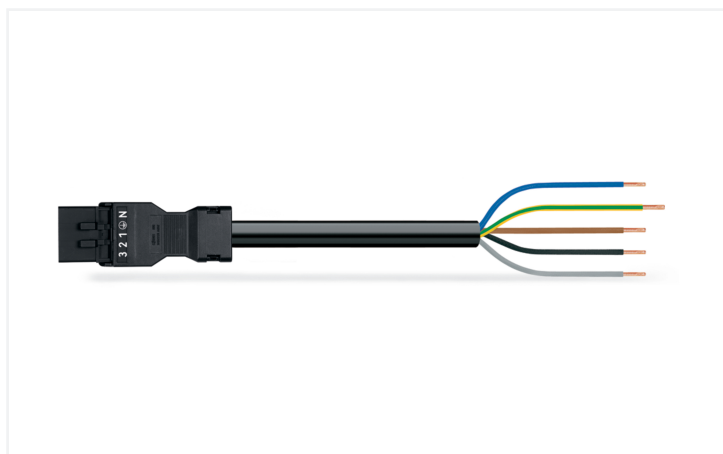

Color: ■ black

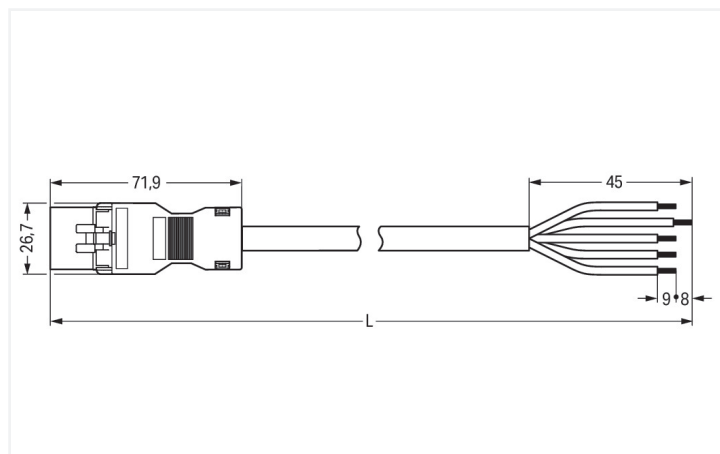

Dimensions in mm

Cable assembly *WINSTA*® MINI with strain relief

For power and signal transmission: The *WINSTA*® MINI cable assembly 5-pole. WAGO pluggable installation connectors are used when requirements repeat or are distributed on a defined pattern, for example for installing grid lighting or flush-mount lighting. The color coding and mechanical coding of the pluggable installation connector ensure error-free installation of the individual components – including protection against mismatching. Standard mains applications for almost any domain of use can be implemented with *WINSTA*® MINI pluggable installation connectors with A coding. Especially if only limited space is available, our smallest pluggable connection system, *WINSTA*® MINI, conveniently displays its strengths. It saves space, and, thanks to Push-in CAGE CLAMP® spring pressure connection technology, it also can be installed quickly, since the installation is low-maintenance and requires no screw connections. Building safety must be ensured at all times, even after the electrical installation stage. The required safety requirements in connection with EU CPR are fully satisfied by this product through fire class E. Not using halogen additives in the manufacture of this cable assembly substantially increases fire safety and reduces environmental contamination.

Fast, secure pluggable connections – cable assemblies from WAGO

The cable is pre-assembled with a plug and a free end. The *WINSTA*® Pluggable Connection System allows pluggable electrical installation. This saves time, lowers costs, and reduces the need for servicing. Enjoy the benefits of the pluggable version of our maintenance-free spring pressure connection technology too! Plan your installation with with strain relief hosting from WAGO.

- pluggable installation connectors with protection against mismatching
- consistent IP40 protection
- for any mains application
- custom-engineered solutions
- quick replacement of defective units during ongoing operation

### Notes

Note

Cables with a different fire class can be found in the eShop.

## Electrical data

Ratings per	IEC/EN 60664-1		
Overvoltage category	III	III	II
Pollution degree	3	2	2
Nominal voltage	400 V	-	-
Rated impulse withstand voltage	6 kV	-	-
Rated current	13 A	-	-

## General information

Note on contact resistance	approx. 1 mΩ of contact resistance approx. 0.25 mΩ contact transition plug/ socket
----------------------------	--

## Connection Data

Total number of potentials	5
Conductor preparation	ultrasonically tip-bonded

## Connection 1

Strip length	9 mm / 0.35 inches
Pole number	5
Wire cross-section	1.5 mm <sup>2</sup>
Strip length (outer insulation)	45 mm
Connection type	Plug - free end

## Physical data

Pin spacing	4.4 mm / 0.173 inches
Width	26.7 mm / 1.051 inches
Height	15.8 mm / 0.622 inches
Total length	8 m

## Mechanical data

Use	General mains applications
Coding	A
Variable coding	No
Marking	N ⊕ 1 2 3
Potential marking	N ⊕ 1 2 3
Mating force of a plug-in connection	approx. 20 ... 70 N (depending on pole number)
Retention force of a plug-in connection	when locked: > 80N
Unmating force of a plug-in connection	when unlocked: approx. 20 ... 70 N (depending on pole number)
Number of mating cycles	200, without resistive load
Connection type	Plug - free end
Type of pre-assembled cable	Connecting cable
Cable type	H05Z1Z1-F 5G1.5
Protection type	IP20; IP40 when mated

## Plug-in connection

Mismating protection	Yes
Note on mismating protection	All WINSTA® components are 100% protected against mismating when: a.) plugging different numbers of poles b.) plugging while rotated 180 c.) plugging while laterally staggered d.) plugging one pole
Locking lever	Can be retrofitted
Locking of plug-in connection	Locking lever
Note on locking system	All connectors for mounted installations (snap-in versions for lighting fixtures or devices, all types of PCB and distribution connectors) are factory-equipped with locking levers to ensure plugs and sockets are securely locked. Additional locking levers are only required for flying leads (plug/socket).

### Material data

Note (material data)	<a href="#">Information on material specifications can be found here</a>
Color	black
Insulation material (main housing)	Polyamide (PA66)
Fire class per EN 50575	E <sub>ca</sub>
Contact material	Copper or copper alloy; surface-treated
Contact Plating	Tin
Fire load	239.947 MJ
Connector color	black
Strain relief color	black
Sheathed cable color	black
Printing color of sheathed cable	white
Halogen-free	Yes
Silicon-free	Yes
Sheath material	Halogen-free
Rubber cable	No
Weight	1245.2 g
Copper weight of the raw cable	0.072 kg/m

### Environmental requirements

Processing temperature	-5 ... +40 °C
Continuous operating temperature	-35 ... +85 °C
Note on continuous operating temperature	Cable for temperatures ≤ 70 °C (including halogen-free) Insulating parts for temperatures ≤ 105 °C

### Commercial data

PU (SPU)	1 pcs
Packaging type	unpacked
Country of origin	PL
GTIN	4055143399807
Customs tariff number	85444290900

### Product Classification

UNSPSC	26121629
eCl@ss 10.0	27-44-06-04
eCl@ss 9.0	27-44-06-04
ETIM 9.0	EC002587
ETIM 10.0	EC002587
ECCN	NO US CLASSIFICATION

### Environmental Product Compliance

RoHS Compliance Status	Compliant, No Exemption
------------------------	-------------------------

## Approvals / Certificates

### General approvals



Approval	Standard	Certificate Name
CCA DEKRA Certification B.V.	EN 61535	NTR NL-7971
KEMA/KEUR DEKRA Certification B.V.	EN 61535	71-123232

### Declarations of conformity and manufacturer's declarations

Approval	Standard	Certificate Name
EU-Declaration of Confor- mity WAGO GmbH & Co. KG	-	-
UK-Declaration of Confor- mity WAGO GmbH & Co. KG	-	-

## Downloads

### Environmental Product Compliance

#### Compliance Search

Environmental Product Compliance 891-8995/216-801	<a href="#">↓</a>
---	-------------------

## Documentation

### Bid Text

891-8995/216-801	19.02.2019	xml 3.01 KB	<a href="#">↓</a>
891-8995/216-801	01.12.2014	doc 25.50 KB	<a href="#">↓</a>

## CAD/CAE-Data

### CAE data

EPLAN Data Portal 891-8995/216-801	<a href="#">↓</a>
WSCAD Universe 891-8995/216-801	<a href="#">↓</a>

## 1 Compatible Products

### 1.1 Required Accessories

#### 1.1.1 Locking system

##### 1.1.1.1 Locking system



[Item No.: 890-111](#)  
Locking lever; for flying leads; for tool operation; black

[Item No.: 890-131](#)  
Locking lever; for flying leads; for tool operation; white

[Item No.: 890-101](#)  
Locking lever; for manual operation; black

[Item No.: 890-121](#)  
Locking lever; for manual operation; white

## 1.2 Optional Accessories

### 1.2.1 Cover

#### 1.2.1.1 Cover



**Item No.: 897-2003**

Protective cap; Type2; for sockets and plugs; PVC; red

## 1.2.2 Installation

### 1.2.2.1 Mounting accessories



**Item No.: 890-310**

Mounting carrier; 2- to 5-pole; for flying leads; black



**Item No.: 890-311**

Mounting carrier; 2- to 5-pole; for flying leads; white