

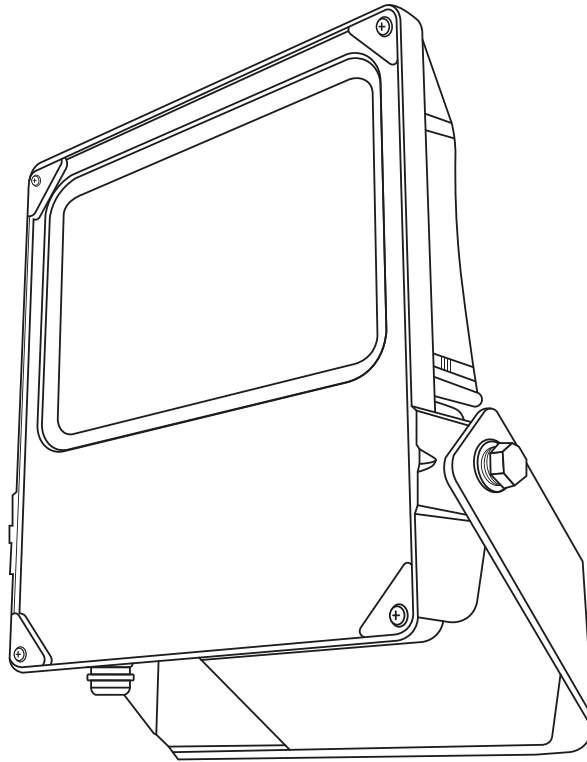

Read these instructions & save for future use

## Floodlight pro | 50W | 120° | warm white 3000K



Article number **146-320**

Brand **Tronix Lighting**

Type **Floodlights**

Contents of this product **1x 50W floodlight 3000K**

Technical datasheet **Digitally available  
on our webshop**



*View instructions and  
technical data also on  
our website*

**TRONIX**



## Before first use

Before getting started with this product, it is advisable to check the order completeness and any damage. If this is the case, please contact Tronix Lighting.

## Description

This professional floodlight features an excellent set of LED chips and is ideally suited for "heavy duty" applications. This means that you not only have beautiful light, but also a product that stands up to extreme weather conditions. Ideal for lighting large buildings, churches, sports fields or business premises.

### Features

- 3x1.0 H05RN-F power cord with schuko plug. Very flexible and strong rubber cable;
- Overvoltage protection protects the fixture against surge voltages;
- Optional other lenses available (see related products);
- 5-year warranty and 50,000 hours of operation.

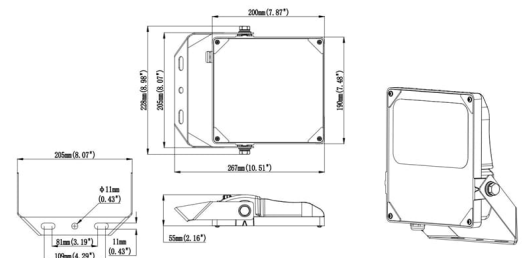

## Installation

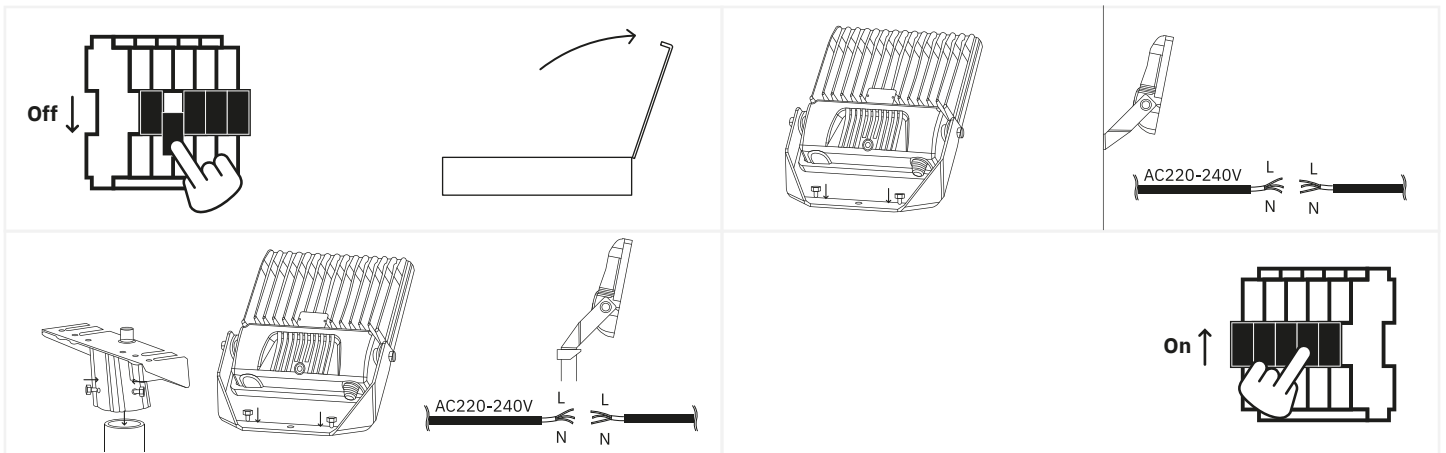

1. Turn off the power and remove the product and accompanying parts from the packaging...;
2. Drill holes at the desired location on the wall and attach the bracket. Then attach the existing wiring through the protrusion at the back of the lamp;
3. Should you be using a lamp post, first place the appropriate adapter (146-360) and place the lamp on it. Then attach the existing wiring through the protrusion on the back of the lamp;
4. Check the complete installation when the floodlight is in place. Should it be in order, the mains power can be reactivated.



## Safety

Safety is a top priority at Tronix Lighting. Therefore, we heartily recommend that you follow the following steps closely:

- Keep this manual carefully for future reference;
- Choose a qualified electrician while installing, maintaining or inspecting this product;
- Never look directly into a light source to avoid possible damage to the eye;
- Always ensure that the relevant power group is on non-active when the product is connected;
- Use only recommended combinations (LED drivers, controllers or dimmers) to avoid injury or damage to the product.

## Technical problems and repair

Should a product not work properly after installation, or if the product exhibits problems over time, it is advisable to check the following elements:

- Check the wiring and installation of your product;
- Check for the presence of interfering elements such as dust, water or other electronics;
- If possible, try disconnecting the product and testing it in another location to rule out a problem at the location;
- Should you be dealing with a WIFI-based product, check and reset your router's settings.

Should the product still not work after testing, it is recommended to send it in for inspection and/or repair. To do so, please contact Tronix Lighting using nearby details and proof of purchase (packing slip).



CARE



SHARE



CONNECT

### Supplier:

Tronix Lighting B.V

Vluchtoord 41  
5406 XP Uden, Netherlands

+31 (0)413 330 380  
sales@tronixlighting.com

## Terms and symbols (as relevant to product)



The **CE mark** indicates that this product complies with EU regulations on safety, health and environmental protection;



The **WEEE symbol** stands for "Waste Electrical and Electronic Equipment Regulation," a directive on the collection, recycling and recovery of electronic waste;



The **Class I symbol** indicates that this product is protected by means of the additional ground cable. This cable is identified by the yellow/green jacket and is attached to this product.

- This product has an **IP66 rating**. This means the housing is touch-safe, fully protected from dust and water-resistant (100 L/min) regardless of angle.