

Data Sheet | Item Number: 891-8992/105-202

pre-assembled connecting cable; Eca; Socket/open-ended; 2-pole; Cod. A; H05VV-F 2 x 1.0 mm²; 2 m; 1,00 mm²; white

<https://www.wago.com/891-8992/105-202>



Color: ■ white

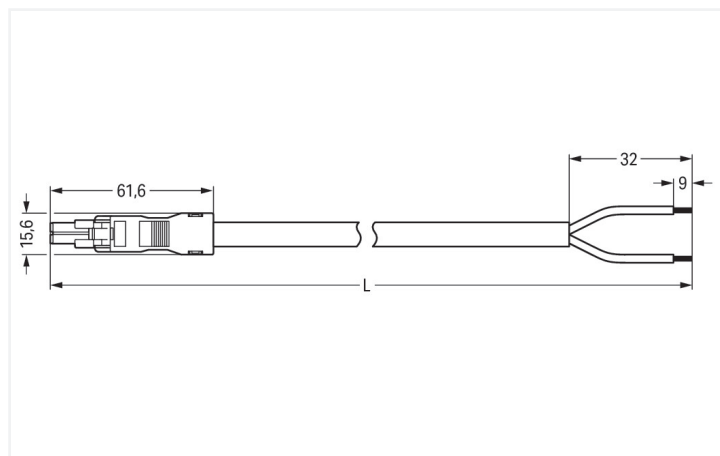

Dimensions in mm

Cable assembly WINSTA® MINI 2-pole

The WINSTA® MINI cable assembly rated current 10 A is the pluggable solution for your application in control cabinets, for lighting connections or on PCBs. Our pluggable installation connectors with spring pressure connection technology work without screw connections. They allow fast, efficient, error-free installation in numerous possible uses. The mechanical coding and color coding of the pluggable installation connector ensure error-free installation of the individual components – including protection against mismatching. The pluggable installation connector offers protection against contact with tools or wires if they are smaller than 1 mm in accordance with protection type IP40. Thanks to the color coding and mechanical A coding of WINSTA® MINI pluggable installation connectors, you can clearly distinguish different circuits. Particularly where space is tight, our smallest pluggable connection system, WINSTA® MINI, conveniently displays its strengths. It is very compact, and, with Push-in CAGE CLAMP® spring pressure connection technology, it also can be installed quickly, since the connection is low-maintenance and can be performed without screw connections. According to the European CPR, the fire class of the cables used for construction is critical for building safety as well. For houses with medium-level safety requirements, cable assemblies with fire class E are suitable.

Pluggable connections instead of screw connections – cable assemblies from WAGO

The cable is pre-assembled with a socket and a free end. The WINSTA® Pluggable Connection System is ideally tailored to the very strict requirements of building installation. It makes electrical installation pluggable, and therefore faster, more reliable, and error-free. Use of this pre-assembled system decreases time spent on assembly and installation errors at the construction site. Now you can also lower installation costs without compromising safety and quality: with fire class E eliminates the need for servicing and prevents unnecessary downtime.

- effective protection against mismatching
- consistent IP40 protection
- with A coding for use in many general mains applications
- flexible installation to save space
- quick replacement of defective units during ongoing operation

Notes

Note Cables with a different fire class can be found in the eShop.

Electrical data

| Ratings per | IEC/EN 60664-1 | | | General information | |
|---------------------------------|----------------|-----|----|----------------------------|--|
| Overvoltage category | III | III | II | Note on contact resistance | approx. 1 mΩ of contact resistance approx. 0.25 mΩ contact transition plug/ socket |
| Pollution degree | 3 | 2 | 2 | | |
| Nominal voltage | 250 V | - | - | | |
| Rated impulse withstand voltage | 4 kV | - | - | | |
| Rated current | 10 A | - | - | | |

Connection Data

| | | | |
|----------------------------|---------------------------|---------------------------------|--------------------|
| Total number of potentials | 2 | Connection 1 | |
| Conductor preparation | ultrasonically tip-bonded | Strip length | 9 mm / 0.35 inches |
| | | Pole number | 2 |
| | | Wire cross-section | 1 mm ² |
| | | Strip length (outer insulation) | 32 mm |
| | | Connection type | Socket - free end |

Physical data

| | |
|--------------|------------------------|
| Pin spacing | 4.4 mm / 0.173 inches |
| Width | 15.6 mm / 0.614 inches |
| Height | 13.2 mm / 0.52 inches |
| Total length | 2 m |

Mechanical data

| | |
|---|---|
| Use | General mains applications |
| Coding | A |
| Variable coding | No |
| Marking | L N |
| Potential marking | L N |
| Mating force of a plug-in connection | approx. 20 ... 70 N (depending on pole number) |
| Retention force of a plug-in connection | when locked: > 80N |
| Unmating force of a plug-in connection | when unlocked: approx. 20 ... 70 N (depending on pole number) |
| Number of mating cycles | 200, without resistive load |
| Connection type | Socket - free end |
| Type of pre-assembled cable | Connecting cable |
| Cable type | H05VV-F 2x1 |
| Protection type | IP40 |

Plug-in connection

| | |
|-------------------------------|--|
| Mismating protection | Yes |
| Note on mismating protection | All WINSTA® components are 100% protected against mismating when: a.) plugging different numbers of poles b.) plugging while rotated 180 c.) plugging while laterally staggered d.) plugging one pole |
| Locking lever | Can be retrofitted |
| Locking of plug-in connection | Locking lever |
| Note on locking system | All connectors for mounted installations (snap-in versions for lighting fixtures or devices, all types of PCB and distribution connectors) are factory-equipped with locking levers to ensure plugs and sockets are securely locked. Additional locking levers are only required for flying leads (plug/socket). |

Material data

| | |
|------------------------------------|--|
| Note (material data) | Information on material specifications can be found here |
| Color | white |
| Insulation material (main housing) | Polyamide (PA66) |
| Fire class per EN 50575 | E _{ca} |
| Contact material | Copper or copper alloy; surface-treated |
| Contact Plating | Tin |
| Fire load | 59.698 MJ |
| Connector color | white |
| Strain relief color | white |
| Sheathed cable color | white |
| Printing color of sheathed cable | black |
| Halogen-free | No |
| Silicon-free | Yes |
| Sheath material | PVC |
| Rubber cable | No |
| Weight | 118.9 g |
| Copper weight of the raw cable | 0.0192 kg/m |

Environmental requirements

| | |
|--|---|
| Processing temperature | -5 ... +40 °C |
| Continuous operating temperature | -35 ... +85 °C |
| Note on continuous operating temperature | Cable for temperatures ≤ 70 °C (including halogen-free) Insulating parts for temperatures ≤ 105 °C |

Commercial data

| | |
|-----------------------|---------------|
| PU (SPU) | 1 pcs |
| Packaging type | unpacked |
| Country of origin | PL |
| GTIN | 4055143362290 |
| Customs tariff number | 85444290900 |

Product Classification

| | |
|-------------|----------------------|
| UNSPSC | 26121629 |
| eCl@ss 10.0 | 27-44-06-04 |
| eCl@ss 9.0 | 27-44-06-04 |
| ETIM 9.0 | EC002587 |
| ETIM 10.0 | EC002587 |
| ECCN | NO US CLASSIFICATION |

Environmental Product Compliance

| | |
|------------------------|-------------------------|
| RoHS Compliance Status | Compliant, No Exemption |
|------------------------|-------------------------|

Downloads

Environmental Product Compliance

Compliance Search

| | |
|--|-------------------|
| Environmental Product Compliance 891-8992/105-202 | ↓ |
|--|-------------------|

Documentation

Bid Text

| | | | |
|------------------|------------|-----------------|-------------------|
| 891-8992/105-202 | 19.02.2019 | xml 2.99 KB | ↓ |
| 891-8992/105-202 | 21.11.2014 | doc 24.00 KB | ↓ |

CAD/CAE-Data

CAE data

| | |
|---------------------------------------|-------------------|
| EPLAN Data Portal 891-8992/105-202 | ↓ |
| WSCAD Universe 891-8992/105-202 | ↓ |

1 Compatible Products

1.1 Required Accessories

1.1.1 Locking system

1.1.1.1 Locking system



[Item No.: 890-111](#)
Locking lever; for flying leads; for tool operation; black

[Item No.: 890-131](#)
Locking lever; for flying leads; for tool operation; white

[Item No.: 890-101](#)
Locking lever; for manual operation; black

[Item No.: 890-121](#)
Locking lever; for manual operation; white

1.2 Optional Accessories

1.2.1 Cover

1.2.1.1 Cover



Item No.: 897-2001

Protective cap; Type1; for sockets and plugs; PVC; red

1.2.2 Installation

1.2.2.1 Mounting accessories



Item No.: 890-310

Mounting carrier; 2- to 5-pole; for flying leads; black



Item No.: 890-311

Mounting carrier; 2- to 5-pole; for flying leads; white