

Pioneering for You

wilo

Wilo-EFC 0.25–90 kW



en Installation and operating instructions

Contents

1 Introduction	4
1.1 Purpose of the Operating Guide	4
1.2 Additional Resources	4
1.3 Manual and Software Version	4
1.4 Product Overview	4
1.5 Approvals and Certifications	8
1.6 Disposal	8
2 Safety	9
2.1 Safety Symbols	9
2.2 Qualified Personnel	9
2.3 Safety Precautions	9
3 Mechanical Installation	11
3.1 Unpacking	11
3.2 Installation Environments	11
3.3 Mounting	12
4 Electrical Installation	14
4.1 Safety Instructions	14
4.2 EMC-compliant Installation	14
4.3 Grounding	14
4.4 Wiring Schematic	16
4.5 Access	18
4.6 Motor Connection	18
4.7 AC Mains Connection	19
4.8 Control Wiring	19
4.8.1 Control Terminal Types	19
4.8.2 Wiring to Control Terminals	21
4.8.3 Enabling Motor Operation (Terminal 27)	21
4.8.4 Voltage/Current Input Selection (Switches)	22
4.8.5 Safe Torque Off (STO)	22
4.8.6 RS485 Serial Communication	22
4.9 Installation Check List	24
5 Commissioning	25
5.1 Safety Instructions	25
5.2 Applying Power	25
5.3 Local Control Panel Operation	25
5.3.1 Graphic Local Control Panel Layout	25

5.3.2 Parameter Settings	27
5.3.3 Uploading/Downloading Data to/from the LCP	27
5.3.4 Changing Parameter Settings	27
5.3.5 Restoring Default Settings	27
5.4 Basic Programming	28
5.4.1 Commissioning with SmartStart	28
5.4.2 Commissioning via [Main Menu]	28
5.4.3 Asynchronous Motor Set-up	29
5.4.4 PM Motor Setup in VVC ⁺	29
5.4.5 SynRM Motor Set-up with VVC ⁺	30
5.4.6 Automatic Energy Optimization (AEO)	31
5.4.7 Automatic Motor Adaptation (AMA)	31
5.5 Checking Motor Rotation	32
5.6 Local-control Test	32
5.7 System Start-up	32
6 Application Set-up Examples	33
7 Maintenance, Diagnostics, and Troubleshooting	37
7.1 Maintenance and Service	37
7.2 Status Messages	37
7.3 Warning and Alarm Types	39
7.4 List of Warnings and Alarms	40
7.5 Troubleshooting	47
8 Specifications	50
8.1 Electrical Data	50
8.1.1 Mains Supply 1x200–240 V AC	50
8.1.2 Mains Supply 3x200–240 V AC	51
8.1.3 Mains Supply 1x380–480 V AC	54
8.1.4 Mains Supply 3x380–480 V AC	55
8.1.5 Mains Supply 3x525–600 V AC	59
8.1.6 Mains Supply 3x525–690 V AC	63
8.2 Mains Supply	66
8.3 Motor Output and Motor Data	66
8.4 Ambient Conditions	67
8.5 Cable Specifications	67
8.6 Control Input/Output and Control Data	67
8.7 Connection Tightening Torques	70
8.8 Fuses and Circuit Breakers	71
8.9 Power Ratings, Weight, and Dimensions	78

9 Appendix	80
9.1 Symbols, Abbreviations, and Conventions	80
9.2 Parameter Menu Structure	80
Index	86

1 Introduction

1.1 Purpose of the Operating Guide

This operating guide provides information for safe installation and commissioning of the frequency converter.

The operating guide is intended for use by qualified personnel. Read and follow the instructions to use the frequency converter safely and professionally, and pay particular attention to the safety instructions and general warnings. Always keep this operating guide available with the frequency converter.

1.2 Additional Resources

Other resources are available to understand advanced frequency converter functions and programming.

- The *Programming Guide* provides greater detail on working with parameters and many application examples.
- The *Design Guide* provides detailed information about capabilities and functionality to design motor control systems.
- Instructions for operation with optional equipment.

1.3 Manual and Software Version

This manual is regularly reviewed and updated. All suggestions for improvement are welcome.

Table 1.1 shows the manual version and the corresponding software version.

Edition	Remarks	Software version
MG21L1xx	Initial revision	2.6x

Table 1.1 Manual and Software Version

1.4 Product Overview

1.4.1 Intended Use

The frequency converter is an electronic motor controller intended for:

- Regulation of motor speed in response to system feedback or to remote commands from external controllers. A power drive system consists of the frequency converter, the motor, and equipment driven by the motor.
- System and motor status surveillance.

Depending on configuration, the frequency converter can be used in standalone applications or form part of a larger appliance or installation.

The frequency converter is allowed for use in residential, industrial, and commercial environments in accordance with local laws, standards, and emission limits as described in the design guide.

Single-phase frequency converters (S2 and S4) installed in the EU

The following limitations apply:

- Units with an input current below 16 A and an input power above 1 kW (1.5 hp) are only intended for professional use in trades, professions, or industries and not for sale to the general public.
- Designated application areas are public pools, public water supplies, agriculture, commercial buildings, and industries. All other single-phase units are only intended for use in private low-voltage systems interfacing with public supply only at a medium or high-voltage level.
- Operators of private systems must ensure that the EMC environment complies with IEC 61000-3-6 and/or the contractual agreements.

NOTICE

In a residential environment, this product can cause radio interference, in which case supplementary mitigation measures may be required.

Foreseeable misuse

Do not use the frequency converter in applications, which are non-compliant with specified operating conditions and environments. Ensure compliance with the conditions specified in *chapter 8 Specifications*.

1.4.2 Features

The WILO EFC is designed for water and wastewater applications. The range of standard and optional features includes:

- Cascade control.
- Dry run detection.
- End-of-curve detection.
- SmartStart.
- Motor alternation.
- Deragging.
- 2-step ramps.
- Flow confirmation.
- Check valve protection.
- Safe Torque Off.
- Low flow detection.
- Pre/post lubrication.
- Pipe fill mode.
- Sleep mode.
- Real-time clock.
- User-configurable info texts.
- Warnings and alarms.
- Password protection.
- Overload protection.
- Smart logic control.
- Dual power rating (high/normal overload).

1.4.3 Exploded Views

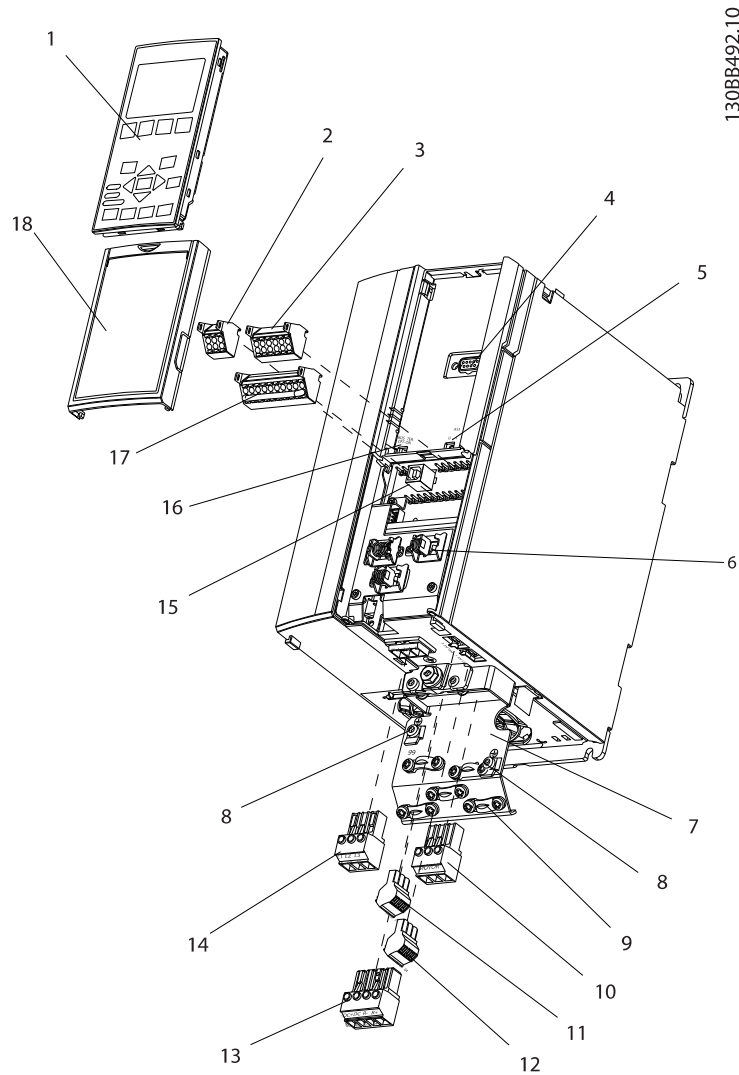

1	Local control panel (LCP)	10	Motor output terminals 96 (U), 97 (V), 98 (W)
2	RS485 fieldbus connector (+68, -69)	11	Relay 2 (01, 02, 03)
3	Analog I/O connector	12	Relay 1 (04, 05, 06)
4	LCP input plug	13	Brake (-81, +82) and load sharing (-88, +89) terminals
5	Analog switches (A53), (A54)	14	Mains input terminals 91 (L1), 92 (L2), 93 (L3)
6	Cable shield connector	15	USB connector
7	Ground termination plate	16	Fieldbus terminal switch
8	Grounding clamp (PE)	17	Digital I/O and 24 V supply
9	Shielded cable grounding clamps and strain relief	18	Cover

Illustration 1.1 Exploded View, Example Enclosure Sizes A2, and A3, IP20

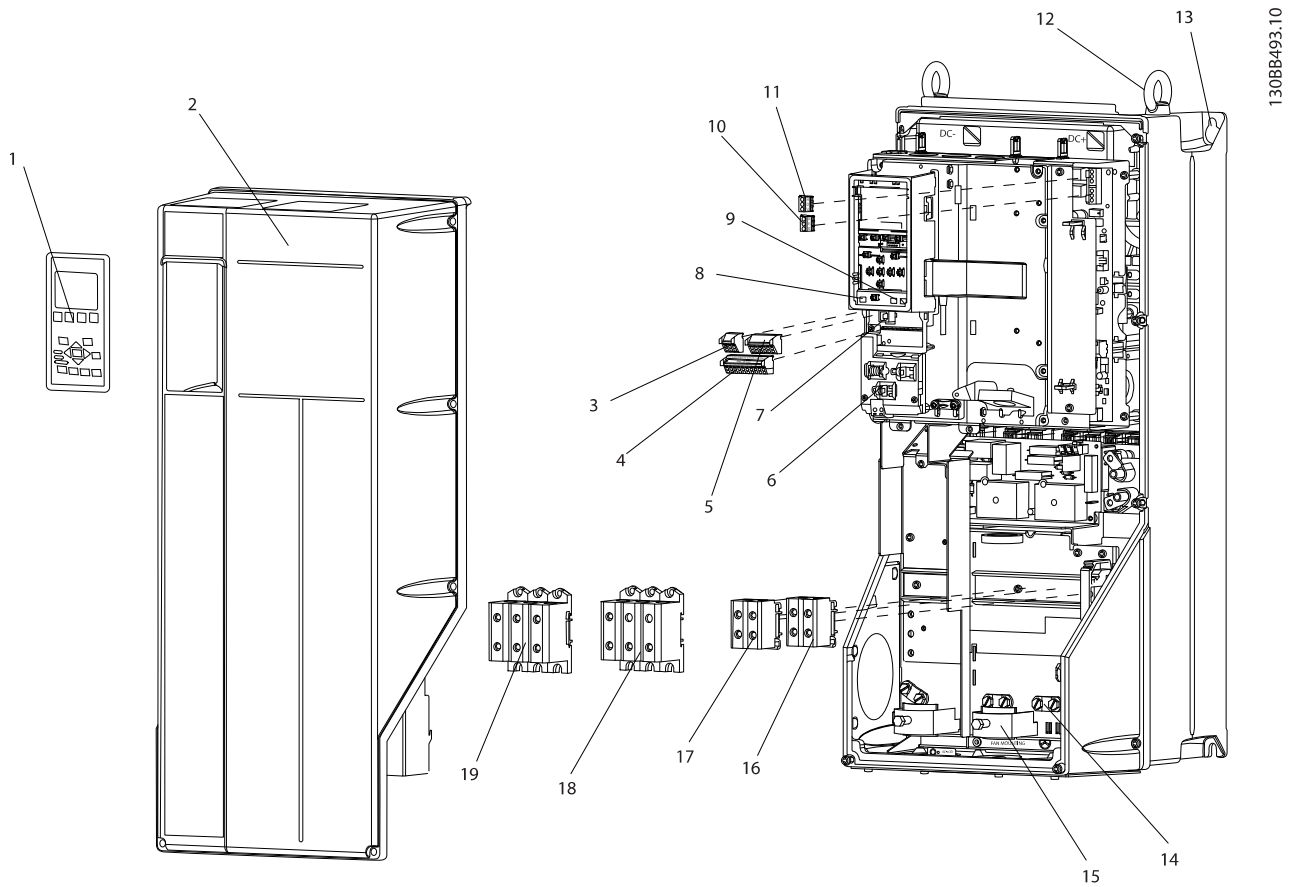

1308B493.10

1	Local control panel (LCP)	11	Relay 2 (04, 05, 06)
2	Cover	12	Lifting ring
3	RS485 fieldbus connector	13	Mounting slot
4	Digital I/O and 24 V supply	14	Grounding clamp (PE)
5	Analog I/O connector	15	Cable shield connector
6	Cable shield connector	16	Brake terminal (-81, +82)
7	USB connector	17	Load sharing terminal (DC bus) (-88, +89)
8	Fieldbus terminal switch	18	Motor output terminals 96 (U), 97 (V), 98 (W)
9	Analog switches (A53), (A54)	19	Mains input terminals 91 (L1), 92 (L2), 93 (L3)
10	Relay 1 (01, 02, 03)	-	-

Illustration 1.2 Exploded View Example Enclosure Sizes C1 and C2, IP55, and IP66

Illustration 1.3 is a block diagram of the internal components of the frequency converter.

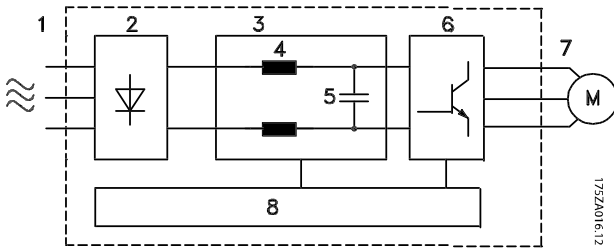

Area	Title	Functions
1	Mains input	<ul style="list-style-type: none"> 3-phase AC mains supply to the frequency converter.
2	Rectifier	<ul style="list-style-type: none"> The rectifier bridge converts the AC input to DC current to supply inverter power.
3	DC bus	<ul style="list-style-type: none"> The intermediate DC bus circuit handles the DC current.
4	DC reactors	<ul style="list-style-type: none"> Filter the intermediate DC circuit voltage. Provide mains transient protection. Reduce RMS current. Raise the power factor reflected back to the line. Reduce harmonics on the AC input.
5	Capacitor bank	<ul style="list-style-type: none"> Stores the DC power. Provides ride-through protection for short power losses.
6	Inverter	<ul style="list-style-type: none"> Converts the DC into a controlled PWM AC waveform for a controlled variable output to the motor.
7	Output to motor	<ul style="list-style-type: none"> Regulated 3-phase output power to the motor.
8	Control circuitry	<ul style="list-style-type: none"> Input power, internal processing, output, and motor current are monitored to provide efficient operation and control. User interface and external commands are monitored and performed. Status output and control can be provided.

Illustration 1.3 Frequency Converter Block Diagram

1.4 Enclosure Sizes and Power Ratings

For enclosure sizes and power ratings of the frequency converters, refer to *chapter 8.9 Power Ratings, Weight, and Dimensions*.

1.5 Approvals and Certifications

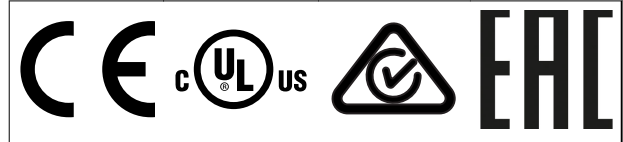

Table 1.2 Approvals and Certifications

More approvals and certifications are available. Contact the local Wilo office or partner.

NOTICE

Frequency converters of enclosure size T7 (525–690 V) are not UL listed.

The frequency converter complies with UL 508C thermal memory retention requirements. For more information, refer to the section *Motor Thermal Protection* in the product-specific *design guide*.

For compliance with the European Agreement concerning International Carriage of Dangerous Goods by Inland Waterways (ADN), refer to *ADN-compliant Installation* in the product-specific *design guide*.

1.6 Disposal



Do not dispose of equipment containing electrical components together with domestic waste.
Collect it separately in accordance with local and currently valid legislation.

2 Safety

2.1 Safety Symbols

The following symbols are used in this guide:

⚠ WARNING

Indicates a potentially hazardous situation that could result in death or serious injury.

⚠ CAUTION

Indicates a potentially hazardous situation that could result in minor or moderate injury. It can also be used to alert against unsafe practices.

NOTICE

Indicates important information, including situations that can result in damage to equipment or property.

2.2 Qualified Personnel

Correct and reliable transport, storage, installation, operation, and maintenance are required for the trouble-free and safe operation of the frequency converter. Only qualified personnel are allowed to install and operate this equipment.

Qualified personnel are defined as trained staff, who are authorized to install, commission, and maintain equipment, systems, and circuits in accordance with pertinent laws and regulations. Also, the qualified personnel must be familiar with the instructions and safety measures described in this manual.

2.3 Safety Precautions

⚠ WARNING

HIGH VOLTAGE

Frequency converters contain high voltage when connected to AC mains input, DC supply, or load sharing. Failure to perform installation, start-up, and maintenance by qualified personnel can result in death or serious injury.

- Only qualified personnel must perform installation, start-up, and maintenance.
- Before performing any service or repair work, use an appropriate voltage measuring device to make sure that there is no remaining voltage on the drive.

⚠ WARNING

UNINTENDED START

When the frequency converter is connected to AC mains, DC supply, or load sharing, the motor may start at any time. Unintended start during programming, service, or repair work can result in death, serious injury, or property damage. The motor can start via an external switch, a fieldbus command, an input reference signal from the LCP, or after a cleared fault condition.

To prevent unintended motor start:

- Disconnect the frequency converter from the mains.
- Press [Off/Reset] on the LCP before programming parameters.
- Completely wire and assemble the frequency converter, motor, and any driven equipment before connecting the frequency converter to AC mains, DC supply, or load sharing.

⚠ WARNING

DISCHARGE TIME

The frequency converter contains DC-link capacitors, which can remain charged even when the frequency converter is not powered. High voltage can be present even when the warning LED indicator lights are off. Failure to wait the specified time after power has been removed before performing service or repair work can result in death or serious injury.

- Stop the motor.
- Disconnect AC mains and remote DC-link power supplies, including battery back-ups, UPS, and DC-link connections to other frequency converters.
- Disconnect or lock PM motor.
- Wait for the capacitors to discharge fully. The minimum duration of waiting time is specified in *Table 2.1*.
- Before performing any service or repair work, use an appropriate voltage measuring device to make sure that the capacitors are fully discharged.

Voltage [V]	Minimum waiting time (minutes)		
	4	7	15
200–240	0.25–3.7 kW (0.34–5 hp)	–	5.5–45 kW (7.5–60 hp)
380–480	0.37–7.5 kW (0.5–10 hp)	–	11–90 kW (15–121 hp)
525–600	0.75–7.5 kW (1–10 hp)	–	11–90 kW (15–121 hp)
525–690	–	1.1–7.5 kW (1.5–10 hp)	11–90 kW (15–121 hp)

Table 2.1 Discharge Time

⚠ WARNING

LEAKAGE CURRENT HAZARD

Leakage currents exceed 3.5 mA. Failure to ground the frequency converter properly can result in death or serious injury.

- Ensure the correct grounding of the equipment by a certified electrical installer.

⚠ WARNING

EQUIPMENT HAZARD

Contact with rotating shafts and electrical equipment can result in death or serious injury.

- Ensure that only trained and qualified personnel perform installation, start-up, and maintenance.
- Ensure that electrical work conforms to national and local electrical codes.
- Follow the procedures in this guide.

⚠ WARNING

**UNINTENDED MOTOR ROTATION
WINDMILLING**

Unintended rotation of permanent magnet motors creates voltage and can charge the unit, resulting in death, serious injury, or equipment damage.

- Ensure that permanent magnet motors are blocked to prevent unintended rotation.

⚠ CAUTION

INTERNAL FAILURE HAZARD

An internal failure in the frequency converter can result in serious injury when the frequency converter is not properly closed.

- Ensure that all safety covers are in place and securely fastened before applying power.

3 Mechanical Installation

3.1 Unpacking

3.1.1 Items Supplied

Items supplied may vary according to product configuration.

- Make sure the items supplied and the information on the nameplate correspond to the order confirmation.
- Check the packaging and the frequency converter visually for damage caused by inappropriate handling during shipment. File any claim for damage with the carrier. Retain damaged parts for clarification.

3.1.2 Storage

Ensure that the requirements for storage are fulfilled. Refer to *chapter 8.4 Ambient Conditions* for further details.

3.2 Installation Environments

NOTICE

In environments with airborne liquids, particles, or corrosive gases, ensure that the IP/type rating of the equipment matches the installation environment. Failure to meet requirements for ambient conditions can reduce the lifetime of the frequency converter. Ensure that requirements for air humidity, temperature, and altitude are met.

Vibration and shock

The frequency converter complies with requirements for units mounted on the walls and floors of production premises, and in panels bolted to walls or floors.

For detailed ambient conditions specifications, refer to *chapter 8.4 Ambient Conditions*.

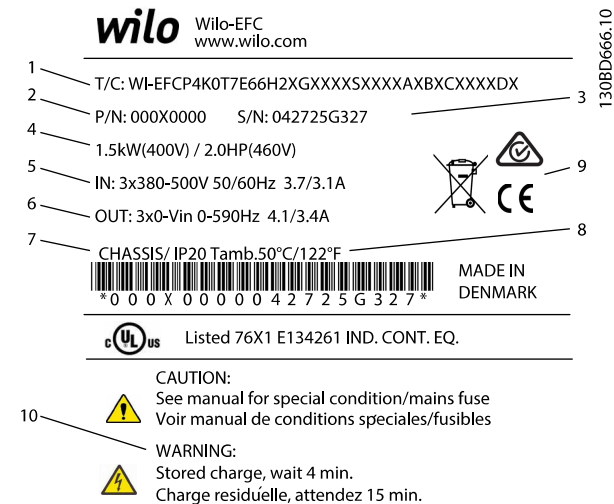

1	Type code
2	Ordering number
3	Serial number
4	Power rating
5	Input voltage, frequency, and current (at low/high voltages)
6	Output voltage, frequency, and current (at low/high voltages)
7	Enclosure type and IP rating
8	Maximum ambient temperature
9	Certifications
10	Discharge time (Warning)

Illustration 3.1 Product Nameplate (Example)

NOTICE

Do not remove the nameplate from the frequency converter. Removing the nameplate voids the warranty.

3.3 Mounting

NOTICE

Improper mounting can result in overheating and reduced performance.

Cooling

- Ensure that top and bottom clearance for air cooling is provided. See *Illustration 3.2* for clearance requirements.

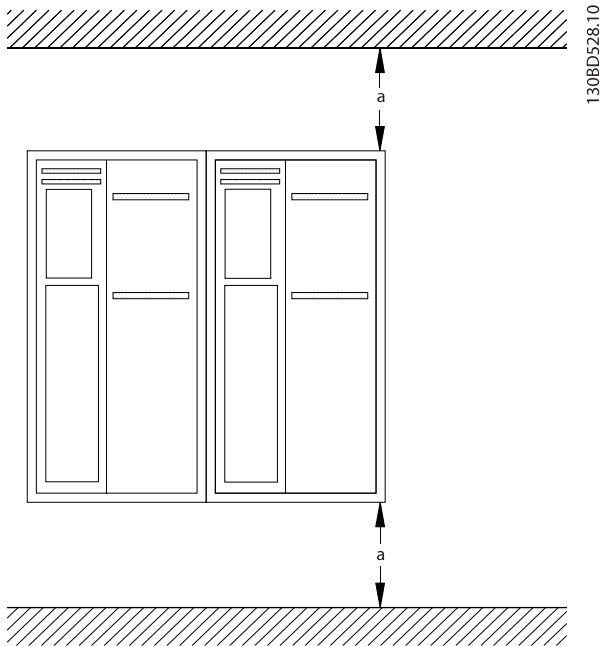

Enclosure	A2–A5	B1–B4	C1, C3	C2, C4
a [mm (in)]	100 (3.9)	200 (7.9)	200 (7.9)	225 (8.9)

Illustration 3.2 Top and Bottom Cooling Clearance

Lifting

- To determine a safe lifting method, check the weight of the unit, see *chapter 8.9 Power Ratings, Weight, and Dimensions*.
- Ensure that the lifting device is suitable for the task.
- If necessary, plan for a hoist, crane, or forklift with the appropriate rating to move the unit.
- For lifting, use the hoist rings on the unit, when provided.

Mounting

1. Ensure that the strength of the mounting location supports the unit weight. The frequency converter allows side-by-side installation.
2. Locate the unit as near to the motor as possible. Keep the motor cables as short as possible.
3. Mount the unit vertically to a solid flat surface or to the optional backplate to provide cooling airflow.
4. Use the slotted mounting holes on the unit for wall mounting, when provided.

Mounting with backplate and railings

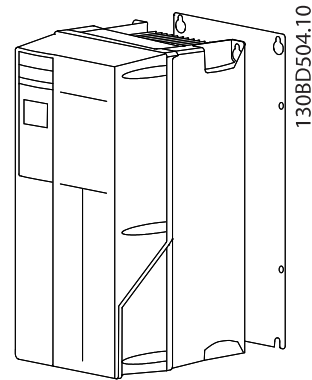

Illustration 3.3 Proper Mounting with Backplate

NOTICE

A backplate is required when mounted on railings.

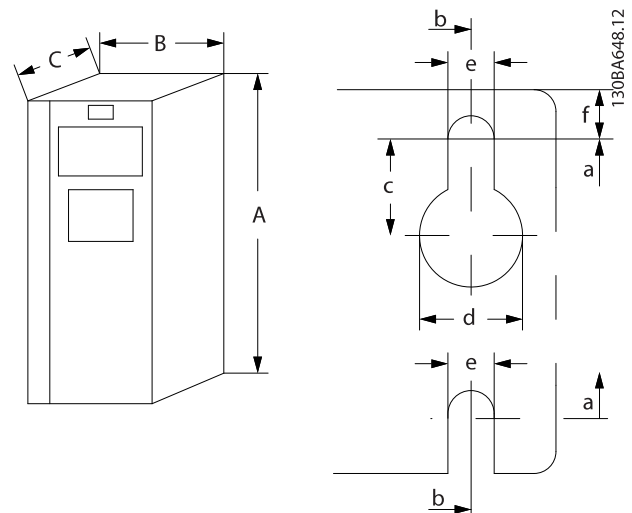

Illustration 3.4 Top and Bottom Mounting Holes (See *chapter 8.9 Power Ratings, Weight, and Dimensions*)

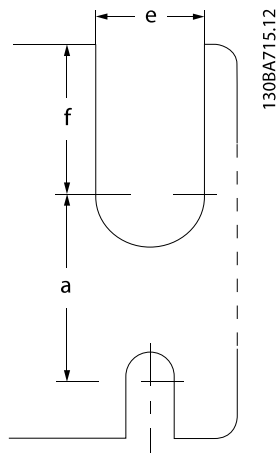

Illustration 3.5 Top and Bottom Mounting Holes (B4, C3, and C4)

4 Electrical Installation

4.1 Safety Instructions

See *chapter 2 Safety* for general safety instructions.

⚠ WARNING

INDUCED VOLTAGE

Induced voltage from output motor cables that run together can charge equipment capacitors, even with the equipment turned off and locked out. Failure to run output motor cables separately or to use shielded cables could result in death or serious injury.

- Run output motor cables separately, or
- Use shielded cables.

⚠ CAUTION

SHOCK HAZARD

The frequency converter can cause a DC current in the PE conductor. Failure to follow the recommendation may lead to the RCD not providing the intended protection.

- When a residual current-operated protective device (RCD) is used for protection against electrical shock, only an RCD of Type B is allowed on the supply side.

Overcurrent protection

- Extra protective equipment, such as short-circuit protection or motor thermal protection between frequency converter and motor, is required for applications with multiple motors.
- Input fusing is required to provide short circuit and overcurrent protection. If not factory-supplied, the installer must provide fuses. See maximum fuse ratings in *chapter 8.8 Fuses and Circuit Breakers*.

Wire type and ratings

- All wiring must comply with local and national regulations regarding cross-section and ambient temperature requirements.
- Power connection wire recommendation: Minimum 75 °C (167 °F) rated copper wire.

See *chapter 8.1 Electrical Data* and *chapter 8.5 Cable Specifications* for recommended wire sizes and types.

4.2 EMC-compliant Installation

To obtain an EMC-compliant installation, follow the instructions provided in *chapter 4.3 Grounding*, *chapter 4.4 Wiring Schematic*, *chapter 4.6 Motor Connection*, and *chapter 4.8 Control Wiring*.

4.3 Grounding

⚠ WARNING

LEAKAGE CURRENT HAZARD

Leakage currents exceed 3.5 mA. Failure to ground the frequency converter properly could result in death or serious injury.

- Ensure the correct grounding of the equipment by a certified electrical installer.

For electrical safety

- Ground the frequency converter in accordance with applicable standards and directives.
- Use a dedicated ground wire for input power, motor power, and control wiring.
- Do not ground 1 frequency converter to another in a daisy-chain fashion (see *Illustration 4.1*).
- Keep the ground wire connections as short as possible.
- Follow motor manufacturer wiring requirements.
- Minimum cable cross-section for the ground wires:
 - Same diameter as the mains cable for mains cable cross-section up to 16 mm² (6 AWG)
 - 16 mm² (6 AWG) for mains cable cross-section between 16 mm² (6 AWG) and 35 mm² (1 AWG)
 - Half the diameter of the mains cable for mains cable cross-section bigger than 35 mm² (1 AWG).

Separately terminate individual ground wires, both complying with the dimension requirements.

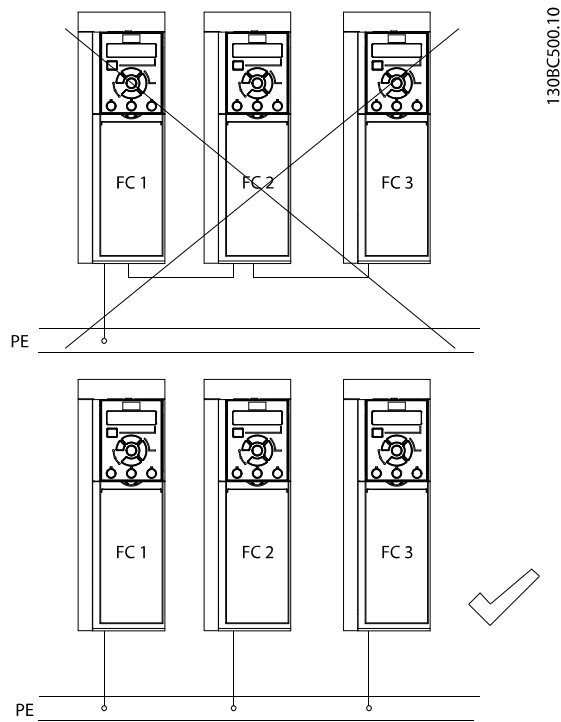

Illustration 4.1 Grounding Principle

For EMC-compliant installation

- Establish electrical contact between the cable shield and the frequency converter enclosure by using metal cable glands or by using the clamps provided on the equipment (see *chapter 4.6 Motor Connection*).
- Use high-strand wire to reduce burst transient.
- Do not use pigtails.

NOTICE

POTENTIAL EQUALIZATION

Risk of burst transient when the ground potential between the frequency converter and the control system is different. Install equalizing cables between the system components. Recommended cable cross-section: 16 mm² (6 AWG).

4.4 Wiring Schematic

4

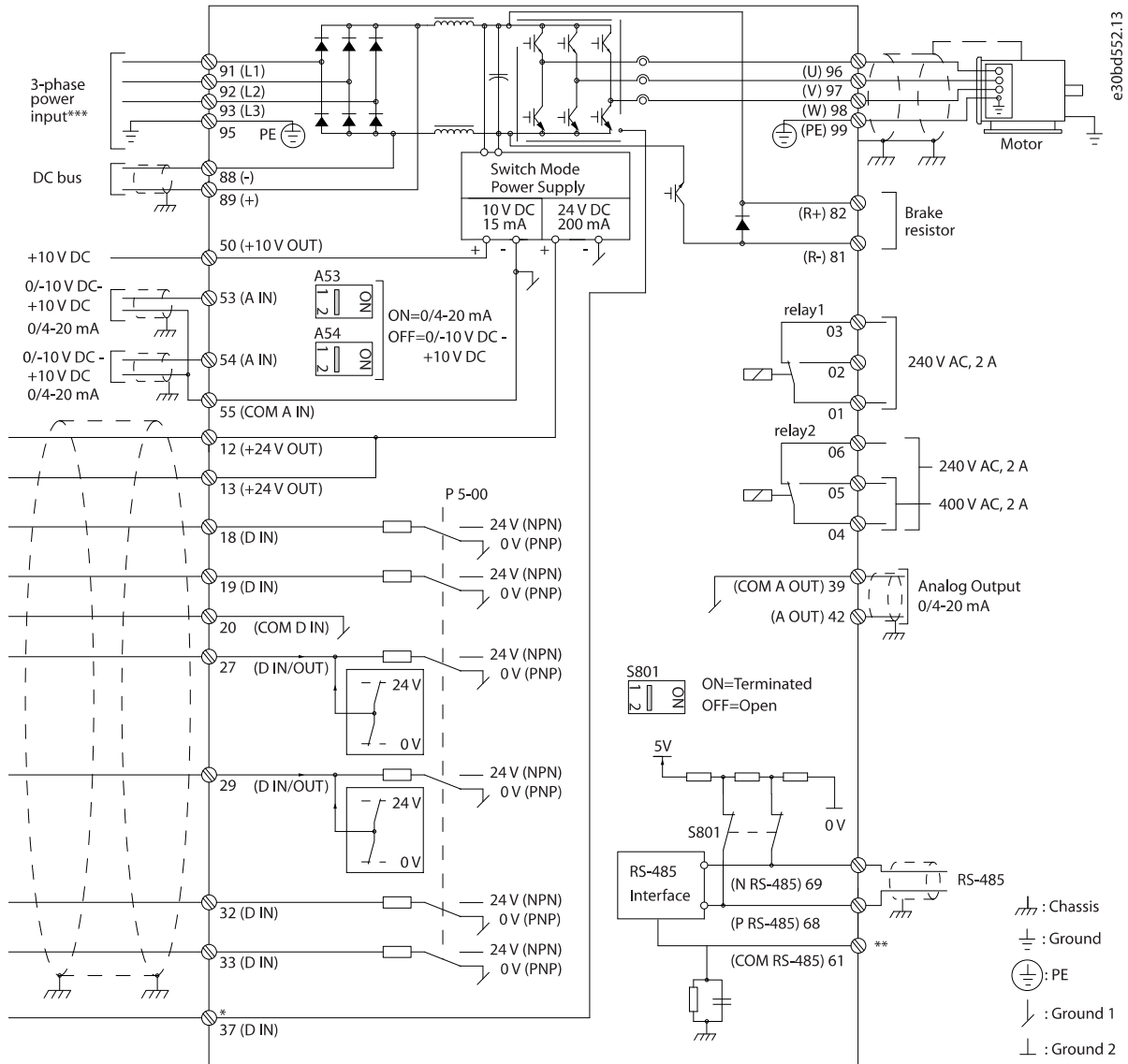

Illustration 4.2 Basic Wiring Schematic

A=Analog, D=Digital

*Terminal 37 (optional) is used for Safe Torque Off. For Safe Torque Off installation instructions, refer to the *Safe Torque Off Operating Instructions for Wilo VLT® Frequency Converters*.

**Do not connect cable screen.

***For 1-phase power input, wire to L1 and L2.

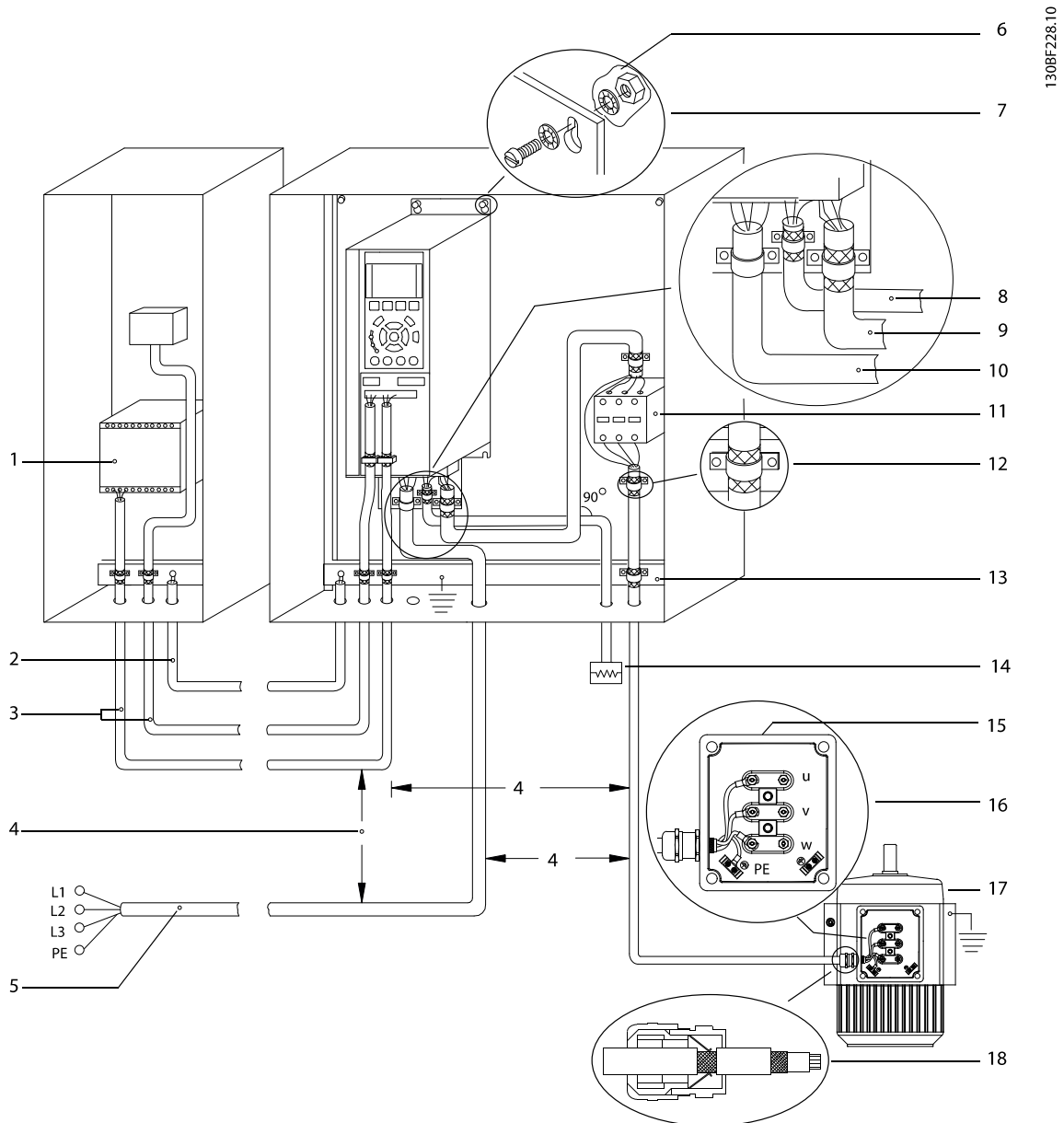

130BF228.10

1	PLC.	10	Mains cable (unshielded).
2	Minimum 16 mm ² (6 AWG) equalizing cable.	11	Output contactor, and so on.
3	Control cables.	12	Cable insulation stripped.
4	Minimum 200 mm (7.9 in) between control cables, motor cables, and mains cables.	13	Common ground busbar. Follow local and national requirements for cabinet grounding.
5	Mains supply.	14	Brake resistor.
6	Bare (unpainted) surface.	15	Metal box.
7	Star washers.	16	Connection to motor.
8	Brake cable (shielded).	17	Motor.
9	Motor cable (shielded).	18	EMC cable gland.

Illustration 4.3 Example of Proper EMC Installation

For more information about EMC, see *chapter 4.2 EMC-compliant Installation*.

NOTICE

EMC INTERFERENCE

Use shielded cables for motor and control wiring, and separate cables for input power, motor wiring, and control wiring. Failure to isolate power, motor, and control cables can result in unintended behavior or reduced performance. Minimum 200 mm (7.9 in) clearance is required between power, motor, and control cables.

Tighten the cover screws using the tightening torques specified in *Table 4.1*.

Enclosure	IP55	IP66
A4/A5	2 (18)	2 (18)
B1/B2	2.2 (19)	2.2 (19)
C1/C2	2.2 (19)	2.2 (19)
No screws to tighten for A2/A3/B3/B4/C3/C4.		

Table 4.1 Tightening Torques for Covers [N•m (in•lb)]

4.5 Access

1. Remove the cover with a screwdriver (See *Illustration 4.4*) or by loosening the attaching screws (See *Illustration 4.5*).

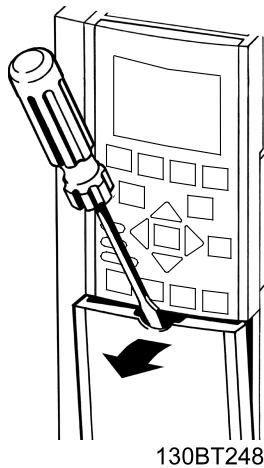

Illustration 4.4 Access to Wiring for IP20 and IP21 Enclosures

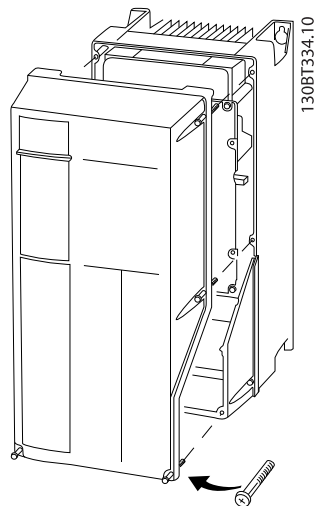

Illustration 4.5 Access to Wiring for IP55 and IP66 Enclosures

4.6 Motor Connection

WARNING

INDUCED VOLTAGE

Induced voltage from output motor cables that run together can charge equipment capacitors, even with the equipment turned off and locked out. Failure to run output motor cables separately or use shielded cables could result in death or serious injury.

- Run output motor cables separately, or
- Use shielded cables.
- Comply with local and national electrical codes for cable sizes. For maximum wire sizes, see *chapter 8.1 Electrical Data*.
- Follow motor manufacturer wiring requirements.
- Motor wiring knockouts or access panels are provided at the base of IP21 (NEMA1/12) and higher units.
- Do not wire a starting or pole-changing device (for example Dahlander motor or slip ring asynchronous motor) between the frequency converter and the motor.

Procedure for grounding the cable shield

1. Strip a section of the outer cable insulation.
2. Position the stripped wire under the cable clamp to establish mechanical fixation and electrical contact between the cable shield and ground.
3. Connect the ground wire to the nearest grounding terminal in accordance with the grounding instructions provided in *chapter 4.3 Grounding*, see *Illustration 4.6*.
4. Connect the 3-phase motor wiring to terminals 96 (U), 97 (V), and 98 (W), see *Illustration 4.6*.
5. Tighten the terminals in accordance with the information provided in *chapter 8.7 Connection Tightening Torques*.

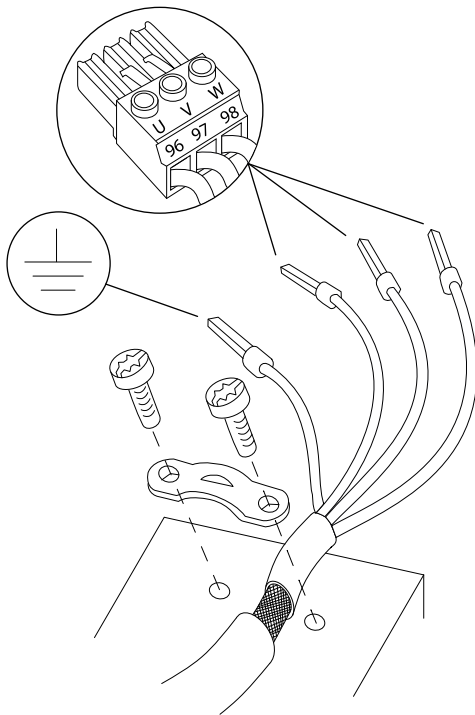

130BD531.10

Illustration 4.6 Motor Connection

Illustration 4.7 shows mains input, motor, and grounding for basic frequency converters. Actual configurations vary with unit types and optional equipment.

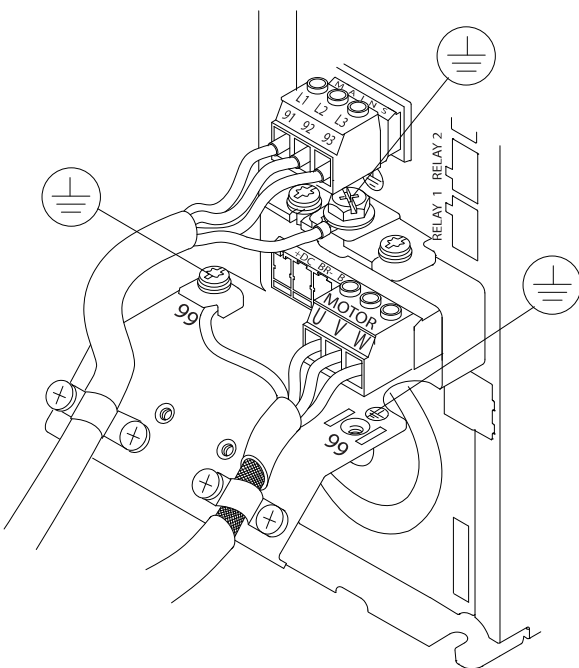

130BF048.11

Illustration 4.7 Example of Motor, Mains, and Ground Wiring

4.7 AC Mains Connection

- Size the wiring based on the input current of the frequency converter. For maximum wire sizes, see *chapter 8.1 Electrical Data*.
- Comply with local and national electrical codes for cable sizes.

Procedure

1. Connect the 3-phase AC input power wiring to terminals L1, L2, and L3 (see *Illustration 4.7*).
2. Depending on the configuration of the equipment, connect the input power to the mains input terminals or the input disconnect.
3. Ground the cable in accordance with the grounding instructions provided in *chapter 4.3 Grounding*.
4. When supplied from an isolated mains source (IT mains or floating delta) or TT/TN-S mains with a grounded leg (grounded delta), ensure that *parameter 14-50 RFI Filter* is set to [0] Off. This setting prevents damage to the DC link and reduces ground capacity currents in accordance with IEC 61800-3.

4.8 Control Wiring

- Isolate the control wiring from the high-power components in the frequency converter.
- When the frequency converter is connected to a thermistor, ensure that the thermistor control wiring is shielded and reinforced/double insulated. A 24 V DC supply voltage is recommended. See *Illustration 4.8*.

4.8.1 Control Terminal Types

Illustration 4.8 and Illustration 4.9 show the removable frequency converter connectors. Terminal functions and default settings are summarized in *Table 4.2*.

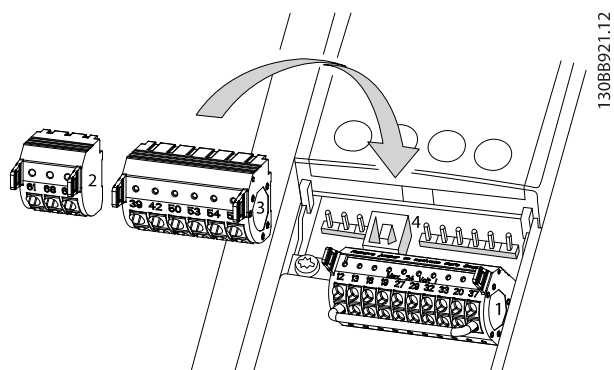

130BB921.12

Illustration 4.8 Control Terminal Locations

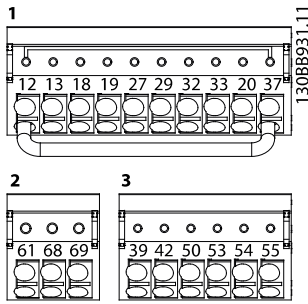

Illustration 4.9 Terminal Numbers

- **Connector 1** provides:
 - 4 programmable digital inputs terminals.
 - 2 extra digital terminals programmable as either input or output.
 - 24 V DC terminal supply voltage.
 - Optional customer supplied 24 V DC voltage.
- **Connector 2** terminals (+)68 and (-)69 are for an RS485 serial communication connection.
- **Connector 3** provides:
 - 2 analog inputs.
 - 1 analog output.
 - 10 V DC supply voltage.
 - Commons for the inputs and output.
- **Connector 4** is a USB port available for use with the MCT 10 Set-up Software.

Terminal description			
Terminal	Parameter	Default setting	Description
Digital Inputs/Outputs			
12, 13	–	+24 V DC	24 V DC supply voltage for digital inputs and external transducers. Maximum output current 200 mA for all 24 V loads.
18	Parameter 5 -10 Terminal 18 Digital Input	[8] Start	Digital inputs.
19	Parameter 5 -11 Terminal 19 Digital Input	[0] No operation	
32	Parameter 5 -14 Terminal 32 Digital Input	[0] No operation	
33	Parameter 5 -15 Terminal 33 Digital Input	[0] No operation	
27	Parameter 5 -12 Terminal 27 Digital Input	[2] Coast inverse	For digital input or output. Default setting is input.
29	Parameter 5 -13 Terminal 29 Digital Input	[14] Jog	
20	–	–	Common for digital inputs and 0 V potential for 24 V supply.
37	–	Safe Torque Off (STO)	Safe input (optional). Used for STO.
Analog Inputs/Outputs			
39	–	–	Common for analog output
42	Parameter 6 -50 Terminal 42 Output	Speed 0 – High Limit	Programmable analog output. 0–20 mA or 4–20 mA at a maximum of 500 Ω
50	–	+10 V DC	10 V DC analog supply voltage for potentiometer or thermistor. 15 mA maximum

Terminal description			
Terminal	Parameter	Default setting	Description
53	Parameter group 6-1* Analog Input 53	Reference	Analog input. For voltage or current. Switches A53 and A54 select mA or V.
	54	Parameter group 6-2* Analog Input 54	
55	-	-	Common for analog input
Serial Communication			
61	-	-	Integrated RC-Filter for cable shield. ONLY for connecting the shield if EMC problems occur.
68 (+) 69 (-)	Parameter group 8-3* FC Port Settings	-	RS485 Interface. A control card switch is provided for termination resistance.
	Parameter group 8-3* FC Port Settings	-	
Relays			
01, 02, 03 04, 05, 06	Parameter 5 -40 Function Relay [0]	[9] Alarm	Form C relay output. For AC or DC voltage and resistive or inductive loads.
	Parameter 5 -40 Function Relay [1]	[5] Running	

Table 4.2 Terminal Description

Extra terminals

- 2 form C relay outputs. Location of the outputs depends on frequency converter configuration.
- Terminals on built-in optional equipment. See the manual provided with the equipment option.

4.8.2 Wiring to Control Terminals

Control terminal connectors can be unplugged from the frequency converter for ease of installation, as shown in Illustration 4.10.

NOTICE

Keep control wires as short as possible and separate from high-power cables to minimize interference.

1. For flexible wires: Open the contact by inserting a flathead screwdriver (maximum head width: 4 mm, respectively no. 1) into the slot in the

middle between the 2 contacts and push the screwdriver slightly upwards.

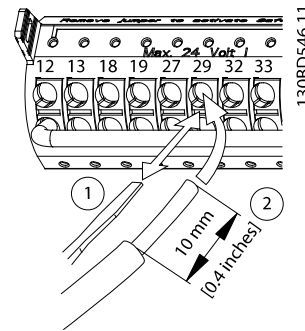

Illustration 4.10 Connecting Control Wires

2. Insert the bare control wire into the contact.
3. For flexible wires: Remove the screwdriver to fasten the control wire into the contact.
4. Ensure that the contact is firmly established and not lose. Loose control wiring can be the source of equipment faults or less than optimal operation.
5. To remove a control wire:
 - 5a Open the contact by inserting a flathead screwdriver (maximum head width: 4 mm, respectively no. 1) into the slot in the middle between the 2 contacts and push the screwdriver slightly upwards.
 - 5b Remove the control wire from the contact.
 - 5c Remove the screwdriver.

See chapter 8.5 Cable Specifications for control terminal wiring sizes and chapter 6 Application Set-up Examples for typical control wiring connections.

4.8.3 Enabling Motor Operation (Terminal 27)

A jumper wire is required between terminal 12 (or 13) and terminal 27 for the frequency converter to operate when using factory default programming values.

- Digital input terminal 27 is designed to receive 24 V DC external interlock command.
- When no interlock device is used, wire a jumper between control terminal 12 (recommended) or 13 to terminal 27. The jumper provides an internal 24 V signal on terminal 27.
- When the status line at the bottom of the LCP reads *AUTO REMOTE COAST*, it indicates that the unit is ready to operate but is missing an input signal on terminal 27.

4

- When factory installed optional equipment is wired to terminal 27:
 - Do not remove that wiring.
 - Do not add a jumper between terminals 12 and 27.
 - Do not disable input 27.

NOTICE

UNABLE TO START

The frequency converter cannot operate without a signal on terminal 27, unless terminal 27 is reprogrammed to “No operation”.

4.8.4 Voltage/Current Input Selection (Switches)

The analog input terminals 53 and 54 allow setting of input signal to voltage (0–10 V) or current (0/4–20 mA).

Default parameter setting

- Terminal 53: Speed reference signal in open loop (see *parameter 16-61 Terminal 53 Switch Setting*).
- Terminal 54: Feedback signal in closed loop (see *parameter 16-63 Terminal 54 Switch Setting*).

NOTICE

Disconnect power to the frequency converter before changing switch positions.

1. Remove the LCP (see *Illustration 4.11*).
2. Remove any optional equipment covering the switches.
3. Set switches A53 and A54 to select the signal type. U selects voltage, I selects current.

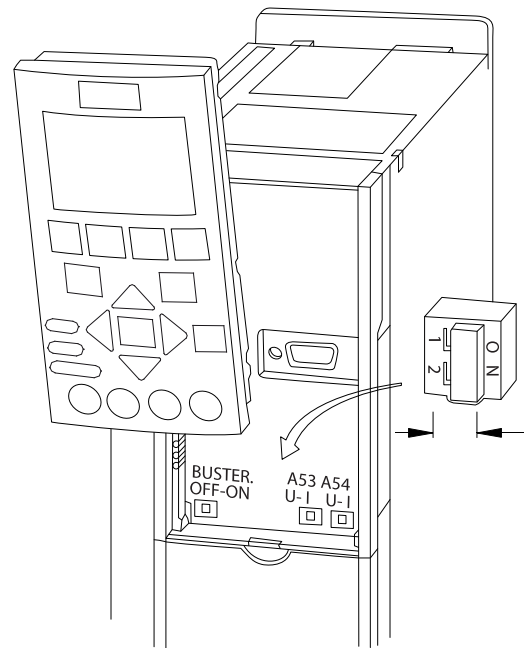

130BD530.10

Illustration 4.11 Location of Terminal 53 and 54 Switches

4.8.5 Safe Torque Off (STO)

To run STO, more wiring for the frequency converter is required. Refer to *Safe Torque Off Operating Guide* for further information.

4.8.6 RS485 Serial Communication

Connect RS485 serial communication wiring to terminals (+)68 and (-)69.

- Use shielded serial communication cable (recommended).
- See *chapter 4.3 Grounding* for proper grounding.

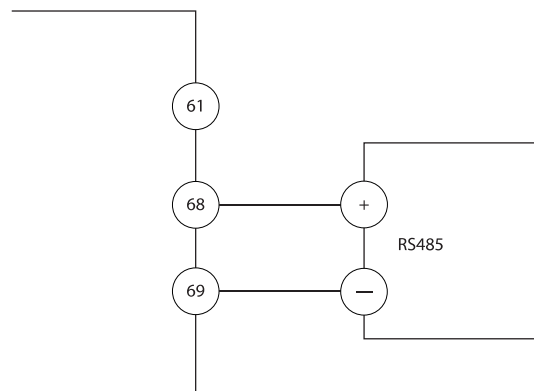

130BB489.10

Illustration 4.12 Serial Communication Wiring Diagram

For basic serial communication set-up, select the following:

1. Protocol type in *parameter 8-30 Protocol*.
 2. Frequency converter address in *parameter 8-31 Address*.
 3. Baud rate in *parameter 8-32 Baud Rate*.
- 2 communication protocols are internal to the frequency converter:
 - Wilo FC.
 - Modbus RTU.
 - Functions can be programmed remotely using the protocol software and RS485 connection or in *parameter group 8-** Communications and Options*.
 - Selecting a specific communication protocol changes various default parameter settings to match the specifications of that protocol and makes more protocol-specific parameters available.
 - Option cards for the frequency converter are available to provide extra communication protocols. See the option card documentation for installation and operation instructions.

4.9 Installation Check List

Before completing installation of the unit, inspect the entire installation as detailed in *Table 4.3*. Check and mark the items when completed.

4

Inspect for	Description	<input checked="" type="checkbox"/>
Auxiliary equipment	<ul style="list-style-type: none"> Look for auxiliary equipment, switches, disconnects, or input fuses/circuit breakers, residing on the input power side of the frequency converter, or output side to the motor. Ensure that they are ready for full-speed operation. Check the function and installation of any sensors used for feedback to the frequency converter. Remove any power factor correction caps on the motor. Adjust any power factor correction caps on the mains side and ensure that they are dampened. 	
Cable routing	<ul style="list-style-type: none"> Ensure that the motor wiring and control wiring are separated, shielded, or in 3 separate metallic conduits for high frequency interference isolation. 	
Control wiring	<ul style="list-style-type: none"> Check for broken or damaged wires and loose connections. Check that the control wiring is isolated from power and motor wiring for noise immunity. Check the voltage source of the signals, if necessary. <p>The use of shielded cable or twisted pair is recommended. Ensure that the shield is terminated correctly.</p>	
Cooling clearance	<ul style="list-style-type: none"> Ensure that the top and bottom clearance is adequate to ensure proper airflow for cooling, see <i>chapter 3.3 Mounting</i>. 	
Ambient conditions	<ul style="list-style-type: none"> Check that requirements for ambient conditions are met. 	
Fusing and circuit breakers	<ul style="list-style-type: none"> Check for proper fusing or circuit breakers. Check that all fuses are inserted firmly and are in operational condition, and that all circuit breakers are in the open position. 	
Grounding	<ul style="list-style-type: none"> Check for sufficient ground connections and ensure that those connections are tight and free of oxidation. Grounding to conduit, or mounting the back panel to a metal surface, is not a suitable grounding. 	
Input and output power wiring	<ul style="list-style-type: none"> Check for loose connections. Check that the motor and mains cables are in separate conduit or separated shielded cables. 	
Panel interior	<ul style="list-style-type: none"> Inspect that the unit interior is free of dirt, metal chips, moisture, and corrosion. Check that the unit is mounted on an unpainted metal surface. 	
Switches	<ul style="list-style-type: none"> Ensure that all switch and disconnect settings are in the proper positions. 	
Vibration	<ul style="list-style-type: none"> Check that the unit is mounted solidly, or that shock mounts are used, as necessary. Check for an unusual amount of vibration. 	

Table 4.3 Installation Check List

CAUTION

POTENTIAL HAZARD IN THE EVENT OF INTERNAL FAILURE

Risk of personal injury if the frequency converter is not properly closed.

- Before applying power, ensure that all safety covers are in place and securely fastened.

5 Commissioning

5.1 Safety Instructions

See *chapter 2 Safety* for general safety instructions.

WARNING

HIGH VOLTAGE

Frequency converters contain high voltage when connected to AC mains input power. Failure to perform installation, start-up, and maintenance by qualified personnel could result in death or serious injury.

- Installation, start-up, and maintenance must be performed by qualified personnel only.

NOTICE

The front covers with warning signs are an integrated part of the frequency converter and considered safety covers. The covers must be in place before applying power and at all times.

Before applying power:

1. Close the safety cover properly.
2. Check that all cable glands are firmly tightened.
3. Ensure that input power to the unit is off and locked out. Do not rely on the frequency converter disconnect switches for input power isolation.
4. Verify that there is no voltage on input terminals L1 (91), L2 (92), and L3 (93), phase-to-phase, and phase-to-ground.
5. Verify that there is no voltage on output terminals 96 (U), 97 (V), and 98 (W), phase-to-phase, and phase-to-ground.
6. Confirm continuity of the motor by measuring Ω values on U–V (96–97), V–W (97–98), and W–U (98–96).
7. Check for proper grounding of the frequency converter and the motor.
8. Inspect the frequency converter for loose connections on the terminals.
9. Confirm that the supply voltage matches the voltage of the frequency converter and the motor.

5.2 Applying Power

Apply power to the frequency converter using the following steps:

1. Confirm that the input voltage is balanced within 3%. If not, correct the input voltage imbalance before proceeding. Repeat this procedure after the voltage correction.
2. Ensure that any optional equipment wiring matches the installation application.
3. Ensure that all operator devices are in the OFF position. Panel doors must be closed and covers securely fastened.
4. Apply power to the unit. Do not start the frequency converter now. For units with a disconnect switch, turn it to the ON position to apply power to the frequency converter.

5.3 Local Control Panel Operation

The local control panel (LCP) is the combined display and keypad on the front of the unit.

The LCP has several user functions:

- Start, stop, and control speed when in local control.
- Show operational data, status, warnings, and cautions.
- Program frequency converter functions.
- Manually reset the frequency converter after a fault when auto reset is inactive.

NOTICE

For commissioning via PC, install the MCT 10 Set-up Software. For more information and downloads, contact WIL0 SE.

5.3.1 Graphic Local Control Panel Layout

The graphic local control panel (GLCP) is divided into 4 functional groups (see *Illustration 5.1*).

- A. Display area.
- B. Display menu keys.
- C. Navigation keys and indicator lights.
- D. Operation keys and reset.

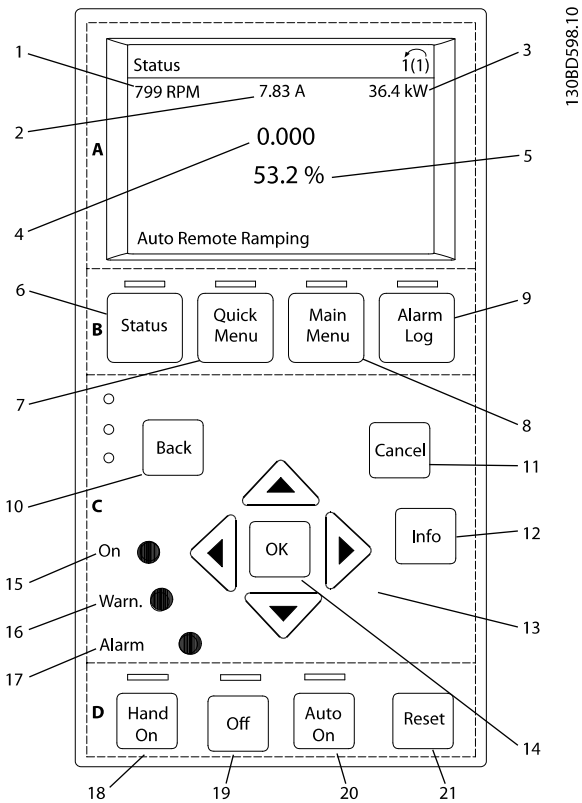

Illustration 5.1 GLCP

A. Display area

The display area is activated when the frequency converter receives power from the mains voltage, a DC bus terminal, or a 24 V DC external supply.

The information shown on the LCP can be customized for user applications. Select options in the *Quick Menu Q3-13 Display Settings*.

Display	Parameter	Default setting
1	Parameter 0-20 Display Line 1.1 Small	[1617] Speed [RPM]
2	Parameter 0-21 Display Line 1.2 Small	[1614] Motor Current
3	Parameter 0-22 Display Line 1.3 Small	[1610] Power [kW]
4	Parameter 0-23 Display Line 2 Large	[1613] Frequency
5	Parameter 0-24 Display Line 3 Large	[1602] Reference %

Table 5.1 Legend to Illustration 5.1, Display Area

B. Display menu keys

Menu keys are used for menu access for parameter set-up, toggling through status display modes during normal operation, and viewing fault log data.

	Key	Function
6	Status	Shows operational information.
7	Quick Menu	Allows access to programming parameters for initial set-up instructions and many detailed application instructions.
8	Main Menu	Allows access to all programming parameters.
9	Alarm Log	Shows a list of current warnings, the last 10 alarms, and the maintenance log.

Table 5.2 Legend to Illustration 5.1, Display Menu Keys

C. Navigation keys and indicator lights (LEDs)

Navigation keys are used for programming functions and moving the display cursor. The navigation keys also provide speed control in local operation. There are also 3 frequency converter status indicator lights in this area.

	Key	Function
10	Back	Reverts to the previous step or list in the menu structure.
11	Cancel	Cancels the last change or command as long as the display mode is not changed.
12	Info	Press for a definition of the function being showed.
13	Navigation Keys	Press the navigation keys to move between items in the menu.
14	OK	Press to access parameter groups or to enable a selection.

Table 5.3 Legend to Illustration 5.1, Navigation Keys

	Indicator	Color	Function
15	On	Green	The ON indicator light activates when the frequency converter receives power from the mains voltage, a DC bus terminal, or a 24 V external supply.
16	Warn	Yellow	When warning conditions are met, the yellow WARN indicator light comes on and text appears in the display area identifying the problem.
17	Alarm	Red	A fault condition causes the red alarm LED to flash and an alarm text is shown.

Table 5.4 Legend to Illustration 5.1, Indicator Lights (LEDs)

D. Operation keys and reset

Operation keys are at the bottom of the LCP.

	Key	Function
18	[Hand On]	Starts the frequency converter in local control. <ul style="list-style-type: none"> An external stop signal by control input or serial communication overrides the local hand on.
19	Off	Stops the motor but does not remove power to the frequency converter.
20	[Auto On]	Puts the system in remote operational mode. <ul style="list-style-type: none"> Responds to an external start command by control terminals or serial communication.
21	Reset	Resets the frequency converter manually after a fault has been cleared.

Table 5.5 Legend to *Illustration 5.1, Operation Keys and Reset*

NOTICE

To adjust the display contrast, press [Status] and the [▲]/[▼] keys.

5.3.2 Parameter Settings

Establishing the correct programming for applications often requires setting functions in several related parameters. Details for parameters are provided in *chapter 9.2 Parameter Menu Structure*.

Programming data is stored internally in the frequency converter.

- For back-up, upload data into the LCP memory.
- To download data to another frequency converter, connect the LCP to that unit and download the stored settings.
- Restoring factory default settings does not change data stored in the LCP memory.

5.3.3 Uploading/Downloading Data to/from the LCP

1. Press [Off] to stop the motor before uploading or downloading data.
2. Press [Main Menu], select *parameter 0-50 LCP Copy* and press [OK].
3. Select [1] *All to LCP* to upload data to the LCP or select [2] *All from LCP* to download data from the LCP.
4. Press [OK]. A progress bar shows the uploading or downloading progress.

5. Press [Hand On] or [Auto On] to return to normal operation.

5.3.4 Changing Parameter Settings

Access and change parameter settings from the *Quick Menu* or from the *Main Menu*. The *Quick Menu* only gives access to a limited number of parameters.

1. Press [Quick Menu] or [Main Menu] on the LCP.
2. Press [▲] [▼] to browse through the parameter groups, press [OK] to select a parameter group.
3. Press [▲] [▼] to browse through the parameters, press [OK] to select a parameter.
4. Press [▲] [▼] to change the value of a parameter setting.
5. Press [◀] [▶] to shift digit when a decimal parameter is in the editing state.
6. Press [OK] to accept the change.
7. Press either [Back] twice to enter *Status*, or press [Main Menu] once to enter the *Main Menu*.

View changes

Quick Menu Q5 - Changes Made lists all parameters changed from default settings.

- The list only shows parameters, which are changed in the current edit set-up.
- Parameters, which were reset to default values, are not listed.
- The message *Empty* indicates that no parameters are changed.

5.3.5 Restoring Default Settings

NOTICE

Risk of losing programming, motor data, localization, and monitoring records by restoration of default settings. To provide a back-up, upload data to the LCP before initialization.

Restoring the default parameter settings is done by initialization of the frequency converter. Initialization is carried out through *parameter 14-22 Operation Mode* (recommended) or manually.

- Initialization using *parameter 14-22 Operation Mode* does not reset the frequency converter settings such as hours run, serial communication selections, personal menu settings, fault log, alarm log, and other monitoring functions.
- Manual initialization erases all motor, programming, localization, and monitoring data, and restores factory default settings.

Recommended initialization procedure via parameter 14-22 Operation Mode

1. Press [Main Menu] twice to access parameters.
2. Scroll to *parameter 14-22 Operation Mode* and press [OK].
3. Scroll to [2] *initialization* and press [OK].
4. Remove power to the unit and wait for the display to turn off.
5. Apply power to the unit.

Default parameter settings are restored during start-up. The start-up may take slightly longer than normal.

6. *Alarm 80, Drive initialized to default value* is shown.
7. Press [Reset] to return to operating mode.

Manual initialization procedure

1. Remove power to the unit and wait for the display to turn off.
2. Press and hold [Status], [Main Menu], and [OK] at the same time while applying power to the unit (approximately 5 s or until audible click and fan starts).

Factory default parameter settings are restored during start-up. The start-up may take slightly longer than usual.

Manual initialization does not reset the following frequency converter information:

- *Parameter 15-00 Operating hours.*
- *Parameter 15-03 Power Up's.*
- *Parameter 15-04 Over Temp's.*
- *Parameter 15-05 Over Volt's.*

5.4 Basic Programming

5.4.1 Commissioning with SmartStart

The SmartStart wizard enables fast configuration of basic motor and application parameters.

- SmartStart starts automatically at first power-up or after initialization of the frequency converter.
- Follow the on-screen instructions to complete the commissioning of the frequency converter. Always reactivate SmartStart by selecting *Quick Menu Q4 - SmartStart*.
- For commissioning without use of the SmartStart wizard, refer to *chapter 5.4.2 Commissioning via [Main Menu]* or the programming guide.

NOTICE

Motor data is required for the SmartStart set-up. The required data is normally available on the motor nameplate.

The SmartStart configures the frequency converter in 3 phases, each consisting of several steps, see *Table 5.6*.

Phase		Action
1	Basic Programming	Perform the programming
2	Application Section	Select and program appropriate application: <ul style="list-style-type: none"> • Single pump/motor. • Motor alternation. • Basic cascade control. • Master/slave.
3	Water and Pump Features	Go to water and pump dedicated parameters.

Table 5.6 SmartStart, Setup in 3 Phases

5.4.2 Commissioning via [Main Menu]

Recommended parameter settings are intended for start-up and check-out purposes. Application settings may vary.

Enter data with power ON, but before operating the frequency converter.

1. Press [Main Menu] on the LCP.
2. Press the navigation keys to scroll to *parameter group 0-** Operation/Display* and press [OK].

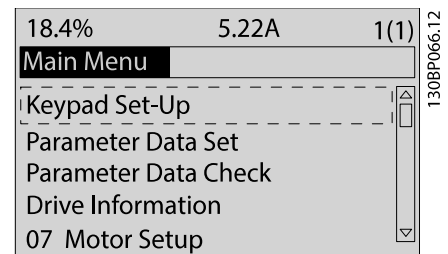

Illustration 5.2 Main Menu

3. Press the navigation keys to scroll to *parameter group 0-0* Basic Settings* and press [OK].

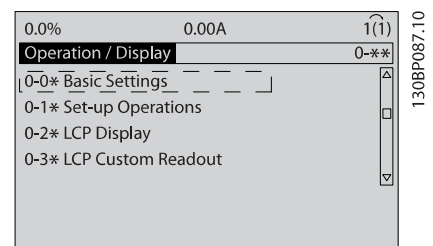

Illustration 5.3 Operation/Display

4. Press the navigation keys to scroll to *parameter 0-03 Regional Settings* and press [OK].

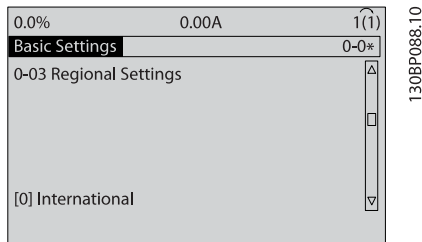

Illustration 5.4 Basic Settings

5. Press the navigation keys to select *[0] International* or *[1] North America* as appropriate and press [OK]. (This changes the default settings for several basic parameters).
6. Press [Main Menu] on the LCP.
7. Press the navigation keys to scroll to *parameter 0-01 Language*.
8. Select the language and press [OK].
9. If a jumper wire is in place between control terminals 12 and 27, leave *parameter 5-12 Terminal 27 Digital Input* at factory default. Otherwise, select *[0] No operation* in *parameter 5-12 Terminal 27 Digital Input*.
10. Make the application-specific settings in the following parameters:
 - 10a *Parameter 3-02 Minimum Reference*.
 - 10b *Parameter 3-03 Maximum Reference*.
 - 10c *Parameter 3-41 Ramp 1 Ramp Up Time*.
 - 10d *Parameter 3-42 Ramp 1 Ramp Down Time*.
 - 10e *Parameter 3-13 Reference Site*. Linked to Hand/Auto Local Remote.

5.4.3 Asynchronous Motor Set-up

Enter the following motor data. Find the information on the motor nameplate.

1. *Parameter 1-20 Motor Power [kW]* or *parameter 1-21 Motor Power [HP]*.
2. *Parameter 1-22 Motor Voltage*.
3. *Parameter 1-23 Motor Frequency*.
4. *Parameter 1-24 Motor Current*.
5. *Parameter 1-25 Motor Nominal Speed*.

For optimum performance in VVC⁺ mode, extra motor data is required to set up the following parameters. Find the data in the motor datasheet (this data is typically not

available on the motor nameplate). Run a complete automatic motor adaptation (AMA) using *parameter 1-29 Automatic Motor Adaptation (AMA) [1] Enable Complete AMA* or enter the parameters manually. *Parameter 1-36 Iron Loss Resistance (Rfe)* is always entered manually.

6. *Parameter 1-30 Stator Resistance (Rs)*.
7. *Parameter 1-31 Rotor Resistance (Rr)*.
8. *Parameter 1-33 Stator Leakage Reactance (X1)*.
9. *Parameter 1-34 Rotor Leakage Reactance (X2)*.
10. *Parameter 1-35 Main Reactance (Xh)*.
11. *Parameter 1-36 Iron Loss Resistance (Rfe)*.

Application-specific adjustment when running VVC⁺

VVC⁺ is the most robust control mode. In most situations, it provides optimum performance without further adjustments. Run a complete AMA for best performance.

5.4.4 PM Motor Setup in VVC⁺

NOTICE

Only use permanent magnet (PM) motor with fans and pumps.

Initial programming steps

1. Activate PM motor operation *parameter 1-10 Motor Construction*, select *[1] PM, non salient SPM*.
2. Set *parameter 0-02 Motor Speed Unit* to *[0] RPM*.

Programming motor data

After selecting PM motor in *parameter 1-10 Motor Construction*, the PM motor-related parameters in parameter groups *1-2* Motor Data*, *1-3* Adv. Motor Data* and *1-4** are active. The necessary data can be found on the motor nameplate and in the motor datasheet.

Program the following parameters in the listed order:

1. *Parameter 1-24 Motor Current.*
2. *Parameter 1-26 Motor Cont. Rated Torque.*
3. *Parameter 1-25 Motor Nominal Speed.*
4. *Parameter 1-39 Motor Poles.*
5. *Parameter 1-30 Stator Resistance (Rs).*
Enter line to common stator winding resistance (Rs). If only line-line data is available, divide the line-line value with 2 to achieve the line to common (startpoint) value.
6. *Parameter 1-37 d-axis Inductance (Ld).*
Enter line to common direct axis inductance of the PM motor.
If only line-line data is available, divide the line-line value by 2 to achieve the line-common (startpoint) value.
7. *Parameter 1-40 Back EMF at 1000 RPM.*
Enter line-to-line back EMF of the PM motor at 1000 RPM mechanical speed (RMS value). Back EMF is the voltage generated by a PM motor when no frequency converter is connected and the shaft is turned externally. Back EMF is normally specified for nominal motor speed or for 1000 RPM measured between 2 lines. If the value is not available for a motor speed of 1000 RPM, calculate the correct value as follows: If back EMF is for example 320 V at 1800 RPM, it can be calculated at 1000 RPM as follows: Back EMF = (Voltage / RPM)*1000 = (320/1800)*1000 = 178. This is the value that must be programmed for *parameter 1-40 Back EMF at 1000 RPM.*

Test motor operation

1. Start the motor at low speed (100–200 RPM). If the motor does not turn, check installation, general programming, and motor data.
2. Check if the start function in *parameter 1-70 PM Start Mode* fits the application requirements.

Rotor detection

This function is the recommended choice for applications where the motor starts from standstill, for example pumps or conveyors. On some motors, a sound is heard when the impulse is sent out. This does not harm the motor.

Parking

This function is the recommended choice for applications where the motor is rotating at slow speed, for example windmilling in fan applications. *Parameter 2-06 Parking*

Current and *parameter 2-07 Parking Time* can be adjusted. Increase the factory setting of these parameters for applications with high inertia.

Start the motor at nominal speed. If the application does not run well, check the VVC+ PM settings. Recommended settings in different applications can be found in *Table 5.7*.

Application	Settings
Low inertia applications $I_{Load}/I_{Motor} < 5$	<i>Parameter 1-17 Voltage filter time const.</i> to be increased by factor 5–10. <i>Parameter 1-14 Damping Gain</i> should be reduced. <i>Parameter 1-66 Min. Current at Low Speed</i> should be reduced (<100%).
Low inertia applications $50 > I_{Load}/I_{Motor} > 5$	Keep calculated values.
High inertia applications $I_{Load}/I_{Motor} > 50$	<i>Parameter 1-14 Damping Gain</i> , <i>parameter 1-15 Low Speed Filter Time Const.</i> , and <i>parameter 1-16 High Speed Filter Time Const.</i> should be increased.
High load at low speed <30% (rated speed)	<i>Parameter 1-17 Voltage filter time const.</i> should be increased. <i>Parameter 1-66 Min. Current at Low Speed</i> should be increased (>100% for a prolonged time can overheat the motor).

Table 5.7 Recommended Settings in Different Applications

If the motor starts oscillating at a certain speed, increase *parameter 1-14 Damping Gain*. Increase the value in small steps. Depending on the motor, a good value for this parameter can be 10% or 100% higher than the default value.

The starting torque can be adjusted in *parameter 1-66 Min. Current at Low Speed*. 100% provides nominal torque as starting torque.

5.4.5 SynRM Motor Set-up with VVC+

This section describes how to set up a SynRM motor with VVC+.

NOTICE

The SmartStart wizard covers the basic configuration of SynRM motors.

Initial programming steps

To activate SynRM motor operation, select [5] *Sync. Reluctance* in *parameter 1-10 Motor Construction*.

Programming motor data

After performing the initial programming steps, the SynRM motor-related parameters in *parameter groups 1-2* Motor Data, 1-3* Adv. Motor Data, and 1-4* Adv. Motor Data II* are active.

Use the motor nameplate data and the motor datasheet to program the following parameters in the order listed:

1. *Parameter 1-23 Motor Frequency.*
2. *Parameter 1-24 Motor Current.*
3. *Parameter 1-25 Motor Nominal Speed.*
4. *Parameter 1-26 Motor Cont. Rated Torque.*

Run a complete AMA using *parameter 1-29 Automatic Motor Adaptation (AMA) [1] Enable Complete AMA* or enter the following parameters manually:

1. *Parameter 1-30 Stator Resistance (Rs).*
2. *Parameter 1-37 d-axis Inductance (Ld).*
3. *Parameter 1-44 d-axis Inductance Sat. (LdSat).*
4. *Parameter 1-45 q-axis Inductance Sat. (LqSat).*
5. *Parameter 1-48 Inductance Sat. Point.*

Application-specific adjustments

Start the motor at nominal speed. If the application does not run well, check the VVC+ SynRM settings. *Table 5.8* provides application-specific recommendations:

Application	Settings
Low-inertia applications $I_{Load}/I_{Motor} < 5$	Increase <i>parameter 1-17 Voltage filter time const.</i> by factor 5–10. Reduce <i>parameter 1-14 Damping Gain.</i> Reduce <i>parameter 1-66 Min. Current at Low Speed</i> (<100%).
Low-inertia applications $50 > I_{Load}/I_{Motor} > 5$	Keep the default values.
High-inertia applications $I_{Load}/I_{Motor} > 50$	Increase <i>parameter 1-14 Damping Gain</i> , <i>parameter 1-15 Low Speed Filter Time Const.</i> , and <i>parameter 1-16 High Speed Filter Time Const.</i>
High-load at low speed <30% (rated speed)	Increase <i>parameter 1-17 Voltage filter time const.</i> Increase <i>parameter 1-66 Min. Current at Low Speed</i> to adjust the starting torque. 100% current provides nominal torque as starting torque. Working at a current level higher than 100% for a prolonged time can cause the motor to overheat.

Application	Settings
Dynamic applications	Increase <i>parameter 14-41 AEO Minimum Magnetisation</i> for highly dynamic applications. Adjusting <i>parameter 14-41 AEO Minimum Magnetisation</i> ensures a good balance between energy efficiency and dynamics. Adjust <i>parameter 14-42 Minimum AEO Frequency</i> to specify the minimum frequency at which the frequency converter should use minimum magnetization.
Motor sizes less than 18 kW (24 hp)	Avoid short ramp-down times.

Table 5.8 Recommendations for Various Applications

If the motor starts oscillating at a certain speed, increase *parameter 1-14 Damping Gain*. Increase the damping gain value in small steps. Depending on the motor, this parameter can be set to 10–100% higher than the default value.

5.4.6 Automatic Energy Optimization (AEO)

NOTICE

AEO is not relevant for permanent magnet motors.

AEO is a procedure which minimizes voltage to the motor, as a result of that reducing energy consumption, heat, and noise.

To activate AEO, set *parameter 1-03 Torque Characteristics* to [2] *Auto Energy Optim. CT* or [3] *Auto Energy Optim. VT*.

5.4.7 Automatic Motor Adaptation (AMA)

AMA is a procedure which optimizes compatibility between the frequency converter and the motor.

- The frequency converter builds a mathematical model of the motor for regulating output motor current. The procedure also tests the input phase balance of electrical power. It compares the motor characteristics with the entered nameplate data.
- The motor shaft does not turn and no harm is done to the motor while running the AMA.
- Some motors may be unable to run the complete version of the test. In that case, select [2] *Enable reduced AMA*.
- If an output filter is connected to the motor, select [2] *Enable reduced AMA*.

- If warnings or alarms occur, see *chapter 7.4 List of Warnings and Alarms*.
- Run this procedure on a cold motor for best results.

To run AMA

1. Press [Main Menu] to access parameters.
2. Scroll to *parameter group 1-** Load and Motor* and press [OK].
3. Scroll to *parameter group 1-2* Motor Data* and press [OK].
4. Scroll to *parameter 1-29 Automatic Motor Adaptation (AMA)* and press [OK].
5. Select [1] *Enable complete AMA* and press [OK].
6. Follow the on-screen instructions.
7. The test runs automatically and indicates when it is complete.
8. The advanced motor data is entered in *parameter group 1-3* Adv. Motor Data*.

5.5 Checking Motor Rotation

NOTICE

Risk of damage to pumps/compressors caused by motor running in wrong direction. Before running the frequency converter, check the motor rotation.

The motor runs briefly at 5 Hz or the minimum frequency set in *parameter 4-12 Motor Speed Low Limit [Hz]*.

1. Press [Main Menu].
2. Scroll to *parameter 1-28 Motor Rotation Check* and press [OK].
3. Scroll to [1] *Enable*.

The following text appears: *Note! Motor may run in wrong direction.*

4. Press [OK].
5. Follow the on-screen instructions.

NOTICE

To change the direction of rotation, remove power to the frequency converter and wait for power to discharge. Reverse the connection of any 2 of the 3 motor wires on the motor or frequency converter side of the connection.

5.6 Local-control Test

1. Press [Hand On] to provide a local start command to the frequency converter.
2. Accelerate the frequency converter by pressing [▲] to full speed. Moving the cursor left of the decimal point provides quicker input changes.
3. Note any acceleration problems.

4. Press [Off]. Note any deceleration problems.

If acceleration or deceleration problems occur, see *chapter 7.5 Troubleshooting*. See *chapter 7.4 List of Warnings and Alarms* for resetting the frequency converter after a trip.

5.7 System Start-up

The procedure in this section requires wiring and application programming to be completed. The following procedure is recommended after application set-up is completed.

1. Press [Auto On].
2. Apply an external run command.
3. Adjust the speed reference throughout the speed range.
4. Remove the external run command.
5. Check the sound and vibration levels of the motor to ensure that the system is working as intended.

If warnings or alarms occur, see *chapter 7.3 Warning and Alarm Types* or *chapter 7.4 List of Warnings and Alarms*.

6 Application Set-up Examples

The examples in this section are intended as a quick reference for common applications.

- Parameter settings are the regional default values unless otherwise indicated (selected in *parameter 0-03 Regional Settings*).
- Parameters associated with the terminals and their settings are shown next to the drawings.
- Required switch settings for analog terminals A53 or A54 are also shown.

NOTICE

When using the optional Safe Torque Off (STO) feature, a jumper wire may be required between terminal 12 (or 13) and terminal 37 for the frequency converter to operate with factory default programming values.

6.1 Application Examples

6.1.1 Feedback

		Parameters	
		Function	Setting
		<i>Parameter 6-22 Terminal 54 Low Current</i>	4 mA*
		<i>Parameter 6-23 Terminal 54 High Current</i>	20 mA*
		<i>Parameter 6-24 Terminal 54 Low Ref./Feedb. Value</i>	0*
		<i>Parameter 6-25 Terminal 54 High Ref./Feedb. Value</i>	50*
	* = Default value		
	Notes/comments: D IN 37 is an option.		
	 A 54		
	 A 54		
	 A 54		
	 A 54		

Table 6.1 Analog Current Feedback Transducer

		Parameters	
		Function	Setting
		<i>Parameter 6-20 Terminal 54 Low Voltage</i>	0.07 V*
		<i>Parameter 6-21 Terminal 54 High Voltage</i>	10 V*
		<i>Parameter 6-24 Terminal 54 Low Ref./Feedb. Value</i>	0*
		<i>Parameter 6-25 Terminal 54 High Ref./Feedb. Value</i>	50*
	* = Default value		
	Notes/comments: D IN 37 is an option.		
	 A 54		
	 A 54		
	 A 54		
	 A 54		

Table 6.2 Analog Voltage Feedback Transducer (3-wire)

FC		Parameters		
		Function	Setting	
+24 V	12	130BB677.10 Voltage	Parameter 6-20 Terminal 54 Low Voltage	0.07 V*
+24 V	13		Parameter 6-21 Terminal 54 High Voltage	10 V*
D IN	18		Parameter 6-24 Terminal 54 Low Ref./Feedb. Value	0*
D IN	19		Parameter 6-25 Terminal 54 High Ref./Feedb. Value	50*
COM	20		* = Default value	
D IN	27	Notes/comments: D IN 37 is an option.		
D IN	29			
D IN	32			
D IN	33			
D IN	37			
+10 V	50	e30bb927.11 Current	Parameter 6-12 Terminal 53 Low Current	4 mA*
A IN	53		Parameter 6-13 Terminal 53 High Current	20 mA*
A IN	54		Parameter 6-14 Terminal 53 Low Ref./Feedb. Value	0 Hz
COM	55		Parameter 6-15 Terminal 53 High Ref./Feedb. Value	50 Hz
A OUT	42		* = Default value	
COM	39	Notes/comments: D IN 37 is an option.		

Table 6.3 Analog Voltage Feedback Transducer (4-wire)

6.1.2 Speed

FC		Parameters		
		Function	Setting	
+10 V	50	e30bb926.11 Voltage	Parameter 6-10 Terminal 53 Low Voltage	0.07 V*
A IN	53		Parameter 6-11 Terminal 53 High Voltage	10 V*
A IN	54	e30bb683.11 Voltage	Parameter 6-14 Terminal 53 Low Ref./Feedb. Value	0 Hz
COM	55		Parameter 6-15 Terminal 53 High Ref./Feedb. Value	50 Hz
A OUT	42	* = Default value		
COM	39	Notes/comments: D IN 37 is an option.		

Table 6.4 Analog Speed Reference (Voltage)

FC		Parameters		
		Function	Setting	
+10 V	50	e30bb927.11 Current	Parameter 6-12 Terminal 53 Low Current	4 mA*
A IN	53		Parameter 6-13 Terminal 53 High Current	20 mA*
A IN	54	e30bb683.11 Voltage	Parameter 6-14 Terminal 53 Low Ref./Feedb. Value	0 Hz
COM	55		Parameter 6-15 Terminal 53 High Ref./Feedb. Value	50 Hz
A OUT	42	* = Default value		
COM	39	Notes/comments: D IN 37 is an option.		

Table 6.5 Analog Speed Reference (Current)

FC		Parameters		
		Function	Setting	
+10 V	50	e30bb926.11 Voltage	Parameter 6-10 Terminal 53 Low Voltage	0.07 V*
A IN	53		Parameter 6-11 Terminal 53 High Voltage	10 V*
A IN	54	e30bb683.11 Voltage	Parameter 6-14 Terminal 53 Low Ref./Feedb. Value	0 Hz
COM	55		Parameter 6-15 Terminal 53 High Ref./Feedb. Value	50 Hz
A OUT	42	* = Default value		
COM	39	Notes/comments: D IN 37 is an option.		

Table 6.6 Speed Reference (Using a Manual Potentiometer)

6.1.3 Run/Stop

		Parameters	
FC		Function	Setting
+24 V	12	Parameter 5-10 Terminal 18 Digital Input	[8] Start*
+24 V	13		
D IN	18	Parameter 5-12 Terminal 27 Digital Input	[7] External interlock
D IN	19		
COM	20	* = Default value	
D IN	27	Notes/comments: D IN 37 is an option.	
D IN	29		
D IN	32		
D IN	33		
D IN	37		
+10 V	50		
A IN	53		
A IN	54		
COM	55		
A OUT	42		
COM	39		

Table 6.7 Run/Stop Command with External Interlock

		Parameters	
FC		Function	Setting
+24 V	12	Parameter 5-10 Terminal 18 Digital Input	[8] Start*
+24 V	13		
D IN	18	Parameter 5-11 Terminal 19 Digital Input	[52] Run Permissive
D IN	19		
COM	20	* = Default value	
D IN	27	Notes/comments: D IN 37 is an option.	
D IN	29		
D IN	32		
D IN	33		
D IN	37		
+10 V	50		
A IN	53		
A IN	54		
COM	55		
A OUT	42		
COM	39		

Table 6.9 Run Permissive

		Parameters	
FC		Function	Setting
+24 V	12	Parameter 5-10 Terminal 18 Digital Input	[8] Start*
+24 V	13		
D IN	18	Parameter 5-12 Terminal 27 Digital Input	[7] External interlock
D IN	19		
COM	20	* = Default value	
D IN	27	Notes/comments: If parameter 5-12 Terminal 27 Digital Input is set to [0] No operation, a jumper wire to terminal 27 is not needed. D IN 37 is an option.	
D IN	29		
D IN	32		
D IN	33		
D IN	37		
+10 V	50		
A IN	53		
A IN	54		
COM	55		
A OUT	42		
COM	39		

Table 6.8 Run/Stop Command without External Interlock

6.1.4 External Alarm Reset

		Parameters	
FC		Function	Setting
+24 V	12	Parameter 5-11 Terminal 19 Digital Input	[1] Reset
+24 V	13		
D IN	18	* = Default value	
D IN	19	Notes/comments: D IN 37 is an option.	
COM	20		
D IN	27		
D IN	29		
D IN	32		
D IN	33		
D IN	37		
+10 V	50		
A IN	53		
A IN	54		
COM	55		
A OUT	42		
COM	39		

Table 6.10 External Alarm Reset

6.1.5 RS485

		Parameters	
		Function	Setting
		Parameter 8-30 Protocol	FC*
		Parameter 8-31 Address	1*
		Parameter 8-32 Baud Rate	9600*
		* = Default value	
Notes/comments: Select protocol, address, and baud rate in the above-mentioned parameters. D IN 37 is an option.			

Table 6.11 RS485 Network Connection

6.1.6 Motor Thermistor

CAUTION

THERMISTOR INSULATION

Risk of personal injury or equipment damage.

- Use only thermistors with reinforced or double insulation to meet PELV insulation requirements.

		Parameters	
		Function	Setting
		Parameter 1-90 Motor Thermal Protection	[2] Thermistor trip
		Parameter 1-93 Thermistor Source	[1] Analog input 53
* = Default value			
Notes/comments: If only a warning is required, set parameter 1-90 Motor Thermal Protection to [1] Thermistor warning. D IN 37 is an option.			

Table 6.12 Motor Thermistor

7 Maintenance, Diagnostics, and Troubleshooting

This chapter includes:

- Maintenance and service guidelines.
- Status messages.
- Warnings and alarms.
- Basic troubleshooting.

7.1 Maintenance and Service

Under normal operating conditions and load profiles, the frequency converter is maintenance-free throughout its designed lifetime. To prevent breakdown, danger, and damage, examine the frequency converter for terminal connections tightness, dust entry, and so on at regular intervals depending on the operating conditions. Replace worn or damaged parts with original spare parts or standard parts. For service and support, contact the local Wilo supplier.

⚠ WARNING

UNINTENDED START

When the frequency converter is connected to AC mains, DC supply, or load sharing, the motor may start at any time. Unintended start during programming, service, or repair work can result in death, serious injury, or property damage. The motor can start via an external switch, a fieldbus command, an input reference signal from the LCP or LOP, via remote operation using MCT 10 Set-up Software, or after a cleared fault condition.

7.2 Status Messages

When the frequency converter is in *Status* mode, status messages are generated automatically and appear in the bottom line of the display (see *Illustration 7.1*).

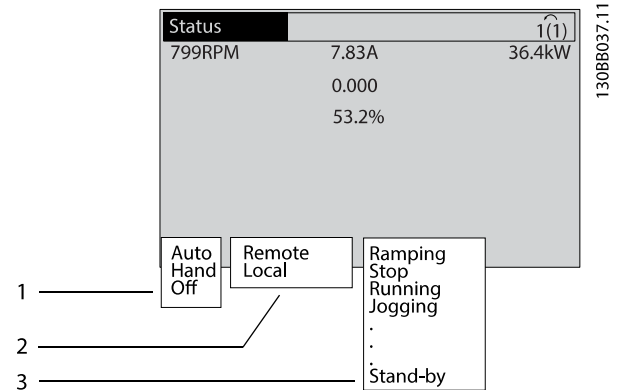

1	Operating mode (see <i>Table 7.1</i>)
2	Reference site (see <i>Table 7.2</i>)
3	Operation status (see <i>Table 7.3</i>)

Illustration 7.1 Status Display

Table 7.1 to *Table 7.3* describe the status messages shown.

Off	The frequency converter does not react to any control signal until [Auto On] or [Hand On] is pressed.
Auto On	The frequency converter is controlled from the control terminals and/or the serial communication.
Hand On	Control the frequency converter via the navigation keys on the LCP. Stop commands, reset, reversing, DC brake, and other signals applied to the control terminals override local control.

Table 7.1 Operating Mode

Remote	The speed reference is given from external signals, serial communication, or internal preset references.
Local	The frequency converter uses [Hand On] control or reference values from the LCP.

Table 7.2 Reference Site

AC Brake	[2] AC brake is selected in <i>parameter 2-10 Brake Function</i> . The AC brake overmagnetizes the motor to achieve a controlled slow down.
AMA finish OK	AMA was carried out successfully.
AMA ready	AMA is ready to start. Press [Hand On] to start.
AMA running	AMA process is in progress.
Braking	The brake chopper is in operation. Generative energy is absorbed by the brake resistor.

Braking max.	The brake chopper is in operation. The power limit for the brake resistor defined in <i>parameter 2-12 Brake Power Limit (kW)</i> has been reached.
Coast	<ul style="list-style-type: none"> • [2] <i>Coast inverse</i> was selected as a function for a digital input (<i>parameter group 5-1* Digital Inputs</i>). The corresponding terminal is not connected. • Coast activated by serial communication.
Ctrl. ramp-down	<p>[1] <i>Control Ramp-down</i> was selected in <i>parameter 14-10 Mains Failure</i>.</p> <ul style="list-style-type: none"> • The mains voltage is below the value set in <i>parameter 14-11 Mains Voltage at Mains Fault</i> at mains fault. • The frequency converter ramps down the motor using a controlled ramp down.
Current High	The frequency converter output current is above the limit set in <i>parameter 4-51 Warning Current High</i> .
Current Low	The frequency converter output current is below the limit set in <i>parameter 4-52 Warning Speed Low</i> .
DC Hold	[1] <i>DC hold</i> is selected in <i>parameter 1-80 Function at Stop</i> , and a stop command is active. The motor is held by a DC current set in <i>parameter 2-00 DC Hold/Preheat Current</i> .
DC Stop	<p>The motor is held with a DC current (<i>parameter 2-01 DC Brake Current</i>) for a specified time (<i>parameter 2-02 DC Braking Time</i>).</p> <ul style="list-style-type: none"> • The DC brake cut-in speed is reached in <i>parameter 2-03 DC Brake Cut In Speed [RPM]</i>, and a stop command is active. • [5] <i>DC-brake inverse</i> is selected as a function for a digital input (<i>parameter group 5-1* Digital Inputs</i>). The corresponding terminal is not active. • The DC brake is activated via serial communication.
Feedback high	The sum of all active feedbacks is above the feedback limit set in <i>parameter 4-57 Warning Feedback High</i> .
Feedback low	The sum of all active feedbacks is below the feedback limit set in <i>parameter 4-56 Warning Feedback Low</i> .

Freeze output	<p>The remote reference is active, which holds the present speed.</p> <ul style="list-style-type: none"> • [20] <i>Freeze output</i> is selected as a function for a digital input (<i>parameter group 5-1* Digital Inputs</i>). The corresponding terminal is active. Speed control is only possible via the terminal options [21] <i>Speed up</i> and [22] <i>Speed down</i>. • Hold ramp is activated via serial communication.
Freeze output request	A freeze output command was given, but the motor remains stopped until a run permissive signal is received.
Freeze ref.	<p>[19] <i>Freeze reference</i> is selected as a function for a digital input (<i>parameter group 5-1* Digital Inputs</i>). The corresponding terminal is active. The frequency converter saves the actual reference. Changing the reference is now only possible via terminal options [21] <i>Speed up</i> and [22] <i>Speed down</i>.</p>
Jog request	A jog command was given, but the motor remains stopped until a run permissive signal is received via a digital input.
Jogging	<p>The motor is running as programmed in <i>parameter 3-19 Jog Speed [RPM]</i>.</p> <ul style="list-style-type: none"> • [14] <i>Jog</i> was selected as a function for a digital input (<i>parameter group 5-1* Digital Inputs</i>). The corresponding terminal (for example, terminal 29) is active. • The jog function is activated via the serial communication. • The jog function is selected as a reaction for a monitoring function (for example, for the no signal function). The monitoring function is active.
Motor check	In <i>parameter 1-80 Function at Stop</i> , [2] <i>Motor Check</i> is selected. A stop command is active. To ensure that a motor is connected to the frequency converter, a permanent test current is applied to the motor.
OVC control	<p>Overvoltage control is activated via <i>parameter 2-17 Over-voltage Control</i>, [2] <i>Enabled</i>. The connected motor supplies the frequency converter with generative energy. The overvoltage control adjusts the V/Hz ratio to run the motor in controlled mode and to prevent the frequency converter from tripping.</p>
PowerUnit Off	<p>(Only frequency converters with a 24 V external supply installed).</p> <p>Mains supply to the frequency converter was removed, and the control card is supplied by the external 24 V.</p>

Protection md	Protection mode is active. The unit detected a critical status (overcurrent or overvoltage). <ul style="list-style-type: none"> To avoid tripping, the switching frequency is reduced to 4 kHz. If possible, protection mode ends after approximately 10 s. Protection mode can be restricted in <i>parameter 14-26 Trip Delay at Inverter Fault</i>.
Qstop	The motor is decelerating using <i>parameter 3-81 Quick Stop Ramp Time</i> . <ul style="list-style-type: none"> [4] <i>Quick stop inverse</i> is selected as a function for a digital input (<i>parameter group 5-1* Digital Inputs</i>). The corresponding terminal is not active. The quick stop function is activated via serial communication.
Ramping	The motor accelerates/decelerates using the active ramp up/down. The reference, a limit value, or a standstill is not yet reached.
Ref. high	The sum of all active references is above the reference limit set in <i>parameter 4-55 Warning Reference High</i> .
Ref. low	The sum of all active references is below the reference limit set in <i>parameter 4-54 Warning Reference Low</i> .
Run on ref.	The frequency converter runs in the reference range. The feedback value matches the setpoint value.
Run request	A start command was given, but the motor remains stopped until a run permissive signal is received via digital input.
Running	The frequency converter drives the motor.
Sleep Mode	The energy-saving function is enabled. The motor has stopped, but restarts automatically when required.
Speed high	Motor speed is above the value set in <i>parameter 4-53 Warning Speed High</i> .
Speed low	Motor speed is below the value set in <i>parameter 4-52 Warning Speed Low</i> .
Standby	In auto-on mode, the frequency converter starts the motor with a start signal from a digital input or serial communication.
Start delay	In <i>parameter 1-71 Start Delay</i> , a delay starting time was set. A start command is activated, and the motor starts after the start delay time expires.
Start fwd/rev	[12] <i>Enable start forward</i> and [13] <i>Enable start reverse</i> are selected as options for 2 different digital inputs (<i>parameter group 5-1* Digital Inputs</i>). The motor starts in forward or reverse direction depending on which terminal is activated.

Stop	The frequency converter received a stop command from the LCP, digital input, or serial communication.
Trip	An alarm occurred and the motor is stopped. Once the cause of the alarm is cleared, the frequency converter can be reset manually by pressing [Reset] or remotely by control terminals or serial communication.
Trip lock	An alarm occurred, and the motor is stopped. When the cause of the alarm is cleared, cycle power to the frequency converter. The frequency converter can then be reset manually by pressing [Reset], or remotely by control terminals or serial communication.

Table 7.3 Operation Status

NOTICE

In auto/remote mode, the frequency converter requires external commands to execute functions.

7.3 Warning and Alarm Types

Warnings

A warning is issued when an alarm condition is impending, or when an abnormal operating condition is present and may result in the frequency converter issuing an alarm. A warning clears by itself when the abnormal condition ceases.

Alarms

An alarm indicates a fault that requires immediate attention. The fault always triggers a trip or a trip lock. Reset the system after an alarm.

Trip

An alarm is issued when the frequency converter is tripped, meaning that the frequency converter suspends operation to prevent frequency converter or system damage. The motor coasts to a stop. The frequency converter logic continues to operate and monitor the frequency converter status. After the fault condition is remedied, the frequency converter can be reset. It is then ready to start operation again.

Resetting the frequency converter after trip/trip lock

A trip can be reset in any of 4 ways:

- Press [Reset] on the LCP.
- Digital reset input command.
- Serial communication reset input command.
- Auto reset.

Trip lock

Input power is cycled. The motor coasts to a stop. The frequency converter continues to monitor the frequency converter status. Remove input power to the frequency converter, correct the cause of the fault, and reset the frequency converter.

Warning and alarm displays

- A warning is shown in the LCP along with the warning number.
- An alarm flashes along with the alarm number.

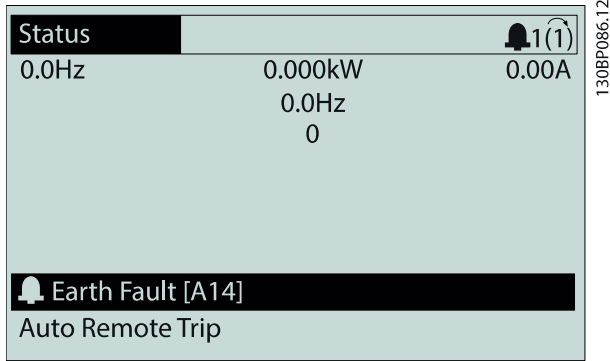
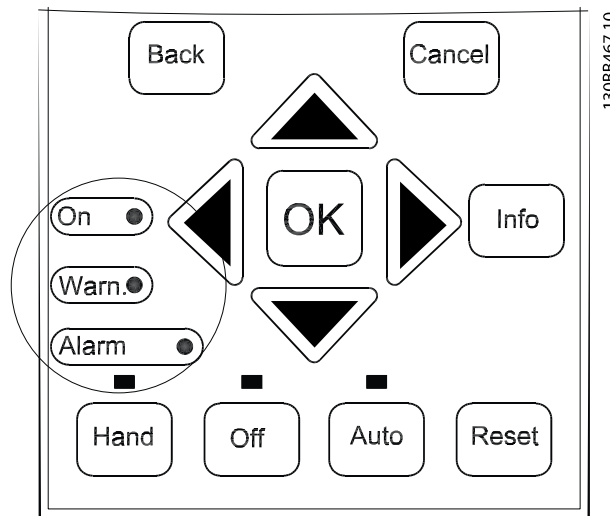

Illustration 7.2 Alarm Example

In addition to the text and alarm code in the LCP there are 3 status indicator lights.



	Warning indicator light	Alarm indicator light
Warning	On	Off
Alarm	Off	On (flashing)
Trip lock	On	On (flashing)

Illustration 7.3 Status Indicator Lights

7.4 List of Warnings and Alarms

The warning/alarm information in this chapter defines each warning/alarm condition, provides the probable cause for the condition, and details a remedy or troubleshooting procedure.

WARNING 1, 10 Volts low

The control card voltage from terminal 50 is <10 V. Remove some of the load from terminal 50, as the 10 V supply is overloaded. Maximum 15 mA or minimum 590 Ω.

A short circuit in a connected potentiometer or improper wiring of the potentiometer can cause this condition.

Troubleshooting

- Remove the wiring from terminal 50.
- If the warning clears, the problem is with the customer wiring.
- If the warning does not clear, replace the control card.

WARNING/ALARM 2, Live zero error

This warning or alarm only appears if programmed in parameter 6-01 Live Zero Timeout Function. The signal on 1 of the analog inputs is less than 50% of the minimum value programmed for that input. Broken wiring or signals from a faulty device cause this condition.

Troubleshooting

- Check connections on all the analog input terminals. Control card terminals 53 and 54 for signals, terminal 55 common. General Purpose I/O MCB 101 terminals 11 and 12 for signals, terminal 10 common. Analog I/O Option MCB 109 terminals 1, 3, 5 for signals, terminals 2, 4, 6 common).
- Check that the frequency converter programming and switch settings match the analog signal type.
- Perform an input terminal signal test.

WARNING/ALARM 3, No motor

No motor has been connected to the output of the drive.

WARNING/ALARM 4, Mains phase loss

A phase is missing on the supply side, or the mains voltage imbalance is too high. This message also appears in case of a fault in the input rectifier on the frequency converter. Options are programmed in parameter 14-12 Function at Mains Imbalance.

Troubleshooting

- Check the supply voltage and supply currents to the frequency converter.

WARNING 5, DC link voltage high

The DC-link voltage is higher than the high-voltage warning limit. The limit depends on the frequency converter voltage rating. The unit is still active.

WARNING 6, DC link voltage low

The DC-link voltage is lower than the low-voltage warning limit. The limit depends on the frequency converter voltage rating. The unit is still active.

WARNING/ALARM 7, DC overvoltage

If the DC-link voltage exceeds the limit, the frequency converter trips after some time.

Troubleshooting

- Connect a brake resistor.
- Extend the ramp time.
- Change the ramp type.
- Activate the functions in *parameter 2-10 Brake Function*.
- Increase *parameter 14-26 Trip Delay at Inverter Fault*.

WARNING/ALARM 8, DC under voltage

If the DC-link voltage drops below the undervoltage limit, the frequency converter checks if a 24 V DC back-up supply is connected. If no 24 V DC back-up supply is connected, the frequency converter trips after a fixed time delay. The time delay varies with unit size.

Troubleshooting

- Check that the supply voltage matches the frequency converter voltage.
- Perform an input voltage test.
- Perform a soft charge circuit test.

WARNING/ALARM 9, Inverter overload

The frequency converter is about to cut out because of an overload (too high current for too long). The counter for electronic thermal inverter protection issues a warning at 98% and trips at 100%, while issuing an alarm. The frequency converter *cannot* be reset until the counter is below 90%.

Troubleshooting

- Compare the output current shown on the LCP with the frequency converter rated current.
- Compare the output current shown on the LCP with measured motor current.
- Show the thermal load on the LCP and monitor the value. When running above the frequency converter continuous current rating, the counter should increase. When running below the frequency converter continuous current rating, the counter should decrease.

WARNING/ALARM 10, Motor overload temperature

According to the electronic thermal protection (ETR), the motor is too hot. Select whether the frequency converter issues a warning or an alarm when the counter reaches 100% in *parameter 1-90 Motor Thermal Protection*. The fault occurs when the motor overload exceeds 100% for too long.

Troubleshooting

- Check for motor overheating.
- Check if the motor is mechanically overloaded.
- Check that the motor current set in *parameter 1-24 Motor Current* is correct.
- Ensure the motor data in parameters *1-20* through *1-25* is set correctly.

- If an external fan is used, check that it is selected in *parameter 1-91 Motor External Fan*.
- Running AMA in *parameter 1-29 Automatic Motor Adaptation (AMA)* tunes the frequency converter to the motor more accurately and reduces thermal loading.

WARNING/ALARM 11, Motor thermistor overtemp

The thermistor may be disconnected. Select whether the frequency converter issues a warning or an alarm in *parameter 1-90 Motor Thermal Protection*.

Troubleshooting

- Check for motor overheating.
- Check if the motor is mechanically overloaded.
- Check that the thermistor is connected correctly between either terminal 53 or 54 (analog voltage input) and terminal 50 (+10 V supply) and that the terminal switch for 53 or 54 is set for voltage. Check *parameter 1-93 Thermistor Source* selects terminal 53 or 54.
- When using digital inputs 18 or 19, check that the thermistor is connected correctly between either terminal 18 or 19 (digital input PNP only) and terminal 50.
- If a KTY sensor is used, check for correct connection between terminals 54 and 55.
- If using a thermal switch or thermistor, check that the programming if *parameter 1-93 Thermistor Source* matches sensor wiring.

WARNING/ALARM 12, Torque limit

The torque has exceeded the value in *parameter 4-16 Torque Limit Motor Mode* or the value in *parameter 4-17 Torque Limit Generator Mode*. *Parameter 14-25 Trip Delay at Torque Limit* can change this from a warning-only condition to a warning followed by an alarm.

Troubleshooting

- If the motor torque limit is exceeded during ramp-up, extend the ramp-up time.
- If the generator torque limit is exceeded during ramp down, extend the ramp-down time.
- If torque limit occurs while running, possibly increase the torque limit. Be sure that the system can operate safely at a higher torque.
- Check the application for excessive current draw on the motor.

WARNING/ALARM 13, Over current

The inverter peak current limit (approximately 200% of the rated current) is exceeded. The warning lasts about 1.5 s, then the frequency converter trips and issues an alarm. Shock loading or fast acceleration with high-inertia loads can cause this fault. If extended mechanical brake control is selected, the trip can be reset externally.

Troubleshooting

- Remove power and check if the motor shaft can be turned.
- Check that the motor size matches the frequency converter.
- Check *parameters 1-20 to 1-25* for correct motor data.

ALARM 14, Earth (ground) fault

There is current from the output phases to ground, either in the cable between the frequency converter and the motor, or in the motor itself.

Troubleshooting

- Remove power from the frequency converter and repair the ground fault.
- Check for ground faults in the motor by measuring the resistance to ground of the motor cables and the motor with a megohmmeter.
- Perform current sensor test.

ALARM 15, Hardware mismatch

A fitted option is not operational with the present control board hardware or software.

Record the value of the following parameters and contact the local Wilo supplier:

- *Parameter 15-40 FC Type.*
- *Parameter 15-41 Power Section.*
- *Parameter 15-42 Voltage.*
- *Parameter 15-43 Software Version.*
- *Parameter 15-45 Actual Typecode String.*
- *Parameter 15-49 SW ID Control Card.*
- *Parameter 15-50 SW ID Power Card.*
- *Parameter 15-60 Option Mounted.*
- *Parameter 15-61 Option SW Version* (for each option slot).

ALARM 16, Short circuit

There is short-circuiting in the motor or motor wiring.

Troubleshooting

- Remove power from the frequency converter and repair the short circuit.

WARNING/ALARM 17, Control word timeout

There is no communication to the frequency converter.

The warning is only active when *parameter 8-04 Control Timeout Function* is NOT set to [0] Off.

If *parameter 8-04 Control Timeout Function* is set to [5] Stop and trip, a warning appears and the frequency converter ramps down until it trips, then it shows an alarm.

Troubleshooting

- Check the connections on the serial communication cable.
- Increase *parameter 8-03 Control Timeout Time*.

- Check the operation of the communication equipment.
- Verify a proper installation based on EMC requirements.

WARNING/ALARM 22, Hoist mechanical brake

When this warning is active, the LCP shows the type of issue.

0 = The torque ref. was not reached before timeout.

1 = There was no brake feedback before timeout.

WARNING 23, Internal fan fault

The fan warning function is an extra protective function that checks if the fan is running/mounted. The fan warning can be disabled in *parameter 14-53 Fan Monitor* ([0] Disabled).

Troubleshooting

- Check the fan resistance.
- Check the soft charge fuses.

WARNING 24, External fan fault

The fan warning function is an extra protective function that checks if the fan is running/mounted. The fan warning can be disabled in *parameter 14-53 Fan Monitor* ([0] Disabled).

Troubleshooting

- Check the fan resistance.
- Check the soft charge fuses.

WARNING 25, Brake resistor short circuit

The brake resistor is monitored during operation. If a short circuit occurs, the brake function is disabled and the warning appears. The frequency converter is still operational but without the brake function. Remove power from the frequency converter and replace the brake resistor (see *parameter 2-15 Brake Check*).

WARNING/ALARM 26, Brake resistor power limit

The power transmitted to the brake resistor is calculated as a mean value over the last 120 s of run time. The calculation is based on the DC-link voltage and the brake resistance value set in *parameter 2-16 AC brake Max. Current*. The warning is active when the dissipated braking is higher than 90% of the brake resistance power. If [2] Trip is selected in *parameter 2-13 Brake Power Monitoring*, the frequency converter trips when the dissipated braking power reaches 100%.

WARNING/ALARM 27, Brake chopper fault

The brake transistor is monitored during operation. If a short circuit occurs, the brake function is disabled and a warning is issued. The frequency converter is still operational, but since the brake transistor has short-circuited, substantial power is transmitted to the brake resistor, even if it is inactive.

Remove power from the frequency converter and remove the brake resistor.

This alarm/warning could also occur if the brake resistor overheats. Terminals 104 and 106 are available as brake

resistor Klixon inputs, see *Brake Resistor Temperature Switch* in the *design guide*.

WARNING/ALARM 28, Brake check failed

The brake resistor is not connected or not working. Check *parameter 2-15 Brake Check*.

ALARM 29, Heat sink temp

The maximum temperature of the heat sink has been exceeded. The temperature fault does not reset until the temperature drops below a defined heatsink temperature. The trip and reset points vary based on the frequency converter power size.

Troubleshooting

Check for the following conditions:

- Ambient temperature too high.
- Motor cable too long.
- Incorrect airflow clearance above and below the frequency converter.
- Blocked airflow around the frequency converter.
- Damaged heat sink fan.
- Dirty heat sink.

This alarm is based on the temperature measured by the heat sink sensor mounted inside the IGBT modules.

Troubleshooting

- Check the fan resistance.
- Check the soft charge fuses.
- Check the IGBT thermal sensor.

ALARM 30, Motor phase U missing

Motor phase U between the frequency converter and the motor is missing.

Troubleshooting

- Remove power from the frequency converter and check motor phase U.

ALARM 31, Motor phase V missing

Motor phase V between the frequency converter and the motor is missing.

Troubleshooting

- Remove power from the frequency converter and check motor phase V.

ALARM 32, Motor phase W missing

Motor phase W between the frequency converter and the motor is missing.

Troubleshooting

- Remove power from the frequency converter and check motor phase W.

ALARM 33, Inrush fault

Too many power-ups have occurred within a short time period. Let the unit cool to operating temperature.

WARNING/ALARM 34, Fieldbus communication fault

The fieldbus on the communication option card is not working.

WARNING/ALARM 36, Mains failure

This warning/alarm is only active if the supply voltage to the frequency converter is lost and *parameter 14-10 Mains Failure* is NOT set to [0] No Function.

Troubleshooting

- Check the fuses to the frequency converter and mains power supply to the unit.

ALARM 38, Internal fault

When an internal fault occurs, a code number defined in *Table 7.4* is shown.

Troubleshooting

- Cycle power.
- Check that the option is properly installed.
- Check for loose or missing wiring.

Contact the Wilo supplier or Wilo service if necessary. Note the code number for further troubleshooting directions.

Number	Text
0	The serial port cannot be initialized. Contact the Wilo supplier or Wilo Service.
256–258	Power EEPROM data is defective or too old.
512	The control board EEPROM data is defective or too old.
513	Communication timeout reading EEPROM data.
514	Communication timeout reading EEPROM data.
515	Application-oriented control cannot recognize the EEPROM data.
516	Cannot write to the EEPROM because a write command is in progress.
517	Write command is under timeout.
518	Failure in the EEPROM.
519	Missing or invalid barcode data in EEPROM.
783	Parameter value outside of minimum/maximum limits.
1024–1279	Sending a CAN telegram failed.
1281	Digital signal processor flash timeout.
1282	Power micro software version mismatch.
1283	Power EEPROM data version mismatch.
1284	Cannot read digital signal processor software version.
1299	The option SW in slot A is too old.
1300	The option SW in slot B is too old.
1301	The option SW in slot C0 is too old.
1302	The option SW in slot C1 is too old.
1315	The option SW in slot A is not supported (not allowed).
1316	The option SW in slot B is not supported (not allowed).
1317	The option SW in slot C0 is not supported (not allowed).
1318	The option SW in slot C1 is not supported (not allowed).

Number	Text
1379	The option A did not respond when calculating the platform version.
1380	The option B did not respond when calculating the platform version.
1381	The option C0 did not respond when calculating the platform version.
1382	The option C1 did not respond when calculating the platform version.
1536	An exception in the application-oriented control is registered. Debug information written in LCP.
1792	The DSP watchdog is active. Debugging of power part data, motor-oriented control data not transferred correctly.
2049	Power data restarted.
2064–2072	H081x: Option in slot x restarted.
2080–2088	H082x: Option in slot x issued a power-up wait.
2096–2104	H983x: Option in slot x issued a legal power-up wait.
2304	Could not read any data from power EEPROM.
2305	Missing SW version from power unit.
2314	Missing power unit data from power unit.
2315	Missing SW version from power unit.
2316	Missing lo_stepage from power unit.
2324	The power card configuration is determined to be incorrect at power-up.
2325	A power card has stopped communicating while main power is applied.
2326	The power card configuration is determined to be incorrect after the delay for power cards to register.
2327	Too many power card locations are registered as present.
2330	Power size information between the power cards does not match.
2561	No communication from DSP to ATACD.
2562	No communication from ATACD to DSP (state running).
2816	Stack overflow control board module.
2817	Scheduler slow tasks.
2818	Fast tasks.
2819	Parameter thread.
2820	LCP stack overflow.
2821	Serial port overflow.
2822	USB port overflow.
2836	cflistMempool too small.
3072–5122	Parameter value is outside its limits.
5123	Option in slot A: Hardware incompatible with control board hardware.
5124	Option in slot B: Hardware incompatible with control board hardware.
5125	Option in slot C0: Hardware incompatible with control board hardware.
5126	Option in slot C1: Hardware incompatible with control board hardware.

Number	Text
5376–6231	Out of memory.

Table 7.4 Code Numbers for Internal Faults

ALARM 39, Heat sink sensor

No feedback from the heat sink temperature sensor.

The signal from the IGBT thermal sensor is not available on the power card. The problem could be in the power card, in the gatedrive card, or the ribbon cable between the power card and the gatedrive card.

WARNING 40, Overload of digital output terminal 27

Check the load connected to terminal 27 or remove the short circuit connection. Check *parameter 5-00 Digital I/O Mode* and *parameter 5-01 Terminal 27 Mode*.

WARNING 41, Overload of digital output terminal 29

Check the load connected to terminal 29 or remove the short circuit connection. Check *parameter 5-00 Digital I/O Mode* and *parameter 5-02 Terminal 29 Mode*.

WARNING 42, Overload of digital output on X30/6 or overload of digital output on X30/7

For X30/6, check the load connected to X30/6 or remove the short circuit connection. Check *parameter 5-32 Term X30/6 Digi Out (MCB 101)*.

For X30/7, check the load connected to X30/7 or remove the short circuit connection. Check *parameter 5-33 Term X30/7 Digi Out (MCB 101)*.

ALARM 46, Power card supply

The supply on the power card is out of range.

There are 3 supplies powered by the switch mode power supply (SMPS) on the power card: 24 V, 5 V, ±18 V. When powered with 24 V DC with the 24 V DC Supply MCB 107 option, only the 24 V and 5 V supplies are monitored. When powered with 3-phase mains voltage, all 3 supplies are monitored.

WARNING 47, 24 V supply low

The 24 V DC supply is measured on the control card. The external 24 V DC back-up supply may be overloaded, otherwise contact the Wilo supplier.

WARNING 48, 1.8 V supply low

The 1.8 V DC supply used on the control card is outside of the allowable limits. The supply is measured on the control card. Check for a defective control card. If an option card is present, check for an overvoltage condition.

WARNING 49, Speed limit

When the speed is not within the specified range in *parameter 4-11 Motor Speed Low Limit [RPM]* and *parameter 4-13 Motor Speed High Limit [RPM]*, the frequency converter shows a warning. When the speed is below the specified limit in *parameter 1-86 Trip Speed Low [RPM]* (except when starting or stopping) the frequency converter trips.

ALARM 50, AMA calibration failed

Contact the Wilo supplier or Wilo Service.

ALARM 51, AMA check U_{nom} and I_{nom}

The settings for motor voltage, motor current, and motor power are wrong. Check the settings in *parameters 1-20* to *1-25*.

ALARM 52, AMA low I_{nom}

The motor current is too low. Check the settings.

ALARM 53, AMA motor too big

The motor is too big for the AMA to operate.

ALARM 54, AMA motor too small

The motor is too small for the AMA to operate.

ALARM 55, AMA parameter out of range

The parameter values of the motor are outside of the acceptable range. AMA does not run.

ALARM 56, AMA interrupted by user

The user has interrupted the AMA.

ALARM 57, AMA internal fault

Try to restart AMA several times, until the AMA is carried out. Repeated runs may heat the motor to a level where the resistance R_s and R_r are increased. Usually this is not critical.

ALARM 58, AMA Internal fault

Contact the Wilo supplier.

WARNING 59, Current limit

The current is higher than the value in *parameter 4-18 Current Limit*. Ensure that motor data in *parameters 1-20* to *1-25* are set correctly. Possibly increase the current limit. Be sure that the system can operate safely at a higher limit.

WARNING 60, External interlock

External interlock has been activated. To resume normal operation:

1. Apply 24 V DC to the terminal programmed for external interlock.
2. Reset the frequency converter via
 - 2a Serial communication.
 - 2b Digital I/O.
 - 2c The [Reset] key.

WARNING 62, Output frequency at maximum limit

The output frequency is higher than the value set in *parameter 4-19 Max Output Frequency*.

WARNING 64, Voltage Limit

The load and speed combination demands a motor voltage higher than the actual DC-link voltage.

WARNING/ALARM 65, Control card over temperature

The control card has reached its trip temperature of 75 °C (167 °F).

WARNING 66, Heat sink temperature low

The frequency converter is too cold to operate. This warning is based on the temperature sensor in the IGBT module. Also, a trickle amount of current can be supplied to the frequency converter whenever the motor is stopped

by setting *parameter 2-00 DC Hold/Preheat Current* at 5% and *parameter 1-80 Function at Stop*.

Troubleshooting

- Check the temperature sensor.
- Check the sensor wire between the IGBT and the gatedrive card.

ALARM 67, Option module configuration has changed

One or more options have either been added or removed since the last power-down. Check that the configuration change is intentional and reset the unit.

ALARM 68, Safe Stop activated

STO is activated.

Troubleshooting

- To resume normal operation, apply 24 V DC to terminal 37, then send a reset signal (via bus, digital I/O, or by pressing [Reset]).

ALARM 69, Power card temperature

The temperature sensor on the power card is either too hot or too cold.

Troubleshooting

- Check the operation of the door fans.
- Check that the filters for the door fans are not blocked.
- Check that the gland plate is properly installed on IP21/IP54 (NEMA 1/12) frequency converters.

ALARM 70, Illegal FC configuration

The control card and power card are incompatible.

Troubleshooting

- Contact the supplier with the type code of the unit from the nameplate and the part numbers of the cards to check compatibility.

ALARM 71, PTC 1 safe stop

Safe Torque Off is activated from the PTC Thermistor Card MCB 112 (motor too warm). Normal operation can be resumed when the MCB 112 applies 24 V DC to T37 again (when the motor temperature reaches an acceptable level) and when the digital input from the MCB 112 is deactivated. When that happens, a reset signal must be sent (via bus, digital I/O, or by pressing [Reset]).

NOTICE

If automatic restart is enabled, the motor may start when the fault is cleared.

ALARM 72, Dangerous failure

Safe Torque Off (STO) with trip lock. Unexpected signal levels on safe torque off and digital input from the VLT® PTC Thermistor Card MCB 112.

WARNING 73, Safe Stop auto restart

Safe Torque Off (STO). With automatic restart enabled, the motor can start when the fault is cleared.

WARNING 76, Power unit setup

The required number of power units does not match the detected number of active power units. When replacing an enclosure size F module, this warning occurs if the power-specific data in the module power card does not match the rest of the frequency converter. If the power card connection is lost, the unit also triggers this warning.

Troubleshooting

- Confirm that the spare part and its power card are the correct part number.
- Ensure that the 44-pin cables between the MDCIC and power cards are mounted properly.

WARNING 77, Reduced power mode

This warning indicates that the frequency converter is operating in reduced power mode (that is, less than the allowed number of inverter sections). This warning is generated on power cycle when the frequency converter is set to run with fewer inverters and remains on.

ALARM 79, Illegal power section configuration

The scaling card is the incorrect part number or not installed. Also, the MK102 connector on the power card could not be installed.

ALARM 80, Drive initialised to default value

Parameter settings are initialized to default settings after a manual reset.

Troubleshooting

- Reset the unit to clear the alarm.

ALARM 81, CSIV corrupt

CSIV (Customer-specific initialization values) file has syntax errors.

ALARM 82, CSIV parameter error

CSIV (Customer-specific initialization values) failed to initialize a parameter.

ALARM 85, Dang fail PB

PROFIBUS/PROFIsafe error.

ALARM 92, No flow

A no-flow condition is detected in the system.

Parameter 22-23 No-Flow Function is set for alarm.

Troubleshooting

- Troubleshoot the system and reset the frequency converter after clearing the fault.

ALARM 93, Dry pump

A no-flow condition in the system with the frequency converter operating at high speed can indicate a dry pump. *Parameter 22-26 Dry Pump Function* is set for alarm.

Troubleshooting

- Troubleshoot the system and reset the frequency converter after clearing the fault.

ALARM 94, End of curve

The feedback is lower than the setpoint. This condition can indicate leakage in the system. *Parameter 22-50 End of Curve Function* is set for alarm.

Troubleshooting

- Troubleshoot the system and reset the frequency converter after clearing the fault.

ALARM 95, Broken belt

Torque is below the torque level set for no load, indicating a broken belt. *Parameter 22-60 Broken Belt Function* is set for alarm.

Troubleshooting

- Troubleshoot the system and reset the frequency converter after clearing the fault.

ALARM 100, Derag limit fault

The *Deragging* feature failed during execution. Check the pump impeller for blockage.

WARNING/ALARM 104, Mixing fan fault

The fan monitor checks that the fan is spinning at frequency converter power-up or whenever the mixing fan is turned on. If the fan is not operating, the fault is issued. The mixing-fan fault can be configured as a warning or an alarm trip by *parameter 14-53 Fan Monitor*.

Troubleshooting

- Cycle power to the frequency converter to determine if the warning/alarm returns.

WARNING 250, New spare part

A component in the frequency converter has been replaced. To resume normal operation, reset the frequency converter.

WARNING 251, New typecode

The power card or other components have been replaced and the type code changed.

Troubleshooting

- Reset to remove the warning and resume normal operation.

7.5 Troubleshooting

Symptom	Possible cause	Test	Solution
Display dark/No function	Missing input power.	See <i>Table 4.3</i> .	Check the input power source.
	Missing or open fuses, or circuit breaker tripped.	See <i>Open fuses and tripped circuit breaker</i> in this table for possible causes.	Follow the recommendations provided.
	No power to the LCP.	Check the LCP cable for proper connection or damage.	Replace the faulty LCP or connection cable.
	Shortcut on control voltage (terminal 12 or 50) or at control terminals.	Check the 24 V control voltage supply for terminals 12/13 to 20-39 or 10 V supply for terminals 50-55.	Wire the terminals properly.
	Incompatible LCP.	–	Use only LCP 101 (P/N 130B1124) or LCP 102 (P/N 130B1107).
	Wrong contrast setting.	–	Press [Status] + [▲]/[▼] to adjust the contrast.
	Display (LCP) is defective.	Test using a different LCP.	Replace the faulty LCP or connection cable.
	Internal voltage supply fault or SMPS is defective.	–	Contact supplier.
Intermittent display	Overloaded supply (SMPS) due to improper control wiring or a fault within the frequency converter.	To rule out a problem in the control wiring, disconnect all control wiring by removing the terminal blocks.	If the display stays lit, the problem is in the control wiring. Check the wiring for short circuits or incorrect connections. If the display continues to cut out, follow the procedure for display dark.
Motor not running	Service switch is open or missing motor connection.	Check if the motor is connected and the connection is not interrupted (by a service switch or other device).	Connect the motor and check the service switch.
	No mains power with 24 V DC option card.	If the display is functioning but no output, check that mains power is applied to the frequency converter.	Apply mains power to run the unit.
	LCP stop.	Check if [Off] has been pressed.	Press [Auto On] or [Hand On] (depending on operating mode) to run the motor.
	Missing start signal (Standby).	Check <i>parameter 5-10 Terminal 18 Digital Input</i> for correct setting for terminal 18 (use default setting).	Apply a valid start signal to start the motor.
	Motor coast signal active (Coasting).	Check <i>parameter 5-12 Terminal 27 Digital Input</i> for correct setting for terminal 27 (use default setting).	Apply 24 V on terminal 27 or program this terminal to <i>No operation</i> .
	Wrong reference signal source.	Check the following: <ul style="list-style-type: none"> Reference signal: Local, remote, or bus reference. Preset reference. Terminal connection. Scaling of terminals. Reference signal availability. 	Program the correct settings. Check <i>parameter 3-13 Reference Site</i> . Set preset reference active in <i>parameter group 3-1* References</i> .
Motor running in wrong direction	Motor rotation limit.	Check that <i>parameter 4-10 Motor Speed Direction</i> is programmed correctly.	Program the correct settings.
	Active reversing signal.	Check if a reversing command is programmed for the terminal in <i>parameter group 5-1* Digital inputs</i> .	Deactivate reversing signal.
	Wrong motor phase connection.	–	See <i>chapter 5.5 Checking Motor Rotation</i> .

Symptom	Possible cause	Test	Solution
Motor is not reaching maximum speed	Frequency limits are set incorrectly.	Check the output limits in <i>parameter 4-13 Motor Speed High Limit [RPM]</i> , <i>parameter 4-14 Motor Speed High Limit [Hz]</i> and <i>parameter 4-19 Max Output Frequency</i> .	Program the correct limits.
	Reference input signal is not scaled correctly.	Check the reference input signal scaling in <i>parameter group 6-0* Analog I/O Mode</i> and <i>parameter group 3-1* References</i> . Check the reference limits in <i>parameter group 3-0* Reference Limit</i> .	Program the correct settings.
Motor speed unstable	Possible incorrect parameter settings.	Check the settings of all motor parameters, including all motor compensation settings. For closed-loop operation, check the PID settings.	Check the settings in <i>parameter group 1-6* Load Depen. Setting</i> . For closed-loop operation, check the settings in <i>parameter group 20-0* Feedback</i> .
Motor runs rough	Possible overmagnetization.	Check for incorrect motor settings in all motor parameters.	Check the motor settings in <i>parameter groups 1-2* Motor Data</i> , <i>1-3* Adv Motor Data</i> , and <i>1-5* Load Indep. Setting</i> .
Motor does not brake	Possible incorrect settings in the brake parameters. Possible too short ramp-down times.	Check the brake parameters. Check the ramp time settings.	Check <i>parameter groups 2-0* DC Brake</i> and <i>3-0* Reference Limits</i> .
Open power fuses or circuit breaker trip	Phase-to-phase short circuit.	The motor or panel has a short phase-to-phase. Check the motor and panel phase for short circuits.	Eliminate any short circuits detected.
	Motor overload.	Motor is overloaded for the application.	Perform a start-up test and verify that the motor current is within the specifications. If the motor current exceeds the nameplate full load current, the motor may run only with reduced load. Review the specifications for the application.
	Loose connections.	Perform a pre-startup check for loose connections.	Tighten any loose connections.
Mains current imbalance >3%	Problem with the mains power (See <i>alarm 4, Mains phase loss</i> description).	Rotate input power leads into the frequency converter 1 position: A to B, B to C, C to A.	If imbalanced leg follows the wire, it is a power problem. Check the mains supply.
	Problem with the frequency converter.	Rotate input power leads into the frequency converter 1 position: A to B, B to C, C to A.	If imbalance leg stays on the same input terminal, it is a problem with the unit. Contact the supplier.
Motor current imbalance >3%	Problem with the motor or motor wiring.	Rotate output motor cables 1 position: U to V, V to W, W to U.	If imbalanced leg follows the wire, the problem is in the motor or motor wiring. Check the motor and motor wiring.
	Problem with the frequency converter.	Rotate output motor cables 1 position: U to V, V to W, W to U.	If imbalance leg stays on same output terminal, it is a problem with the frequency converter. Contact the Wilo supplier.
Frequency converter acceleration problems	Motor data was entered incorrectly.	If warnings or alarms occur, see <i>chapter 7.4 List of Warnings and Alarms</i> . Check that motor data is entered correctly.	Increase the ramp-up time in <i>parameter 3-41 Ramp 1 Ramp Up Time</i> . Increase the current limit in <i>parameter 4-18 Current Limit</i> . Increase the torque limit in <i>parameter 4-16 Torque Limit Motor Mode</i> .
Frequency converter deceleration problems	Motor data was entered incorrectly.	If warnings or alarms occur, see <i>chapter 7.4 List of Warnings and Alarms</i> . Check that motor data is entered correctly.	Increase the ramp-down time in <i>parameter 3-42 Ramp 1 Ramp Down Time</i> . Enable overvoltage control in <i>parameter 2-17 Over-voltage Control</i> .

Symptom	Possible cause	Test	Solution
Acoustic noise or vibration	Resonances.	Bypass critical frequencies by using parameters in <i>parameter group 4-6* Speed Bypass</i> .	Check if noise and/or vibration have been reduced to an acceptable limit.
		Turn off overmodulation in <i>parameter 14-03 Overmodulation</i> .	
		Change the switching pattern and frequency in <i>parameter group 14-0* Inverter Switching</i> .	
		Increase resonance dampening in <i>parameter 1-64 Resonance Damping</i> .	

Table 7.5 Troubleshooting

8 Specifications

8.1 Electrical Data

8.1.1 Mains Supply 1x200–240 V AC

Type designation	P1K1	P1K5	P2K2	P3K0	P3K7	P5K5	P7K5	P15K	P22K
Typical shaft output [kW]	1.1	1.5	2.2	3.0	3.7	5.5	7.5	15	22
Typical shaft output at 240 V [hp]	1.5	2.0	2.9	4.0	4.9	7.5	10	20	30
Protection rating IP20/Chassis	A3	–	–	–	–	–	–	–	–
Protection rating IP21/Type 1	–	B1	B1	B1	B1	B1	B2	C1	C2
Protection rating IP55/Type 12	A5	B1	B1	B1	B1	B1	B2	C1	C2
Protection rating IP66/NEMA 4X	A5	B1	B1	B1	B1	B1	B2	C1	C2
Output current									
Continuous (3x200–240 V) [A]	6.6	7.5	10.6	12.5	16.7	24.2	30.8	59.4	88
Intermittent (3x200–240 V) [A]	7.3	8.3	11.7	13.8	18.4	26.6	33.4	65.3	96.8
Continuous kVA at 208 V [kVA]	2.4	2.7	3.8	4.5	6.0	8.7	11.1	21.4	31.7
Maximum input current									
Continuous (1x200–240 V) [A]	12.5	15	20.5	24	32	46	59	111	172
Intermittent (1x200–240 V) [A]	13.8	16.5	22.6	26.4	35.2	50.6	64.9	122.1	189.2
Maximum pre-fuses [A]	20	30	40	40	60	80	100	150	200
Additional specifications									
Maximum cable cross-section (mains, motor, brake) [mm ² (AWG)]	0.2–4 (4–10)					10 (7)	35 (2)	50 (1/0)	95 (4/0)
Maximum cable cross-section for mains with disconnect switch [mm ² (AWG)]	5.26 (10)	16 (6)	16 (6)	16 (6)	16 (6)	16 (6)	25 (3)	50 (1/0)	2 x 50 (2 x 1/0) ^{9) 10)}
Maximum cable cross-section for mains without disconnect switch [mm ² (AWG)]	5.26 (10)	16 (6)	16 (6)	16 (6)	16 (6)	16 (6)	25 (3)	50 (1/0)	95 (4/0)
Cable insulation temperature rating [°C (°F)]	75 (167)	75 (167)	75 (167)	75 (167)	75 (167)	75 (167)	75 (167)	75 (167)	75 (167)
Estimated power loss ³⁾ at rated maximum load [W] ⁴⁾	44	30	44	60	74	110	150	300	440
Efficiency ⁵⁾	0.98	0.98	0.98	0.98	0.98	0.98	0.98	0.98	0.98

Table 8.1 Mains Supply 1x200–240 V AC, Normal Overload 110% for 1 Minute, P1K1–P22K

8.1.2 Mains Supply 3x200–240 V AC

Type designation	PK25		PK37		PK55		PK75	
	HO	NO	HO	NO	HO	NO	HO	NO
High/normal overload ¹⁾								
Typical shaft output [kW]	0.25		0.37		0.55		0.75	
Typical shaft output at 208 V [hp]	0.34		0.5		0.75		1	
Protection rating IP20/Chassis ⁶⁾	A2		A2		A2		A2	
Protection rating IP21/Type 1								
Protection rating IP55/Type 12	A4/A5		A4/A5		A4/A5		A4/A5	
Protection rating IP66/NEMA 4X								
Output current								
Continuous (3x200–240 V) [A]	1.8		2.4		3.5		4.6	
Intermittent (3x200–240 V) [A]	2.7	2.0	3.6	2.6	5.3	3.9	6.9	5.1
Continuous kVA at 208 V [kVA]	0.65		0.86		1.26		1.66	
Maximum input current								
Continuous (3x200–240 V) [A]	1.6		2.2		3.2		4.1	
Intermittent (3x200–240 V) [A]	2.4	1.8	3.3	2.4	4.8	3.5	6.2	4.5
Maximum pre-fuses [A]	10		10		10		10	
Additional specifications								
Maximum cable cross-section ²⁾ for mains, motor, brake, and load sharing [mm ² (AWG)]	4, 4, 4 (12, 12, 12) (minimum 0.2 (24))							
Maximum cable cross-section ²⁾ for mains disconnect [mm ² (AWG)]	6, 4, 4 (10, 12, 12)							
Estimated power loss ³⁾ at rated maximum load [W (hp)] ⁴⁾	21 (0.03)		29 (0.04)		42 (0.06)		54 (0.07)	
Efficiency ⁵⁾	0.94		0.94		0.95		0.95	

8

Table 8.2 Mains Supply 3x200–240 V AC, PK25–PK75

Type designation	P1K1		P1K5		P2K2		P3K0		P3K7	
	HO	NO	HO	NO	HO	NO	HO	NO	HO	NO
High/normal overload ¹⁾										
Typical shaft output [kW]	1.1		1.5		2.2		3.0		3.7	
Typical shaft output at 208 V [hp]	1.5		2		3		4		5	
Protection rating IP20/Chassis ⁶⁾	A2		A2		A2		A3		A3	
Protection rating IP21/Type 1										
Protection rating IP55/Type 12	A4/A5		A4/A5		A4/A5		A5		A5	
Protection rating IP66/NEMA 4X										
Output current										
Continuous (3x200–240 V) [A]	6.6		7.5		10.6		12.5		16.7	
Intermittent (3x200–240 V) [A]	9.9	7.3	11.3	8.3	15.9	11.7	18.8	13.8	25	18.4
Continuous kVA at 208 V [kVA]	2.38		2.70		3.82		4.50		6.00	
Maximum input current										
Continuous (3x200–240 V) [A]	5.9		6.8		9.5		11.3		15.0	
Intermittent (3x200–240 V) [A]	8.9	6.5	10.2	7.5	14.3	10.5	17.0	12.4	22.5	16.5
Maximum pre-fuses [A]	20		20		20		32		32	
Additional specifications										
Maximum cable cross-section ²⁾ for mains, motor, brake, and load sharing [mm ² (AWG)]	4, 4, 4 (12, 12, 12) (minimum 0.2 (24))									
Maximum cable cross-section ²⁾ for mains disconnect [mm ²] [(AWG)]	6, 4, 4 (10, 12, 12)									
Estimated power loss ³⁾ at rated maximum load [W (hp)] ⁴⁾	63 (0.09)		82 (0.11)		116 (0.16)		155 (0.21)		185 (0.25)	
Efficiency ⁵⁾	0.96		0.96		0.96		0.96		0.96	

Table 8.3 Mains Supply 3x200–240 V AC, P1K1–P3K7

Type designation	P5K5		P7K5		P11K		P15K	
High/normal overload ¹⁾	HO	NO	HO	NO	HO	NO	HO	NO
Typical shaft output [kW]	3.7	5.5	5.5	7.5	7.5	11	11	15
Typical shaft output at 208 V [hp]	5.0	7.5	7.5	10	10	15	15	20
IP20/Chassis ⁷⁾	B3		B3		B3		B4	
Protection rating IP21/Type 1	B1		B1		B1		B2	
Protection rating IP55/Type 12								
Protection rating IP66/NEMA 4X								
Output current								
Continuous (3x200–240 V) [A]	16.7	24.2	24.2	30.8	30.8	46.2	46.2	59.4
Intermittent (3x200–240 V) [A]	26.7	26.6	38.7	33.9	49.3	50.8	73.9	65.3
Continuous kVA at 208 V [kVA]	6.0	8.7	8.7	11.1	11.1	16.6	16.6	21.4
Maximum input current								
Continuous (3x200–240 V) [A]	15.0	22.0	22.0	28.0	28.0	42.0	42.0	54.0
Intermittent (3x200–240 V) [A]	24.0	24.2	35.2	30.8	44.8	46.2	67.2	59.4
Maximum pre-fuses [A]	63		63		63		80	
Additional specifications								
IP20 maximum cable cross-section ²⁾ for mains, brake, motor, and load sharing [mm ² (AWG)]	10, 10, – (8, 8, –)		10, 10, – (8, 8, –)		10, 10, – (8, 8, –)		35, –, – (2, –, –)	
Protection rating IP21 maximum cable cross-section ²⁾ for mains, brake, and load sharing [mm ² (AWG)]	16, 10, 16 (6, 8, 6)		16, 10, 16 (6, 8, 6)		16, 10, 16 (6, 8, 6)		35, –, – (2, –, –)	
Protection rating IP21 maximum cable cross-section ²⁾ for motor [mm ² (AWG)]	10, 10, – (8, 8, –)		10, 10, – (8, 8, –)		10, 10, – (8, 8, –)		35, 25, 25 (2, 4, 4)	
Maximum cable cross-section ²⁾ for mains disconnect [mm ² (AWG)]	16, 10, 10 (6, 8, 8)						35 (2)	
Estimated power loss ³⁾ at rated maximum load [W (hp)] ⁴⁾	239 (0.33)	310 (0.42)	239 (0.33)	310 (0.42)	371 (0.51)	514 (0.7)	463 (0.63)	602 (0.82)
Efficiency ⁵⁾	0.96		0.96		0.96		0.96	

Table 8.4 Mains Supply 3x200–240 V AC, P5K5–P15K

Type designation	P18K		P22K		P30K		P37K		P45K	
High/normal overload ¹⁾	HO	NO	HO	NO	HO	NO	HO	NO	HO	NO
Typical shaft output [kW]	15	18.5	18.5	22	22	30	30	37	37	45
Typical shaft output at 208 V [hp]	20	25	25	30	30	40	40	50	50	60
Protection rating IP20/Chassis ⁷⁾	B4		C3		C3		C4		C4	
Protection rating IP21/Type 1										
Protection rating IP55/Type 12	C1		C1		C1		C2		C2	
Protection rating IP66/NEMA 4X										
Output current										
Continuous (3x200–240 V) [A]	59.4	74.8	74.8	88.0	88.0	115	115	143	143	170
Intermittent (3x200–240 V) [A]	89.1	82.3	112	96.8	132	127	173	157	215	187
Continuous kVA at 208 V [kVA]	21.4	26.9	26.9	31.7	31.7	41.4	41.4	51.5	51.5	61.2
Maximum input current										
Continuous (3x200–240 V) [A]	54.0	68.0	68.0	80.0	80.0	104	104	130	130	154.0
Intermittent (3x200–240 V) [A]	81.0	74.8	102	88.0	120	114	156	143	195	169.0
Maximum pre-fuses [A]	125		125		160		200		250	
Additional specifications										
Protection rating IP20 maximum cable cross-section for mains, brake, motor, and load sharing [mm ² (AWG)]	35 (2)		50 (1)		50 (1)		150 (300 MCM)		150 (300 MCM)	
Protection ratings IP21, IP55, IP66 maximum cable cross-section for mains and motor [mm ² (AWG)]	50 (1)		50 (1)		50 (1)		150 (300 MCM)		150 (300 MCM)	
Protection ratings IP21, IP55, IP66 maximum cable cross-section for brake, and load sharing [mm ² (AWG)]	50 (1)		50 (1)		50 (1)		95 (3/0)		95 (3/0)	
Maximum cable cross-section ²⁾ for disconnect [mm ² (AWG)]	50, 35, 35 (1, 2, 2)						95, 70, 70 (3/0, 2/0, 2/0)		185, 150, 120 (350 MCM, 300 MCM, 4/0)	
Estimated power loss ³⁾ at rated maximum load [W (hp)] ⁴⁾	624 (0.85)	737 (1)	740 (1)	845 (1.2)	874 (1.2)	1140 (1.6)	1143 (1.6)	1353 (1.8)	1400 (1.9)	1636 (2.2)
Efficiency ⁵⁾	0.96		0.97		0.97		0.97		0.97	

Table 8.5 Mains Supply 3x200–240 V AC, P18K–P45K

8.1.3 Mains Supply 1x380–480 V AC

Type designation	P7K5	P11K	P18K	P37K
Typical shaft output [kW]	7.5	11	18.5	37
Typical shaft output at 240 V [hp]	10	15	25	50
Protection rating IP21/Type 1	B1	B2	C1	C2
Protection rating IP55/Type 12	B1	B2	C1	C2
Protection rating IP66/NEMA 4X	B1	B2	C1	C2
Output current				
Continuous (3x380–440 V) [A]	16	24	37.5	73
Intermittent (3x380–440 V) [A]	17.6	26.4	41.2	80.3
Continuous (3x441–480 V) [A]	14.5	21	34	65
Intermittent (3x441–480 V) [A]	15.4	23.1	37.4	71.5
Continuous kVA at 400 V [kVA]	11.0	16.6	26	50.6
Continuous kVA at 460 V [kVA]	11.6	16.7	27.1	51.8
Maximum input current				
Continuous (1x380–440 V) [A]	33	48	78	151
Intermittent (1x380–440 V) [A]	36	53	85.5	166
Continuous (1x441–480 V) [A]	30	41	72	135
Intermittent (1x441–480 V) [A]	33	46	79.2	148
Maximum pre-fuses [A]	63	80	160	250
Additional specifications				
Maximum cable cross-section for mains, motor, and brake [mm ²] (AWG)]	10 (7)	35 (2)	50 (1/0)	120 (4/0)
Estimated power loss ³⁾ at rated maximum load [W (hp)] ⁴⁾	300 (0.41)	440 (0.6)	740 (1)	1480 (2)
Efficiency ⁵⁾	0.96	0.96	0.96	0.96

Table 8.6 Mains Supply 1x380–480 V AC, Normal Overload 110% for 1 Minute, P7K5–P37K

8.1.4 Mains Supply 3x380–480 V AC

Type designation	PK37		PK55		PK75		P1K1		P1K5	
	HO	NO	HO	NO	HO	NO	HO	NO	HO	NO
High/normal overload ¹⁾										
Typical shaft output [kW]	0.37		0.55		0.75		1.1		1.5	
Typical shaft output at 460 V [hp]	0.5		0.75		1.0		1.5		2.0	
Protection rating IP20/Chassis ⁶⁾	A2		A2		A2		A2		A2	
Protection rating IP55/Type 12	A4/A5		A4/A5		A4/A5		A4/A5		A4/A5	
Protection rating IP66/NEMA 4X	A4/A5		A4/A5		A4/A5		A4/A5		A4/A5	
Output current										
Continuous (3x380–440 V) [A]	1.3		1.8		2.4		3.0		4.1	
Intermittent (3x380–440 V) [A]	2.0	1.4	2.7	2.0	3.6	2.6	4.5	3.3	6.2	4.5
Continuous (3x441–480 V) [A]	1.2		1.6		2.1		2.7		3.4	
Intermittent (3x441–480 V) [A]	1.8	1.3	2.4	1.8	3.2	2.3	4.1	3.0	5.1	3.7
Continuous kVA at 400 V [kVA]	0.9		1.3		1.7		2.1		2.8	
Continuous kVA at 460 V [kVA]	0.9		1.3		1.7		2.4		2.7	
Maximum input current										
Continuous (3x380–440 V) [A]	1.2		1.6		2.2		2.7		3.7	
Intermittent (3x380–440 V) [A]	1.8	1.3	2.4	1.8	3.3	2.4	4.1	3.0	5.6	4.1
Continuous (3x441–480 V) [A]	1.0		1.4		1.9		2.7		3.1	
Intermittent (3x441–480 V) [A]	1.5	1.1	2.1	1.5	2.9	2.1	4.1	3.0	4.7	3.4
Maximum pre-fuses [A]	10		10		10		10		10	
Additional specifications										
Protection ratings IP20, IP21 maximum cable cross-section ²⁾ for mains, motor, brake, and load sharing [mm ² (AWG)]	4, 4, 4 (12, 12, 12) (minimum 0.2 (24))									
Protection ratings IP55, IP66 maximum cable cross-section ²⁾ for mains, motor, brake, and load sharing [mm ² (AWG)]	4, 4, 4 (12, 12, 12)									
Maximum cable cross-section ²⁾ for disconnect [mm ² (AWG)]	6, 4, 4 (10, 12, 12)									
Estimated power loss ³⁾ at rated maximum load [W (hp)] ⁴⁾	35 (0.05)		42 (0.06)		46 (0.06)		58 (0.08)		62 (0.08)	
Efficiency ⁵⁾	0.93		0.95		0.96		0.96		0.97	

Table 8.7 Mains Supply 3x380–480 V AC, PK37–P1K5

Type designation	P2K2		P3K0		P4K0		P5K5		P7K5	
	HO	NO	HO	NO	HO	NO	HO	NO	HO	NO
High/normal overload ¹⁾										
Typical shaft output [kW]	2.2		3.0		4.0		5.5		7.5	
Typical shaft output at 460 V [hp]	2.9		4.0		5.3		7.5		10	
Protection rating IP20/Chassis ⁶⁾	A2		A2		A2		A3		A3	
Protection rating IP55/Type 12	A4/A5		A4/A5		A4/A5		A5		A5	
Protection rating IP66/NEMA 4X	A4/A5		A4/A5		A4/A5		A5		A5	
Output current										
Continuous (3x380–440 V) [A]	5.6		7.2		10		13		16	
Intermittent (3x380–440 V) [A]	8.4	6.2	10.8	7.9	15.0	11.0	19.5	14.3	24.0	17.6
Continuous (3x441–480 V) [A]	4.8		6.3		8.2		11		14.5	
Intermittent (3x441–480 V) [A]	7.2	5.3	9.5	6.9	12.3	9.0	16.5	12.1	21.8	16.0
Continuous kVA at 400 V [kVA]	3.9		5.0		6.9		9.0		11.0	
Continuous kVA at 460 V [kVA]	3.8		5.0		6.5		8.8		11.6	
Maximum input current										
Continuous (3x380–440 V) [A]	5.0		6.5		9.0		11.7		14.4	
Intermittent (3x380–440 V) [A]	7.5	5.5	9.8	7.2	13.5	9.9	17.6	12.9	21.6	15.8
Continuous (3x441–480 V) [A]	4.3		5.7		7.4		9.9		13.0	
Intermittent (3x441–480 V) [A]	6.5	4.7	8.6	6.3	11.1	8.1	14.9	10.9	19.5	14.3
Maximum pre-fuses [A]	20		20		20		30		30	
Additional specifications										
Protection ratings IP20, IP21 maximum cable cross-section ²⁾ for mains, motor, brake, and load sharing [mm ² (AWG)]	4, 4, 4 (12, 12, 12) (minimum 0.2 (24))									
Protection ratings IP55, IP66 maximum cable cross-section ²⁾ for mains, motor, brake, and load sharing [mm ² (AWG)]	4, 4, 4 (12, 12, 12)									
Maximum cable cross-section ²⁾ for disconnect [mm ² (AWG)]	6, 4, 4 (10, 12, 12)									
Estimated power loss ³⁾ at rated maximum load [W (hp)] ⁴⁾	88 (0.12)		116 (0.16)		124 (0.17)		187 (0.25)		225 (0.31)	
Efficiency ⁵⁾	0.97		0.97		0.97		0.97		0.97	

Table 8.8 Mains Supply 3x380–480 V AC, P2K2–P7K5

Type designation	P11K		P15K		P18K		P22K		P30K	
High/normal overload ¹⁾	HO	NO	HO	NO	HO	NO	HO	NO	HO	NO
Typical shaft output [kW]	7.5	11	11	15	15	18.5	22.0	22.0	22.0	30
Typical shaft output at 460 V [hp]	10	15	15	20	20	25	30	30	30	40
Protection rating IP20/Chassis ⁷⁾	B3		B3		B3		B4			B4
Protection rating IP21/Type 1	B1		B1		B1		B2		B2	
Protection rating IP55/Type 12	B1		B1		B1		B2		B2	
Protection rating IP66/NEMA 4X	B1		B1		B1		B2		B2	
Output current										
Continuous (3x380–440 V) [A]	–	24	24	32	32	37.5	37.5	44	44	61
Intermittent (60 s overload) (3x380–440 V) [A]	–	26.4	38.4	35.2	51.2	41.3	60	48.4	70.4	67.1
Continuous (3x441–480 V) [A]	–	21	21	27	27	34	34	40	40	52
Intermittent (60 s overload) (3x441–480 V) [A]	–	23.1	33.6	29.7	43.2	37.4	54.4	44	64	61.6
Continuous kVA at 400 V [kVA]	–	16.6	16.6	22.2	22.2	26	26	30.5	30.5	42.3
Continuous kVA at 460 V [kVA]	–	16.7	16.7	21.5	21.5	27.1	27.1	31.9	31.9	41.4
Maximum input current										
Continuous (3x380–440 V) [A]	–	22	22	29	29	34	34	40	40	55
Intermittent (60 s overload) (3x380–440 V) [A]	–	24.2	35.2	31.9	46.4	37.4	54.4	44	64	60.5
Continuous (3x441–480 V) [A]	–	19	19	25	25	31	31	36	36	47
Intermittent (60 s overload) (3x441–480 V) [A]	–	20.9	30.4	27.5	40	34.1	49.6	39.6	57.6	51.7
Maximum pre-fuses [A]	–	63		63		63		63		80
Additional specifications										
Protection ratings IP21, IP55, IP66 maximum cable cross-section ²⁾ for mains, brake, and load sharing [mm ² (AWG)]	16, 10, 16 (6, 8, 6)						35, –, – (2, –, –)			
Protection ratings IP21, IP55, IP66 maximum cable cross-section ²⁾ for motor [mm ² (AWG)]	10, 10,– (8, 8,–)						35, 25, 25 (2, 4, 4)			
Protection rating IP20 maximum cable cross-section ²⁾ for mains, brake, motor, and load sharing [mm ² (AWG)]	10, 10,– (8, 8,–)						35, –, – (2, –, –)			
Maximum cable cross-section ²⁾ for disconnect [mm ² (AWG)]	16, 10, 10 (6, 8, 8)									
Estimated power loss ³⁾ at rated maximum load [W (hp)] ⁴⁾	291 (0.4)	392 (0.53)	291 (0.4)	392 (0.53)	379 (0.52)	465 (0.63)	444 (0.61)	525 (0.72)	547 (0.75)	739 (1)
Efficiency ⁵⁾	0.98		0.98		0.98		0.98		0.98	

Table 8.9 Mains Supply 3x380–480 V AC, P11K–P30K

Type designation	P37K		P45K		P55K		P75K		P90K	
High/normal overload ¹⁾	HO	NO	HO	NO	HO	NO	HO	NO	HO	NO
Typical shaft output [kW]	30	37	37	45	45	55	55	75	75	90
Typical shaft output at 460 V [hp]	40	50	50	60	60	75	75	100	100	125
Protection rating IP20/Chassis ⁶⁾	B4		C3		C3		C4		C4	
Protection rating IP21/Type 1	C1		C1		C1		C2		C2	
Protection rating IP55/Type 12	C1		C1		C1		C2		C2	
Protection rating IP66/NEMA 4X	C1		C1		C1		C2		C2	
Output current										
Continuous (3x380–440 V) [A]	61	73	73	90	90	106	106	147	147	177
Intermittent (60 s overload) (3x380–440 V) [A]	91.5	80.3	110	99	135	117	159	162	221	195
Continuous (3x441–480 V) [A]	52	65	65	80	80	105	105	130	130	160
Intermittent (60 s overload) (3x441–480 V) [A]	78	71.5	97.5	88	120	116	158	143	195	176
Continuous kVA at 400 V [kVA]	42.3	50.6	50.6	62.4	62.4	73.4	73.4	102	102	123
Continuous kVA at 460 V [kVA]	41.4	51.8	51.8	63.7	63.7	83.7	83.7	104	103.6	128
Maximum input current										
Continuous (3x380–440 V) [A]	55	66	66	82	82	96	96	133	133	161
Intermittent (60 s overload) (3x380–440 V) [A]	82.5	72.6	99	90.2	123	106	144	146	200	177
Continuous (3x441–480 V) [A]	47	59	59	73	73	95	95	118	118	145
Intermittent (60 s overload) (3x441–480 V) [A]	70.5	64.9	88.5	80.3	110	105	143	130	177	160
Maximum pre-fuses [A]	100		125		160		250		250	
Additional specifications										
Protection rating IP20 maximum cable cross-section for mains and motor [mm ² (AWG)]	35 (2)		50 (1)		50 (1)		150 (300 MCM)		150 (300 MCM)	
Protection rating IP20 maximum cable cross-section for brake and load sharing [mm ² (AWG)]	35 (2)		50 (1)		50 (1)		95 (4/0)		95 (4/0)	
Protection ratings IP21, IP55, IP66 maximum cable cross-section for mains and motor [mm ² (AWG)]	50 (1)		50 (1)		50 (1)		150 (300 MCM)		150 (300 MCM)	
Protection ratings IP21, IP55, IP66 maximum cable cross-section for brake and load sharing [mm ² (AWG)]	50 (1)		50 (1)		50 (1)		95 (3/0)		95 (3/0)	
Maximum cable cross-section ²⁾ for mains disconnect [mm ² (AWG)]			50, 35, 35 (1, 2, 2)				95, 70, 70 (3/0, 2/0, 2/0)		185, 150, 120 (350 MCM, 300 MCM, 4/0)	
Estimated power loss ³⁾ at rated maximum load [W (hp)] ⁴⁾	570 (0.78)	698 (0.95)	697 (0.95)	843 (1.1)	891 (1.2)	1083 (1.5)	1022 (1.4)	1384 (1.9)	1232 (1.7)	1474 (2)
Efficiency ⁵⁾	0.98		0.98		0.98		0.98		0.99	

Table 8.10 Mains Supply 3x380–480 V AC, P37K–P90K

8.1.5 Mains Supply 3x525–600 V AC

Type designation	PK75		P1K1		P1K5		P2K2	
	HO	NO	HO	NO	HO	NO	HO	NO
High/normal overload ¹⁾	HO	NO	HO	NO	HO	NO	HO	NO
Typical shaft output [kW]	0.75		1.1		1.5		2.2	
Typical shaft output [hp]	1		1.5		2		3	
Protection rating IP20/Chassis	A3		A3		A3		A3	
Protection rating IP21/Type 1	A3		A3		A3		A3	
Protection rating IP55/Type 12	A5		A5		A5		A5	
Output current								
Continuous (3x525–550 V) [A]	1.8		2.6		2.9		4.1	
Intermittent (3x525–550 V) [A]	2.7	2.0	3.9	2.9	4.4	3.2	6.2	4.5
Continuous (3x551–600 V) [A]	1.7		2.4		2.7		3.9	
Intermittent (3x551–600 V) [A]	2.6	1.9	3.6	2.6	4.1	3.0	5.9	4.3
Continuous kVA at 550 V [kVA]	1.7		2.5		2.8		3.9	
Continuous kVA at 550 V [kVA]	1.7		2.4		2.7		3.9	
Maximum input current								
Continuous (3x525–600 V) [A]	1.7		2.4		2.7		4.1	
Intermittent (3x525–600 V) [A]	2.6	1.9	3.6	2.6	4.1	3.0	6.2	4.5
Maximum pre-fuses [A]	10		10		10		20	
Additional specifications								
Maximum cable cross-section ²⁾ for mains, motor, brake, and load sharing [mm ² (AWG)]	4,4,4 (12,12,12) (minimum 0.2 (24))							
Maximum cable cross-section ²⁾ for mains disconnect [mm ² (AWG)]	6,4,4 (10,12,12)							
Estimated power loss ³⁾ at rated maximum load [W (hp)] ⁴⁾	35 (0.05)		50 (0.07)		65 (0.09)		92 (0.13)	
Efficiency ⁵⁾	0.97		0.97		0.97		0.97	

Table 8.11 Mains Supply 3x525–600 V AC, PK75–P2K2

Type designation	P3K0		P4K0		P5K5		P7K5	
	HO	NO	HO	NO	HO	NO	HO	NO
High/normal overload ¹⁾	HO	NO	HO	NO	HO	NO	HO	NO
Typical shaft output [kW]	3.0		4.0		5.5		7.5	
Typical shaft output [hp]	4		5		7.5		10	
Protection rating IP20/Chassis Protection rating IP21/Type 1	A2		A2		A3		A3	
IP55/Type 12	A5		A5		A5		A5	
Output current								
Continuous (3x525–550 V) [A]	5.2		6.4		9.5		11.5	
Intermittent (3x525–550 V) [A]	7.8	5.7	9.6	7.0	14.3	10.5	17.3	12.7
Continuous (3x551–600 V) [A]	4.9		6.1		9.0		11.0	
Intermittent (3x551–600 V) [A]	7.4	5.4	9.2	6.7	13.5	9.9	16.5	12.1
Continuous kVA at 550 V [kVA]	5.0		6.1		9.0		11.0	
Continuous kVA at 550 V [kVA]	4.9		6.1		9.0		11.0	
Maximum input current								
Continuous (3x525–600 V) [A]	5.2		5.8		8.6		10.4	
Intermittent (3x525–600 V) [A]	7.8	5.7	8.7	6.4	12.9	9.5	15.6	11.4
Maximum pre-fuses [A]	20		20		32		32	
Additional specifications								
Maximum cable cross-section ²⁾ for mains, motor, brake, and load sharing [mm ² (AWG)]	4,4,4 (12,12,12) (minimum 0.2 (24))							
Maximum cable cross-section ²⁾ for mains disconnect [mm ² (AWG)]	6,4,4 (10,12,12)							
Estimated power loss ³⁾ at rated maximum load [W (hp)] ⁴⁾	122 (0.17)		145 (0.2)		195 (0.27)		261 (0.36)	
Efficiency ⁵⁾	0.97		0.97		0.97		0.97	

Table 8.12 Mains Supply 3x525–600 V AC, P3K0–P7K5

Type designation	P11K		P15K		P18K		P22K		P30K		P37K	
	HO	NO	HO	NO	HO	NO	HO	NO	HO	NO	HO	NO
High/normal overload ¹⁾	HO	NO	HO	NO	HO	NO	HO	NO	HO	NO	HO	NO
Typical shaft output [kW]	7.5	11	11	15	15	18.5	18.5	22	22	30	30	37
Typical shaft output [hp]	10	15	15	20	20	25	25	30	30	40	40	50
Protection rating IP20/ Chassis	B3		B3		B3		B4		B4		B4	
Protection rating IP21/ Type 1 Protection rating IP55/ Type 12 Protection rating IP66/ NEMA 4X	B1		B1		B1		B2		B2		C1	
Output current												
Continuous (3x525–550 V) [A]	11.5	19	19	23	23	28	28	36	36	43	43	54
Intermittent (3x525– 550 V) [A]	18.4	21	30	25	37	31	45	40	58	47	65	59
Continuous (3x551–600 V) [A]	11	18	18	22	22	27	27	34	34	41	41	52
Intermittent (3x551– 600 V) [A]	17.6	20	29	24	35	30	43	37	54	45	62	57
Continuous kVA at 550 V [kVA]	11	18.1	18.1	21.9	21.9	26.7	26.7	34.3	34.3	41.0	41.0	51.4
Continuous kVA at 575 V [kVA]	11	17.9	17.9	21.9	21.9	26.9	26.9	33.9	33.9	40.8	40.8	51.8
Maximum input current												
Continuous at 550 V [A]	10.4	17.2	17.2	20.9	20.9	25.4	25.4	32.7	32.7	39	39	49
Intermittent at 550 V [A]	16.6	19	28	23	33	28	41	36	52	43	59	54
Continuous at 575 V [A]	9.8	16	16	20	20	24	24	31	31	37	37	47
Intermittent at 575 V [A]	15.5	17.6	26	22	32	27	39	34	50	41	56	52
Maximum pre-fuses [A]	40		40		50		60		80		100	
Additional specifications												
Protection rating IP20, maximum cable cross- section ²⁾ for mains, brake, motor, and load sharing [mm ² (AWG)]	10, 10,- (8, 8,-)						35,-,- (2,-,-)					
Protection ratings IP21, IP55, IP66 maximum cable cross-section ²⁾ for mains, brake, and load sharing [mm ² (AWG)]	16, 10, 10 (6, 8, 8)						35,-,- (2,-,-)					
Protection ratings IP21, IP55, IP66 maximum cable cross-section ²⁾ for motor [mm ² (AWG)]	10, 10,- (8, 8,-)						35, 25, 25 (2, 4, 4)					
Maximum cable cross- section ²⁾ for mains disconnect [mm ² (AWG)]	16, 10, 10 (6, 8, 8)						50, 35, 35 (1, 2, 2)					
Estimated power loss ³⁾ at rated maximum load [W (hp)] ⁴⁾	220 (0.3)	300 (0.41)	220 (0.3)	300 (0.41)	300 (0.41)	370 (0.5)	370 (0.5)	440 (0.6)	440 (0.6)	600 (0.82)	600 (0.82)	740 (1)
Efficiency ⁵⁾	0.98		0.98		0.98		0.98		0.98		0.98	

Table 8.13 Mains supply 3x525–600 V AC, P11K–P37K

Type designation	P45K		P55K		P75K		P90K	
High/normal overload ¹⁾	HO	NO	HO	NO	HO	NO	HO	NO
Typical shaft output [kW]	37	45	45	55	55	75	75	90
Typical shaft output [hp]	50	60	60	75	75	100	100	125
Protection rating IP20/Chassis	C3		C3		C4		C4	
Protection rating IP21/Type 1								
Protection rating IP55/Type 12	C1		C1		C2		C2	
Protection rating IP66/NEMA 4X								
Output current								
Continuous (3x525–550 V) [A]	54	65	65	87	87	105	105	137
Intermittent (3x525–550 V) [A]	81	72	98	96	131	116	158	151
Continuous (3x525–600 V) [A]	52	62	62	83	83	100	100	131
Intermittent (3x525–600 V) [A]	78	68	93	91	125	110	150	144
Continuous kVA at 525 V [kVA]	51.4	61.9	61.9	82.9	82.9	100	100.0	130.5
Continuous kVA at 575 V [kVA]	51.8	61.7	61.7	82.7	82.7	99.6	99.6	130.5
Maximum input current								
Continuous at 550 V [A]	49	59	59	78.9	78.9	95.3	95.3	124.3
Intermittent at 550 V [A]	74	65	89	87	118	105	143	137
Continuous at 575 V [A]	47	56	56	75	75	91	91	119
Intermittent at 575 V [A]	70	62	85	83	113	100	137	131
Maximum pre-fuses [A]	150		160		225		250	
Additional specifications								
Protection rating IP20 maximum cable cross-section for mains and motor [mm ² (AWG)]	50 (1)				150 (300 MCM)			
Protection rating IP20 maximum cable cross-section for brake and load sharing [mm ² (AWG)]	50 (1)				95 (4/0)			
Protection ratings IP21, IP55, IP66 maximum cable cross-section for mains and motor [mm ² (AWG)]	50 (1)				150 (300 MCM)			
Protection ratings IP21, IP55, IP66 maximum cable cross-section for brake and load sharing [mm ² (AWG)]	50 (1)				95 (4/0)			
Maximum cable cross-section ²⁾ for mains disconnect [mm ² (AWG)]	50, 35, 35 (1, 2, 2)				95, 70, 70 (3/0, 2/0, 2/0)		185, 150, 120 (350 MCM, 300 MCM, 4/0)	
Estimated power loss ³⁾ at rated maximum load [W (hp)] ⁴⁾	740 (1)	900 (1.2)	900 (1.2)	1100 (1.5)	1100 (1.5)	1500 (2)	1500 (2)	1800 (2.5)
Efficiency ⁵⁾	0.98		0.98		0.98		0.98	

Table 8.14 Mains supply 3x525–600 V AC, P45K–P90K

8.1.6 Mains Supply 3x525–690 V AC

Type designation	P1K1		P1K5		P2K2		P3K0		P4K0		P5K5		P7K5	
High/normal overload ¹⁾	HO	NO	HO	NO	HO	NO	HO	NO	HO	NO	HO	NO	HO	NO
Typical shaft output [kW]	1.1		1.5		2.2		3.0		4.0		5.5		7.5	
Typical shaft output [hp]	1.5		2		3		4		5		7.5		10	
IP20/Chassis	A3		A3		A3		A3		A3		A3		A3	
Output current														
Continuous (3x525–550 V) [A]	2.1		2.7		3.9		4.9		6.1		9.0		11.0	
Intermittent (3x525–550 V) [A]	3.2	2.3	4.1	3.0	5.9	4.3	7.4	5.4	9.2	6.7	13.5	9.9	16.5	12.1
Continuous (3x551–690 V) [A]	1.6		2.2		3.2		4.5		5.5		7.5		10.0	
Intermittent (3x551–690 V) [A]	2.4	1.8	3.3	2.4	4.8	3.5	6.8	5.0	8.3	6.1	11.3	8.3	15.0	11.0
Continuous kVA at 525 V [kVA]	1.9		2.5		3.5		4.5		5.5		8.2		10.0	
Continuous kVA at 690 V [kVA]	1.9		2.6		3.8		5.4		6.6		9.0		12.0	
Maximum input current														
Continuous (3x525–550 V) [A]	1.9		2.4		3.5		4.4		5.5		8.1		9.9	
Intermittent (3x525–550 V) [A]	2.9	2.1	3.6	2.6	5.3	3.9	6.6	4.8	8.3	6.1	12.2	8.9	14.9	10.9
Continuous (3x551–690 V) [A]	1.4		2.0		2.9		4.0		4.9		6.7		9.0	
Intermittent (3x551–690 V) [A]	2.1	1.5	3.0	2.2	4.4	3.2	6.0	4.4	7.4	5.4	10.1	7.4	13.5	9.9
Additional specifications														
Maximum cable cross-section ²⁾ for mains, motor, brake, and load sharing [mm ² (AWG)]	4, 4, 4 (12, 12, 12) (minimum (24))													
Maximum cable cross-section ²⁾ for mains disconnect [mm ² (AWG)]	6, 4, 4 (10, 12, 12)													
Estimated power loss ³⁾ at rated maximum load [W (hp)] ⁴⁾	44 (0.06)		60 (0.08)		88 (0.12)		120 (0.16)		160 (0.22)		220 (0.3)		300 (0.41)	
Efficiency ⁵⁾	0.96		0.96		0.96		0.96		0.96		0.96		0.96	

8

Table 8.15 A3 Enclosure, Mains Supply 3x525–690 V AC IP20/Protected Chassis, P1K1–P7K5

Type designation	P11K		P15K		P18K		P22K		P30K	
High/normal overload ¹⁾	HO	NO	HO	NO	HO	NO	HO	NO	HO	NO
Typical shaft output at 550 V [kW]	5.9	7.5	7.5	11	11	15	15	18.5	18.5	22
Typical shaft output at 550 V [hp]	7.5	10	10	15	15	20	20	25	25	30
Typical shaft output at 690 V [kW]	7.5	11	11	15	15	18.5	18.5	22	22	30
Typical shaft output at 690 V [hp]	10	15	15	20	20	25	25	30	30	40
IP20/Chassis	B4		B4		B4		B4		B4	
IP21/Type 1										
IP55/Type 12	B2		B2		B2		B2		B2	
Output current										
Continuous (3x525–550 V) [A]	11	14	14.0	19.0	19.0	23.0	23.0	28.0	28.0	36.0
Intermittent (60 s overload) (3x525–550 V) [A]	17.6	15.4	22.4	20.9	30.4	25.3	36.8	30.8	44.8	39.6
Continuous (3x551–690 V) [A]	10	13	13.0	18.0	18.0	22.0	22.0	27.0	27.0	34.0
Intermittent (60 s overload) (3x551–690 V) [A]	16	14.3	20.8	19.8	28.8	24.2	35.2	29.7	43.2	37.4
Continuous kVA at 550 V [kVA]	10	13.3	13.3	18.1	18.1	21.9	21.9	26.7	26.7	34.3
Continuous kVA at 690 V [kVA]	12	15.5	15.5	21.5	21.5	26.3	26.3	32.3	32.3	40.6
Maximum input current										
Continuous at 550 V [A]	9.9	15	15.0	19.5	19.5	24.0	24.0	29.0	29.0	36.0
Intermittent (60 s overload) at 550 V [A]	15.8	16.5	23.2	21.5	31.2	26.4	38.4	31.9	46.4	39.6
Continuous (at 690 V) [A]	9	14.5	14.5	19.5	19.5	24.0	24.0	29.0	29.0	36.0
Intermittent (60 s overload) at 690 V [A]	14.4	16	23.2	21.5	31.2	26.4	38.4	31.9	46.4	39.6
Additional specifications										
Maximum cable cross-section ²⁾ for mains, motor, brake, and load sharing [mm ² (AWG)]	35, 25, 25 (2, 4, 4)									
Maximum cable cross-section ²⁾ for mains disconnect [mm ² (AWG)]	16,10,10 (6, 8, 8)									
Estimated power loss ³⁾ at rated maximum load [W (hp)] ⁴⁾	150 (0.2)	220 (0.3)	150 (0.2)	220 (0.3)	220 (0.3)	300 (0.41)	300 (0.41)	370 (0.5)	370 (0.5)	440 (0.6)
Efficiency ⁵⁾	0.98		0.98		0.98		0.98		0.98	

Table 8.16 B2/B4 Enclosure, Mains Supply 3x525–690 V AC IP20/IP21/IP55 – Chassis/NEMA 1/NEMA 12, P11K–P22K

Type designation	P37K		P45K		P55K		P75K/N75K ⁸⁾		P90K/N90K ⁸⁾	
High/normal overload ¹⁾	HO	NO	HO	NO	HO	NO	HO	NO	HO	NO
Typical shaft output at 550 V [kW]	22	30	30	37	37	45	45	55	55	75
Typical shaft output at 550 V [hp]	30	40	40	50	50	60	60	75	75	100
Typical shaft output at 690 V [kW]	30	37	37	45	45	55	55	75	75	90
Typical shaft output at 690 V [hp]	40	50	50	60	60	75	75	100	199	125
IP20/Chassis	B4		C3		C3		D3h		D3h	
IP21/Type 1										
IP55/Type 12	C2		C2		C2		C2		C2	
Output current										
Continuous (3x525–550 V) [A]	36.0	43.0	43.0	54.0	54.0	65.0	65.0	87.0	87.0	105
Intermittent (60 s overload) (3x525–550 V) [A]	54.0	47.3	64.5	59.4	81.0	71.5	97.5	95.7	130.5	115.5
Continuous (3x551–690 V) [A]	34.0	41.0	41.0	52.0	52.0	62.0	62.0	83.0	83.0	100
Intermittent (60 s overload) (3x551–690 V) [A]	51.0	45.1	61.5	57.2	78.0	68.2	93.0	91.3	124.5	110
Continuous kVA at 550 V [kVA]	34.3	41.0	41.0	51.4	51.4	61.9	61.9	82.9	82.9	100
Continuous kVA at 690 V [kVA]	40.6	49.0	49.0	62.1	62.1	74.1	74.1	99.2	99.2	119.5
Maximum input current										
Continuous at 550 V [A]	36.0	49.0	49.0	59.0	59.0	71.0	71.0	87.0	87.0	99.0
Intermittent (60 s overload) at 550 V [A]	54.0	53.9	72.0	64.9	87.0	78.1	105.0	95.7	129	108.9
Continuous at 690 V [A]	36.0	48.0	48.0	58.0	58.0	70.0	70.0	86.0	–	–
Intermittent (60 s overload) at 690 V [A]	54.0	52.8	72.0	63.8	87.0	77.0	105	94.6	–	–
Additional specifications										
Maximum cable cross-section for mains and motor [mm ² (AWG)]	150 (300 MCM)									
Maximum cable cross-section for brake and load sharing [mm ² (AWG)]	95 (3/0)									
Maximum cable cross-section ²⁾ for mains disconnect [mm ² (AWG)]	95 (3/0)						185, 150, 120 (350 MCM, 300 MCM, 4/0)		–	
Estimated power loss ³⁾ at rated maximum load [W (hp)] ⁴⁾	600 (0.82)	740 (1)	740 (1)	900 (1.2)	900 (1.2)	1100 (1.5)	1100 (1.5)	1500 (2)	1500 (2)	1800 (2.5)
Efficiency ⁵⁾	0.98		0.98		0.98		0.98		0.98	

Table 8.17 B4, C2, C3 Enclosure, Mains Supply 3x525–690 V AC IP20/IP21/IP55 – Chassis/NEMA1/NEMA 12, P30K–P75K

For fuse ratings see chapter 8.8 Fuses and Circuit Breakers.

1) High overload=150% or 160% torque for a duration of 60 s. Normal overload=110% torque for a duration of 60 s.

2) The 3 values for the maximum cable cross-section are for single core, flexible wire, and flexible wire with sleeve, respectively.

3) Applies for dimensioning of frequency converter cooling. If the switching frequency is higher than the default setting, the power losses may increase. LCP and typical control card power consumptions are included.

4) Efficiency measured at nominal current. For energy efficiency class see chapter 8.4.1 Ambient Conditions.

5) Measured using 5 m (16 ft) shielded motor cables at rated load and rated frequency.

6) Enclosure sizes A2+A3 can be converted to IP21 using a conversion kit. See also chapters Mechanical mounting and IP21/Type 1 Enclosure kit in the design guide.

7) Enclosure sizes B3+B4 and C3+C4 can be converted to IP21 using a conversion kit. See also chapters Mechanical mounting and IP21/Type 1 Enclosure kit in the design guide.

8) Enclosure sizes for N75K, N90K are D3h for IP20/Chassis, and D5h for IP54/Type 12.

9) Two wires are required.

10) Variant not available in IP21.

8.2 Mains Supply

Mains supply (L1, L2, L3)

Supply voltage	200–240 V $\pm 10\%$
Supply voltage	380–480 V $\pm 10\%$
Supply voltage	525–600 V $\pm 10\%$
Supply voltage	525–690 V $\pm 10\%$

Mains voltage low/mains drop-out:

During low mains voltage or a mains drop-out, the frequency converter continues until the DC-link voltage drops below the minimum stop level. Typically, this corresponds to 15% below the lowest rated supply voltage of the frequency converter. Power-up and full torque cannot be expected at mains voltage <10% below the lowest rated supply voltage of the frequency converter.

Supply frequency	50/60 Hz +4/-6%
------------------	-----------------

The frequency converter power supply is tested in accordance with IEC61000-4-28, 50 Hz +4/-6%.

Maximum imbalance temporary between mains phases	3.0% of rated supply voltage
True power factor (λ)	≥ 0.9 nominal at rated load
Displacement power factor ($\cos\phi$) near unity	(>0.98)
Switching on input supply L1, L2, L3 (power-ups) ≤ 7.5 kW (10 hp)	Maximum 2 times/minute
Switching on input supply L1, L2, L3 (power-ups) 11–90 kW (15–125 hp)	Maximum 1 time/minute
Environment according to EN 60664-1	Overvoltage category III/pollution degree 2

The unit is suitable for use on a circuit capable of delivering not more than 100000 RMS symmetrical Amperes, 240/480/600/690 V maximum.

8

8.3 Motor Output and Motor Data

Motor output (U, V, W)

Output voltage	0–100% of supply voltage
Output frequency	0–590 Hz ¹⁾
Switching on output	Unlimited
Ramp times	1–3600 s

1) Dependent on power size.

Torque characteristics, normal overload

Starting torque (constant torque)	Maximum 110% for 1 minute, once in 10 minutes ²⁾
Overload torque (constant torque)	Maximum 110% for 1 minute, once in 10 minutes ²⁾

Torque characteristics, high overload

Starting torque (constant torque)	Maximum 150/160% for 1 minute, once in 10 minutes ²⁾
Overload torque (constant torque)	Maximum 150/160% for 1 minute, once in 10 minutes ²⁾

2) Percentage relates to the nominal torque of the frequency converter, dependent on power size.

8.4 Ambient Conditions

Environment

Enclosure size A	IP20/Chassis, IP21/Type 1, IP55/Type 12, IP66/Type 4X
Enclosure size B1/B2	IP21/Type 1, IP55/Type 12, IP66/Type 4X
Enclosure size B3/B4	IP20/Chassis
Enclosure size C1/C2	IP21/Type 1, IP55/Type 12, IP66/Type 4X
Enclosure size C3/C4	IP20/Chassis
Enclosure kit available ≤ enclosure size A	IP21/TYPE 1/IP4X top
Vibration test enclosure A/B/C	1.0 g
Maximum relative humidity	5–95% (IEC 721-3-3; Class 3K3 (non-condensing) during operation
Aggressive environment (IEC 721-3-3), uncoated	Class 3C2
Aggressive environment (IEC 721-3-3), coated	Class 3C3
Test method according to IEC 60068-2-43 H2S (10 days)	
Ambient temperature	Maximum 50 °C (122 °F)

Derating for high ambient temperature, see chapter Special Conditions in the design guide.

Minimum ambient temperature during full-scale operation	0 °C (32 °F)
Minimum ambient temperature at reduced performance	-10 °C (14 °F)
Temperature during storage/transport	-25 to +65/70 °C (-13 to 149/158 °F)
Maximum altitude above sea level without derating	1000 m (3281 ft)
Maximum altitude above sea level with derating	3000 m (9843 ft)

Derating for high altitude, see chapter Special Conditions in the design guide.

EMC standards, Emission	EN 61800-3
EMC standards, Immunity	EN 61800-3
Energy efficiency class ¹⁾	IE2

1) Determined according to EN50598-2 at:

- Rated load.
- 90% rated frequency.
- Switching frequency factory setting.
- Switching pattern factory setting.

8.5 Cable Specifications

Maximum motor cable length, shielded/armored	150 m (492 ft)
Maximum motor cable length, unshielded/unarmored	300 m (984 ft)
Maximum cross-section to motor, mains, load sharing, and brake ¹⁾	
Maximum cross-section to control terminals, rigid wire	1.5 mm ² or 2 x 0.75 mm ² (16 AWG)
Maximum cross-section to control terminals, flexible cable	1 mm ² (18 AWG)
Maximum cross-section to control terminals, cable with enclosed core	0.5 mm ² (20 AWG)
Minimum cross-section to control terminals	0.25 mm ² (24 AWG)

1) See electrical data tables in chapter 8.1 Electrical Data for more information.

It is mandatory to ground the mains connection properly using T95 (PE) of the frequency converter. The ground connection cable cross-section must be at least 10 mm² (8 AWG) or 2 rated mains wires terminated separately according to EN 50178. See also chapter 4.3.1 Grounding. Use unshielded cable.

8.6 Control Input/Output and Control Data

Control card, RS485 serial communication

Terminal number	68 (PTX+, RX+), 69 (NTX-, RX-)
Terminal number 61	Common for terminals 68 and 69

The RS485 serial communication circuit is functionally separated from other central circuits and galvanically isolated from the supply voltage (PELV).

Analog inputs

Number of analog inputs	2
Terminal number	53, 54
Modes	Voltage or current
Mode select	Switches S201 and S202
Voltage mode	Switch S201/S202 = OFF (U)
Voltage level	0–10 V (scaleable)
Input resistance, R_i	Approximately 10 k Ω
Maximum voltage	± 20 V
Current mode	Switch S201/S202=On (I)
Current level	0/4–20 mA (scaleable)
Input resistance, R_i	Approximately 200 Ω
Maximum current	30 mA
Resolution for analog inputs	10 bit (+ sign)
Accuracy of analog inputs	Maximum error 0.5% of full scale
Bandwidth	200 Hz

The analog inputs are galvanically isolated from the supply voltage (PELV) and other high-voltage terminals.

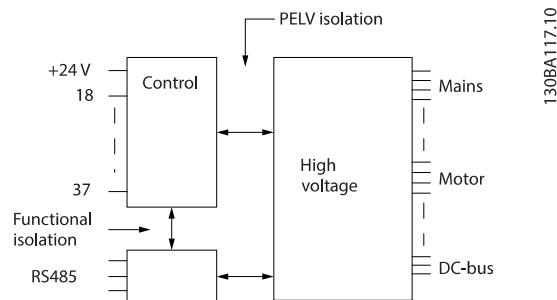

Illustration 8.1 PELV Isolation of Analog Inputs

Analog output

Number of programmable analog outputs	1
Terminal number	42
Current range at analog output	0/4–20 mA
Maximum resistor load to common at analog output	500 Ω
Accuracy on analog output	Maximum error 0.8% of full scale
Resolution on analog output	8 bit

The analog output is galvanically isolated from the supply voltage (PELV) and other high-voltage terminals.

Digital inputs

Programmable digital inputs	4 (6)
Terminal number	18, 19, 27 ¹⁾ , 29 ¹⁾ , 32, 33,
Logic	PNP or NPN
Voltage level	0–24 V DC
Voltage level, logic 0 PNP	<5 V DC
Voltage level, logic 1 PNP	>10 V DC
Voltage level, logic 0 NPN	>19 V DC
Voltage level, logic 1 NPN	<14 V DC
Maximum voltage on input	28 V DC
Input resistance, R_i	Approximately 4 k Ω

All digital inputs are galvanically isolated from the supply voltage (PELV) and other high-voltage terminals.

1) Terminals 27 and 29 can also be programmed as output.

Digital output

Programmable digital/pulse outputs	2
Terminal number	27, 29 ¹⁾
Voltage level at digital/frequency output	0–24 V
Maximum output current (sink or source)	40 mA
Maximum load at frequency output	1 kΩ
Maximum capacitive load at frequency output	10 nF
Minimum output frequency at frequency output	0 Hz
Maximum output frequency at frequency output	32 kHz
Accuracy of frequency output	Maximum error 0.1% of full scale
Resolution of frequency outputs	12 bit

1) Terminal 27 and 29 can also be programmed as input.

The digital output is galvanically isolated from the supply voltage (PELV) and other high-voltage terminals.

Pulse inputs

Programmable pulse inputs	2
Terminal number pulse	29, 33
Maximum frequency at terminal 29, 33	110 kHz (push-pull driven)
Maximum frequency at terminal 29, 33	5 kHz (open collector)
Minimum frequency at terminal 29, 33	4 Hz
Voltage level	See <i>Digital inputs</i>
Maximum voltage on input	28 V DC
Input resistance, R _i	Approximately 4 kΩ
Pulse input accuracy (0.1–1 kHz)	Maximum error 0.1% of full scale

Control card, 24 V DC output

Terminal number	12, 13
Maximum load	200 mA

The 24 V DC supply is galvanically isolated from the supply voltage (PELV), but has the same potential as the analog and digital inputs and outputs.

Relay outputs

Programmable relay outputs	2
Relay 01 terminal number	1-3 (break), 1-2 (make)
Maximum terminal load (AC-1) ¹⁾ on 1-3 (NC), 1-2 (NO) (resistive load)	240 V AC, 2 A
Maximum terminal load (AC-15) ¹⁾ (inductive load @ cosφ 0.4)	240 V AC, 0.2 A
Maximum terminal load (DC-1) ¹⁾ on 1-2 (NO), 1-3 (NC) (resistive load)	60 V DC, 1 A
Maximum terminal load (DC-13) ¹⁾ (inductive load)	24 V DC, 0.1 A
Relay 02 terminal number	4-6 (break), 4-5 (make)
Maximum terminal load (AC-1) ¹⁾ on 4-5 (NO) (resistive load) ^{2) 3)}	400 V AC, 2 A
Maximum terminal load (AC-15) ¹⁾ on 4-5 (NO) (inductive load @ cosφ 0.4)	240 V AC, 0.2 A
Maximum terminal load (DC-1) ¹⁾ on 4-5 (NO) (resistive load)	80 V DC, 2 A
Maximum terminal load (DC-13) ¹⁾ on 4-5 (NO) (inductive load)	24 V DC, 0.1 A
Maximum terminal load (AC-1) ¹⁾ on 4-6 (NC) (resistive load)	240 V AC, 2 A
Maximum terminal load (AC-15) ¹⁾ on 4-6 (NC) (inductive load @ cosφ 0.4)	240 V AC, 0.2 A
Maximum terminal load (DC-1) ¹⁾ on 4-6 (NC) (resistive load)	50 V DC, 2 A
Maximum terminal load (DC-13) ¹⁾ on 4-6 (NC) (inductive load)	24 V DC, 0.1 A
Minimum terminal load on 1-3 (NC), 1-2 (NO), 4-6 (NC), 4-5 (NO)	24 V DC, 10 mA, 24 V AC, 20 mA
Environment according to EN 60664-1	Overvoltage category III/pollution degree 2

1) IEC 60947 parts 4 and 5.

The relay contacts are galvanically isolated from the rest of the circuit by reinforced isolation (PELV).

2) Overvoltage category II.

3) UL applications 300 V AC 2 A.

Control card, 10 V DC output

Terminal number	50
Output voltage	10.5 V ±0.5 V
Maximum load	25 mA

The 10 V DC supply is galvanically isolated from the supply voltage (PELV) and other high-voltage terminals.

Control characteristics

Resolution of output frequency at 0–590 Hz	±0.003 Hz
System response time (terminals 18, 19, 27, 29, 32, 33)	≤2 ms
Speed control range (open loop)	1:100 of synchronous speed
Speed accuracy (open loop)	30–4000 RPM: Maximum error of ±8 RPM

All control characteristics are based on a 4-pole asynchronous motor.

Control card performance

Scan interval	5 ms
---------------	------

Control card, USB serial communication

USB standard	1.1 (full speed)
USB plug	USB type B "device" plug

NOTICE

Connection to a PC is carried out via a standard host/device USB cable.

The USB connection is galvanically isolated from the supply voltage (PELV) and other high-voltage terminals.

The USB connection is not galvanically isolated from protective earth. Use only an isolated laptop/PC as a connection to the USB connector on the frequency converter, or an isolated USB cable/converter.

8

8.7 Connection Tightening Torques

Enclosure	Torque [N•m (in-lb)]					
	Mains	Motor	DC connection	Brake	Ground	Ground
A2	1.8 (16)	1.8 (16)	1.8 (16)	1.8 (16)	3 (27)	0.6 (5)
A3	1.8 (16)	1.8 (16)	1.8 (16)	1.8 (16)	3 (27)	0.6 (5)
A4	1.8 (16)	1.8 (16)	1.8 (16)	1.8 (16)	3 (27)	0.6 (5)
A5	1.8 (16)	1.8 (16)	1.8 (16)	1.8 (16)	3 (27)	0.6 (5)
B1	1.8 (16)	1.8 (16)	1.5 (13)	1.5 (13.3)	3 (27)	0.6 (5)
B2	4.5 (40)	4.5 (40)	3.7 (33)	3.7 (33)	3 (27)	0.6 (5)
B3	1.8 (16)	1.8 (16)	1.8 (16)	1.8 (16)	3 (27)	0.6 (5)
B4	4.5 (40)	4.5 (40)	4.5 (40)	4.5 (40)	3 (27)	0.6 (5)
C1	10 (89)	10 (89)	10 (89)	10 (89)	3 (27)	0.6 (5)
C2	14/24 (124/221) ¹⁾	14/24 (124/221) ¹⁾	14 (124)	14 (124)	3 (27)	0.6 (5)
C3	10 (89)	10 (89)	10 (89)	10 (89)	3 (27)	0.6 (5)
C4	14/24 (124/221) ¹⁾	14/24 (124/221) ¹⁾	14 (124)	14 (124)	3 (27)	0.6 (5)

Table 8.18 Terminal Tightening Torques

1) For different cable dimensions x/y, where x≤95 mm² (3 AWG) and y≥95 mm² (3 AWG).

8.8 Fuses and Circuit Breakers

Use recommended fuses and/or circuit breakers on the supply side as protection if there is component break-down inside the frequency converter (first fault).

NOTICE

Use of fuses on the supply side is mandatory for IEC 60364 (CE) and NEC 2009 (UL) compliant installations.

Recommendations

- gG type fuses.
- Moeller type circuit breakers. For other circuit breaker types, ensure that the energy into the frequency converter is equal to or lower than the energy provided by Moeller types.

Use of recommended fuses and circuit breakers ensures that possible damage to the frequency converter is limited to damage inside the unit. For further information, see *Application Note Fuses and Circuit Breakers*.

The fuses in *chapter 8.8.1 CE Compliance* to *chapter 8.8.2 UL Compliance* are suitable for use on a circuit capable of delivering 100000 A_{rms} (symmetrical), depending on the frequency converter voltage rating. With the proper fusing, the frequency converter short circuit current rating (SCCR) is 100000 A_{rms}.

8.8.1 CE Compliance



Enclosure	Power [kW (hp)]	Recommended fuse size	Recommended maximum fuse	Recommended circuit breaker Moeller	Maximum trip level [A]
A2	0.25–2.2 (0.34–3)	gG-10 (0.25–1.5) gG-16 (2.2)	gG-25	PKZM0-25	25
A3	3.0–3.7 (4–5)	gG-16 (3) gG-20 (3.7)	gG-32	PKZM0-25	25
A4	0.25–2.2 (0.34–3)	gG-10 (0.25–1.5) gG-16 (2.2)	gG-32	PKZM0-25	25
A5	0.25–3.7 (0.34–5)	gG-10 (0.25–1.5) gG-16 (2.2–3) gG-20 (3.7)	gG-32	PKZM0-25	25
B1	5.5–11 (7.5–15)	gG-25 (5.5) gG-32 (7.5)	gG-80	PKZM4-63	63
B2	15 (20)	gG-50	gG-100	NZMB1-A100	100
B3	5.5–11 (7.5–15)	gG-25	gG-63	PKZM4-50	50
B4	15–18 (20–24)	gG-32 (7.5) gG-50 (11) gG-63 (15)	gG-125	NZMB1-A100	100
C1	18.5–30 (25–40)	gG-63 (15) gG-80 (18.5) gG-100 (22)	gG-160 (15–18.5) aR-160 (22)	NZMB2-A200	160
C2	37–45 (50–60)	aR-160 (30) aR-200 (37)	aR-200 (30) aR-250 (37)	NZMB2-A250	250
C3	22–30 (30–40)	gG-80 (18.5) aR-125 (22)	gG-150 (18.5) aR-160 (22)	NZMB2-A200	150
C4	37–45 (50–60)	aR-160 (30) aR-200 (37)	aR-200 (30) aR-250 (37)	NZMB2-A250	250

Table 8.19 200–240 V, Enclosure Sizes A, B, and C

Enclosure	Power [kW (hp)]	Recommended fuse size	Recommended maximum fuse	Recommended circuit breaker Moeller	Maximum trip level [A]
A2	1.1–4.0 (1.5–5)	gG-10 (0.37-3) gG-16 (4)	gG-25	PKZM0-25	25
A3	5.5–7.5 (7.5–10)	gG-16	gG-32	PKZM0-25	25
A4	1.1–4.0 (1.5–5)	gG-10 (0.37-3) gG-16 (4)	gG-32	PKZM0-25	25
A5	1.1–7.5 (1.5–10)	gG-10 (0.37-3) gG-16 (4-7.5)	gG-32	PKZM0-25	25
B1	11–18.5 (15–25)	gG-40	gG-80	PKZM4-63	63
B2	22–30 (30–40)	gG-50 (18.5) gG-63 (22)	gG-100	NZMB1-A100	100
B3	11–18 (15–24)	gG-40	gG-63	PKZM4-50	50
B4	22–37 (30–50)	gG-50 (18.5) gG-63 (22) gG-80 (30)	gG-125	NZMB1-A100	100
C1	37–55 (50–75)	gG-80 (30) gG-100 (37) gG-160 (45)	gG-160	NZMB2-A200	160
C2	75–90 (100–125)	aR-200 (55) aR-250 (75)	aR-250	NZMB2-A250	250
C3	45–55 (60–75)	gG-100 (37) gG-160 (45)	gG-150 (37) gG-160 (45)	NZMB2-A200	150
C4	75–90 (100–125)	aR-200 (55) aR-250 (75)	aR-250	NZMB2-A250	250

Table 8.20 380–480 V, Enclosure Sizes A, B, and C

Enclosure	Power [kW (hp)]	Recommended fuse size	Recommended maximum fuse	Recommended circuit breaker Moeller	Maximum trip level [A]
A2	1.1–4.0 (1.5–5)	gG-10	gG-25	PKZM0-25	25
A3	5.5–7.5 (7.5–10)	gG-10 (5.5) gG-16 (7.5)	gG-32	PKZM0-25	25
A5	1.1–7.5 (1.5–10)	gG-10 (0.75-5.5) gG-16 (7.5)	gG-32	PKZM0-25	25
B1	11–18 (15–24)	gG-25 (11) gG-32 (15) gG-40 (18.5)	gG-80	PKZM4-63	63
B2	22–30 (30–40)	gG-50 (22) gG-63 (30)	gG-100	NZMB1-A100	100
B3	11–18.5 (15–25)	gG-25 (11) gG-32 (15)	gG-63	PKZM4-50	50
B4	22–37 (30–50)	gG-40 (18.5) gG-50 (22) gG-63 (30)	gG-125	NZMB1-A100	100
C1	37–55 (50–75)	gG-63 (37) gG-100 (45) aR-160 (55)	gG-160 (37-45) aR-250 (55)	NZMB2-A200	160
C2	75–90 (100–125)	aR-200 (75)	aR-250	NZMB2-A250	250
C3	45–55 (60–75)	gG-63 (37) gG-100 (45)	gG-150	NZMB2-A200	150
C4	75–90 (100–125)	aR-160 (55) aR-200 (75)	aR-250	NZMB2-A250	250

8

Table 8.21 525–600 V, Enclosure Sizes A, B, and C

Enclosure	Power [kW (hp)]	Recommended fuse size	Recommended maximum fuse	Recommended circuit breaker Wilo	Maximum trip level [A]
A3	1.1 (1.5)	gG-6	gG-25	CTI25M 10-16	16
	1.5 (2)	gG-6	gG-25	CTI25M 10-16	16
	2.2 (3)	gG-6	gG-25	CTI25M 10-16	16
	3 (4)	gG-10	gG-25	CTI25M 10-16	16
	4 (5)	gG-10	gG-25	CTI25M 10-16	16
	5.5 (7.5)	gG-16	gG-25	CTI25M 10-16	16
	7.5 (10)	gG-16	gG-25	CTI25M 10-16	16
B2	11 (15)	gG-25	gG-63	–	–
	15 (20)	gG-25	gG-63	–	–
	18 (24)	gG-32	–	–	–
	22 (30)	gG-32	–	–	–
C2	30 (40)	gG-40	–	–	–
	37 (50)	gG-63	gG-80	–	–
	45 (60)	gG-63	gG-100	–	–
	55 (75)	gG-80	gG-125	–	–
	75 (100)	gG-100	gG-160	–	–
C3	37 (50)	gG-100	gG-125	–	–
	45 (60)	gG-125	gG-160	–	–

Table 8.22 525–690 V, Enclosure Sizes A, B, and C

8.8.2 UL Compliance

Recommended maximum fuse													
Power [kW (hp)]	Maximum pre-fuse size [A]	Bussmann JFHR2	Bussmann RK1	Bussmann J	Bussmann T	Bussmann CC	Bussmann CC	Bussmann CC	SIBA RK1	Littelfuse RK1	Ferraz-Shawmut CC	Ferraz-Shawmut RK1	Ferraz-Shawmut J
1.1 (1.5)	15	FWX-15	KTN-R15	JKS-15	JJN-15	FNQ-R-15	KTK-R-15	LP-CC-15	5017906-016	KLN-R15	ATM-R15	A2K-15R	HSJ15
1.5 (2)	20	FWX-20	KTN-R20	JKS-20	JJN-20	FNQ-R-20	KTK-R-20	LP-CC-20	5017906-020	KLN-R20	ATM-R20	A2K-20R	HSJ20
2.2 (3)	30 ¹⁾	FWX-30	KTN-R30	JKS-30	JJN-30	FNQ-R-30	KTK-R-30	LP-CC-30	5012406-032	KLN-R30	ATM-R30	A2K-30R	HSJ30
3.0 (4)	35	FWX-35	KTN-R35	JKS-35	JJN-35	–	–	–	–	KLN-R35	–	A2K-35R	HSJ35
3.7 (5)	50	FWX-50	KTN-R50	JKS-50	JJN-50	–	–	–	5014006-050	KLN-R50	–	A2K-50R	HSJ50
5.5 (7.5)	60 ²⁾	FWX-60	KTN-R60	JKS-60	JJN-60	–	–	–	5014006-063	KLN-R60	–	A2K-60R	HSJ60
7.5 (10)	80	FWX-80	KTN-R80	JKS-80	JJN-80	–	–	–	5014006-080	KLN-R80	–	A2K-80R	HSJ80
15 (20)	150	FWX-150	KTN-R150	JKS-150	JJN-150	–	–	–	2028220-150	KLN-R150	–	A2K-150R	HSJ150
22 (30)	200	FWX-200	KTN-R200	JKS-200	JJN-200	–	–	–	2028220-200	KLN-R200	–	A2K-200R	HSJ200

Table 8.23 1x200–240 V, Enclosure Sizes A, B, and C

- 1) Siba allowed up to 32 A.
- 2) Siba allowed up to 63 A.

Recommended maximum fuse													
Power [kW (hp)]	Maximum pre-fuse size [A]	Bussmann JFHR2	Bussmann RK1	Bussmann J	Bussmann T	Bussmann CC	Bussmann CC	Bussmann CC	SIBA RK1	Littelfuse RK1	Ferraz-Shawmut CC	Ferraz-Shawmut RK1	Ferraz-Shawmut J
7.5 (10)	60	FWH-60	KTS-R60	JKS-60	JJS-60	–	–	–	5014006-063	KLS-R60	–	A6K-60R	HSJ60
11 (15)	80	FWH-80	KTS-R80	JKS-80	JJS-80	–	–	–	2028220-100	KLS-R80	–	A6K-80R	HSJ80
22 (30)	150	FWH-150	KTS-R150	JKS-150	JJS-150	–	–	–	2028220-160	KLS-R150	–	A6K-150R	HSJ150
37 (50)	200	FWH-200	KTS-R200	JKS-200	JJS-200	–	–	–	2028220-200	KLS-200	–	A6K-200R	HSJ200

Table 8.24 1x380–500 V, Enclosure Sizes B and C

- KTS-fuses from Bussmann may substitute KTN for 240 V frequency converters.
- FWH-fuses from Bussmann may substitute FWX for 240 V frequency converters.
- JJS-fuses from Bussmann may substitute JJN for 240 V frequency converters.
- KLSR fuses from Littelfuse may substitute KLNLR fuses for 240 V frequency converters.
- A6KR fuses from Ferraz-Shawmut may substitute A2KR for 240 V frequency converters.

Power [kW (hp)]	Recommended maximum fuse					
	Bussmann Type RK1 ¹⁾	Bussmann Type J	Bussmann Type T	Bussmann Type CC	Bussmann	Bussmann Type CC
0.25–0.37 (0.34–0.5)	KTN-R-05	JKS-05	JJN-05	FNQ-R-5	KTK-R-5	LP-CC-5
0.55–1.1 (0.75–1.5)	KTN-R-10	JKS-10	JJN-10	FNQ-R-10	KTK-R-10	LP-CC-10
1.5 (2)	KTN-R-15	JKS-15	JJN-15	FNQ-R-15	KTK-R-15	LP-CC-15
2.2 (3)	KTN-R-20	JKS-20	JJN-20	FNQ-R-20	KTK-R-20	LP-CC-20
3.0 (4)	KTN-R-25	JKS-25	JJN-25	FNQ-R-25	KTK-R-25	LP-CC-25
3.7 (5)	KTN-R-30	JKS-30	JJN-30	FNQ-R-30	KTK-R-30	LP-CC-30
5.5–7.5 (7.5–10)	KTN-R-50	JKS-50	JJN-50	–	–	–
11 (15)	KTN-R-60	JKS-60	JJN-60	–	–	–
15 (20)	KTN-R-80	JKS-80	JJN-80	–	–	–
18.5–22 (25–30)	KTN-R-125	JKS-125	JJN-125	–	–	–
30 (40)	KTN-R-150	JKS-150	JJN-150	–	–	–
37 (50)	KTN-R-200	JKS-200	JJN-200	–	–	–
45 (60)	KTN-R-250	JKS-250	JJN-250	–	–	–

Table 8.25 3x200–240 V, Enclosure Sizes A, B, and C

8

Power [kW (hp)]	Recommended maximum fuse							
	SIBA Type RK1	Littelfuse Type RK1	Ferraz- Shawmut Type CC	Ferraz- Shawmut Type RK1 ²⁾	Bussmann Type JFHR2 ³⁾	Littelfuse JFHR2	Ferraz- Shawmut JFHR2 ⁴⁾	Ferraz- Shawmut J
0.25–0.37 (0.34–0.5)	5017906-005	KLN-R-05	ATM-R-05	A2K-05-R	FWX-5	–	–	HSJ-6
0.55–1.1 (0.75–1.5)	5017906-010	KLN-R-10	ATM-R-10	A2K-10-R	FWX-10	–	–	HSJ-10
1.5 (2)	5017906-016	KLN-R-15	ATM-R-15	A2K-15-R	FWX-15	–	–	HSJ-15
2.2 (3)	5017906-020	KLN-R-20	ATM-R-20	A2K-20-R	FWX-20	–	–	HSJ-20
3.0 (4)	5017906-025	KLN-R-25	ATM-R-25	A2K-25-R	FWX-25	–	–	HSJ-25
3.7 (5)	5012406-032	KLN-R-30	ATM-R-30	A2K-30-R	FWX-30	–	–	HSJ-30
5.5–7.5 (7.5–10)	5014006-050	KLN-R-50	–	A2K-50-R	FWX-50	–	–	HSJ-50
11 (15)	5014006-063	KLN-R-60	–	A2K-60-R	FWX-60	–	–	HSJ-60
15 (20)	5014006-080	KLN-R-80	–	A2K-80-R	FWX-80	–	–	HSJ-80
18.5–22 (25–30)	2028220-125	KLN-R-125	–	A2K-125-R	FWX-125	–	–	HSJ-125
30 (40)	2028220-150	KLN-R-150	–	A2K-150-R	FWX-150	L25S-150	A25X-150	HSJ-150
37 (50)	2028220-200	KLN-R-200	–	A2K-200-R	FWX-200	L25S-200	A25X-200	HSJ-200
45 (60)	2028220-250	KLN-R-250	–	A2K-250-R	FWX-250	L25S-250	A25X-250	HSJ-250

Table 8.26 3x200–240 V, Enclosure Sizes A, B, and C

- 1) KTS-fuses from Bussmann may substitute KTN for 240 V frequency converters.
- 2) A6KR fuses from Ferraz-Shawmut may substitute A2KR for 240 V frequency converters.
- 3) FWH-fuses from Bussmann may substitute FWX for 240 V frequency converters.
- 4) A50X fuses from Ferraz-Shawmut may substitute A25X for 240 V frequency converters.

Power [kW (hp)]	Recommended maximum fuse					
	Bussmann Type RK1	Bussmann Type J	Bussmann Type T	Bussmann Type CC	Bussmann Type CC	Bussmann Type CC
–	KTS-R-6	JKS-6	JJS-6	FNQ-R-6	KTK-R-6	LP-CC-6
1.1–2.2 (1.5–3)	KTS-R-10	JKS-10	JJS-10	FNQ-R-10	KTK-R-10	LP-CC-10
3 (4)	KTS-R-15	JKS-15	JJS-15	FNQ-R-15	KTK-R-15	LP-CC-15
4 (5)	KTS-R-20	JKS-20	JJS-20	FNQ-R-20	KTK-R-20	LP-CC-20
5.5 (7.5)	KTS-R-25	JKS-25	JJS-25	FNQ-R-25	KTK-R-25	LP-CC-25
7.5 (10)	KTS-R-30	JKS-30	JJS-30	FNQ-R-30	KTK-R-30	LP-CC-30
11 (15)	KTS-R-40	JKS-40	JJS-40	–	–	–
15 (20)	KTS-R-50	JKS-50	JJS-50	–	–	–
22 (30)	KTS-R-60	JKS-60	JJS-60	–	–	–
30 (40)	KTS-R-80	JKS-80	JJS-80	–	–	–
37 (50)	KTS-R-100	JKS-100	JJS-100	–	–	–
45 (60)	KTS-R-125	JKS-125	JJS-125	–	–	–
55 (75)	KTS-R-150	JKS-150	JJS-150	–	–	–
75 (100)	KTS-R-200	JKS-200	JJS-200	–	–	–
90 (125)	KTS-R-250	JKS-250	JJS-250	–	–	–

Table 8.27 3x380–480 V, Enclosure Sizes A, B, and C

Power [kW (hp)]	Recommended maximum fuse							
	SIBA Type RK1	Littelfuse Type RK1	Ferraz- Shawmut Type CC	Ferraz- Shawmut Type RK1	Bussmann JFHR2	Ferraz- Shawmut J	Ferraz- Shawmut JFHR2 ¹⁾	Littelfuse JFHR2
–	5017906-006	KLS-R-6	ATM-R-6	A6K-6-R	FWH-6	HSJ-6	–	–
1.1–2.2 (1.5–3)	5017906-010	KLS-R-10	ATM-R-10	A6K-10-R	FWH-10	HSJ-10	–	–
3 (4)	5017906-016	KLS-R-15	ATM-R-15	A6K-15-R	FWH-15	HSJ-15	–	–
4 (5)	5017906-020	KLS-R-20	ATM-R-20	A6K-20-R	FWH-20	HSJ-20	–	–
5.5 (7.5)	5017906-025	KLS-R-25	ATM-R-25	A6K-25-R	FWH-25	HSJ-25	–	–
7.5 (10)	5012406-032	KLS-R-30	ATM-R-30	A6K-30-R	FWH-30	HSJ-30	–	–
11 (15)	5014006-040	KLS-R-40	–	A6K-40-R	FWH-40	HSJ-40	–	–
15 (20)	5014006-050	KLS-R-50	–	A6K-50-R	FWH-50	HSJ-50	–	–
22 (30)	5014006-063	KLS-R-60	–	A6K-60-R	FWH-60	HSJ-60	–	–
30 (40)	2028220-100	KLS-R-80	–	A6K-80-R	FWH-80	HSJ-80	–	–
37 (50)	2028220-125	KLS-R-100	–	A6K-100-R	FWH-100	HSJ-100	–	–
45 (60)	2028220-125	KLS-R-125	–	A6K-125-R	FWH-125	HSJ-125	–	–
55 (75)	2028220-160	KLS-R-150	–	A6K-150-R	FWH-150	HSJ-150	–	–
75 (100)	2028220-200	KLS-R-200	–	A6K-200-R	FWH-200	HSJ-200	A50-P-225	L50-S-225
90 (125)	2028220-250	KLS-R-250	–	A6K-250-R	FWH-250	HSJ-250	A50-P-250	L50-S-250

Table 8.28 3x380–480 V, Enclosure Sizes A, B, and C

1) Ferraz-Shawmut A50QS fuses may substitute A50P fuses.

Power [kW (hp)]	Recommended maximum fuse									
	Bussmann Type RK1	Bussman n Type J	Bussmann Type T	Bussmann Type CC	Bussman n Type CC	Bussman n Type CC	SIBA Type RK1	Littelfuse Type RK1	Ferraz-Shawmut Type RK1	Ferraz-Shawmut J
0.75–1.1 (1–1.5)	KTS-R-5	JKS-5	JJS-6	FNQ-R-5	KTK-R-5	LP-CC-5	5017906-005	KLS-R-005	A6K-5-R	HSJ-6
1.5–2.2 (2–3)	KTS-R-10	JKS-10	JJS-10	FNQ-R-10	KTK-R-10	LP-CC-10	5017906-010	KLS-R-010	A6K-10-R	HSJ-10
3 (4)	KTS-R-15	JKS-15	JJS-15	FNQ-R-15	KTK-R-15	LP-CC-15	5017906-016	KLS-R-015	A6K-15-R	HSJ-15
4 (5)	KTS-R-20	JKS-20	JJS-20	FNQ-R-20	KTK-R-20	LP-CC-20	5017906-020	KLS-R-020	A6K-20-R	HSJ-20
5.5 (7.5)	KTS-R-25	JKS-25	JJS-25	FNQ-R-25	KTK-R-25	LP-CC-25	5017906-025	KLS-R-025	A6K-25-R	HSJ-25
7.5 (10)	KTS-R-30	JKS-30	JJS-30	FNQ-R-30	KTK-R-30	LP-CC-30	5017906-030	KLS-R-030	A6K-30-R	HSJ-30
11–15 (15–20)	KTS-R-35	JKS-35	JJS-35	–	–	–	5014006-040	KLS-R-035	A6K-35-R	HSJ-35
18 (24)	KTS-R-45	JKS-45	JJS-45	–	–	–	5014006-050	KLS-R-045	A6K-45-R	HSJ-45
22 (30)	KTS-R-50	JKS-50	JJS-50	–	–	–	5014006-050	KLS-R-050	A6K-50-R	HSJ-50
30 (40)	KTS-R-60	JKS-60	JJS-60	–	–	–	5014006-063	KLS-R-060	A6K-60-R	HSJ-60
37 (50)	KTS-R-80	JKS-80	JJS-80	–	–	–	5014006-080	KLS-R-075	A6K-80-R	HSJ-80
45 (60)	KTS-R-100	JKS-100	JJS-100	–	–	–	5014006-100	KLS-R-100	A6K-100-R	HSJ-100
55 (75)	KTS-R-125	JKS-125	JJS-125	–	–	–	2028220-125	KLS-R-125	A6K-125-R	HSJ-125
75 (100)	KTS-R-150	JKS-150	JJS-150	–	–	–	2028220-150	KLS-R-150	A6K-150-R	HSJ-150
90 (125)	KTS-R-175	JKS-175	JJS-175	–	–	–	2028220-200	KLS-R-175	A6K-175-R	HSJ-175

Table 8.29 3x525–600 V, Enclosure Sizes A, B, and C

Power [kW (hp)]	Recommended maximum fuse							
	Maximum pre-fuse [A]	Bussmann E52273 RK1/JDDZ	Bussmann E4273 J/JDDZ	Bussmann E4273 T/JDDZ	SIBA E180276 RK1/JDDZ	Littelfuse E81895 RK1/JDDZ	Ferraz-Shawmut E163267/E2137 RK1/JDDZ	Ferraz-Shawmut E2137 J/HSJ
11–15 (15–20)	30	KTS-R-30	JKS-30	JJS-30	5017906-030	KLS-R-030	A6K-30-R	HST-30
22 (30)	45	KTS-R-45	JKS-45	JJS-45	5014006-050	KLS-R-045	A6K-45-R	HST-45
30 (40)	60	KTS-R-60	JKS-60	JJS-60	5014006-063	KLS-R-060	A6K-60-R	HST-60
37 (50)	80	KTS-R-80	JKS-80	JJS-80	5014006-080	KLS-R-075	A6K-80-R	HST-80
45 (60)	90	KTS-R-90	JKS-90	JJS-90	5014006-100	KLS-R-090	A6K-90-R	HST-90
55 (75)	100	KTS-R-100	JKS-100	JJS-100	5014006-100	KLS-R-100	A6K-100-R	HST-100
75 (100)	125	KTS-R-125	JKS-125	JJS-125	2028220-125	KLS-150	A6K-125-R	HST-125
90 (125)	150	KTS-R-150	JKS-150	JJS-150	2028220-150	KLS-175	A6K-150-R	HST-150

Table 8.30 3x525–690 V, Enclosure Sizes B and C

8.9 Power Ratings, Weight, and Dimensions

Enclosure size [kW (hp)]		A2		A3		A4	A5
3x525–690 V	T7	–		–		–	–
3x525–600 V	T6	–		0.75–7.5 (1–10)		–	0.75–7.5 (1–10)
3x380–480 V	T4	0.37–4.0 (0.5–5)		5.5–7.5 (7.5–10)		0.37–4.0 (0.5–5)	0.37–7.5 (0.5–10)
1x380–480 V	S4	–		–		1.1–4.0 (1.5–5)	–
3x200–240 V	T2	0.25–3.0 (0.34–4)		3.7 (0.5)		0.25–2.2 (0.34–3)	0.25–3.7 (0.34–5)
1x200–240 V	S2	–		1.1 (1.5)		1.1–2.2 (1.5–3)	1.1 (1.5)
IP		20	21	20	21	55/66	55/66
NEMA		Chassis	Type 1	Chassis	Type 1	Type 12/4X	Type 12/4X
Height [mm (in)]							
Height of backplate	A ¹⁾	268 (10.6)	375 (14.8)	268 (10.6)	375 (14.8)	390 (15.4)	420 (16.5)
Height with de-coupling plate for fieldbus cables	A	374 (14.7)	–	374 (14.7)	–	–	–
Distance between mounting holes	a	257 (10.1)	350 (13.8)	257 (10.1)	350 (13.8)	401 (15.8)	402 (15.8)
Width [mm (in)]							
Width of backplate	B	90 (3.5)	90 (3.5)	130 (5.1)	130 (5.1)	200 (7.9)	242 (9.5)
Width of backplate with 1 C option	B	130 (5.1)	130 (5.1)	170 (6.7)	170 (6.7)	–	242 (9.5)
Width of backplate with 2 C options	B	90 (3.5)	90 (3.5)	130 (5.1)	130 (5.1)	–	242 (9.5)
Distance between mounting holes	b	70 (2.8)	70 (2.8)	110 (4.3)	110 (4.3)	171 (6.7)	215 (8.5)
Depth²⁾ [mm (in)]							
Without option A/B	C	205 (8.1)	205 (8.1)	205 (8.1)	205 (8.1)	175 (6.9)	200 (7.9)
With option A/B	C	220 (8.7)	220 (8.7)	220 (8.7)	220 (8.7)	175 (6.9)	200 (7.9)
Screw holes [mm (in)]							
	c	8.0 (0.31)	8.0 (0.31)	8.0 (0.31)	8.0 (0.31)	8.25 (0.32)	8.2 (0.32)
	d	ø11 (0.43)	ø11 (0.43)	ø11 (0.43)	ø11 (0.43)	ø12 (0.47)	ø12 (0.47)
	e	ø5.5 (0.22)	ø5.5 (0.22)	ø5.5 (0.22)	ø5.5 (0.22)	ø6.5 (0.26)	ø6.5 (0.26)
	f	9 (0.35)	9 (0.35)	9 (0.35)	9 (0.35)	6 (0.24)	9 (0.35)
Maximum weight [kg (lb)]		4.9 (10.8)	5.3 (11.7)	6.6 (14.6)	7 (15.4)	9.7 (21.4)	14 (31)
1) See <i>Illustration 3.4</i> and <i>Illustration 3.5</i> for top and bottom mounting holes.							
2) Depth of enclosure varies with different options installed.							

Table 8.31 Power Ratings, Weight, and Dimensions, Enclosure Sizes A2-A5

Enclosure size [kW (hp)]		B1	B2	B3	B4	C1	C2	C3	C4
3x525–690 V	T7	–	11–30 (15–40)	–	–	–	37–90 (50–125)	–	–
3x525–600 V	T6	11–18.5 (15–25)	22–30 (30–40)	11–18.5 (15–25)	22–37 (30–50)	37–55 (50–75)	75–90 (100–125)	45–55 (60–75)	75–90 (100–125)
3x380–480 V	T4	11–18.5 (15–25)	22–30 (30–40)	11–18.5 (15–25)	22–37 (30–50)	37–55 (50–75)	75–90 (100–125)	45–55 (60–75)	75–90 (100–125)
1x380–480 V	S4	7.5 (10)	11 (15)	–	–	18 (24)	37 (50)	–	–
3x200–240 V	T2	5.5–11 (7.5–15)	15 (20)	5.5–11 (7.5–15)	15–18.5 (20–25)	18.5–30 (25–40)	37–45 (50–60)	22–30 (30–40)	37–45 (50–60)
1x200–240 V	S2	1.5–3.7 (2–5)	7.5 (10)	–	–	15 (20)	22 (30)	–	–
IP NEMA		21/55/66 Type 1/12/4X	21/55/66 Type 1/12/4X	20 Chassis	20 Chassis	21/55/66 Type 1/12/4X	21/55/66 Type 1/12/4X	20 Chassis	20 Chassis
Height [mm (in)]									
Height of backplate	A ¹⁾	480 (18.9)	650 (25.6)	399 (15.7)	520 (20.5)	680 (26.8)	770 (30.3)	550 (21.7)	660 (26)
Height with de-coupling plate for fieldbus cables	A	–	–	419 (16.5)	595 (23.4)	–	–	630 (24.8)	800 (31.5)
Distance between mounting holes	a	454 (17.9)	624 (24.6)	380 (15)	495 (19.5)	648 (25.5)	739 (29.1)	521 (20.5)	631 (24.8)
Width [mm (in)]									
Width of backplate	B	242 (9.5)	242 (9.5)	165 (6.5)	231 (9.1)	308 (12.1)	370 (14.6)	308 (12.1)	370 (14.6)
Width of backplate with 1 C option	B	242 (9.5)	242 (9.5)	205 (8.1)	231 (9.1)	308 (12.1)	370 (14.6)	308 (12.1)	370 (14.6)
Width of backplate with 2 C options	B	242 (9.5)	242 (9.5)	165 (6.5)	231 (9.1)	308 (12.1)	370 (14.6)	308 (12.1)	370 (14.6)
Distance between mounting holes	b	210 (8.3)	210 (8.3)	140 (5.5)	200 (7.9)	272 (10.7)	334 (13.1)	270 (10.6)	330 (13)
Depth²⁾[mm (in)]									
Without option A/B	C	260 (10.2)	260 (10.2)	248 (9.8)	242 (9.5)	310 (12.2)	335 (13.2)	333 (13.1)	333 (13.1)
With option A/B	C	260 (10.2)	260 (10.2)	262 (10.3)	242 (9.5)	310 (12.2)	335 (13.2)	333 (13.1)	333 (13.1)
Screw holes [mm (in)]									
	c	12 (0.47)	12 (0.47)	8 (0.32)	–	12 (0.47)	12 (0.47)	–	–
	d	∅19 (0.75)	∅19 (0.75)	12 (0.47)	–	∅19 (0.75)	∅19 (0.75)	–	–
	e	∅9 (0.35)	∅9 (0.35)	6.8 (0.27)	8.5 (0.33)	∅9 (0.35)	∅9 (0.35)	8.5 (0.33)	8.5 (0.33)
	f	9 (0.35)	9 (0.35)	7.9 (0.31)	15 (0.59)	9.8 (0.39)	9.8 (0.39)	17 (0.67)	17 (0.67)
Maximum weight [kg (lb)]		23 (51)	27 (60)	12 (26.5)	23.5 (52)	45 (99)	65 (143)	35 (77)	50 (110)
1) See <i>Illustration 3.4</i> and <i>Illustration 3.5</i> for top and bottom mounting holes.									
2) Depth of enclosure varies with different options installed.									

Table 8.32 Power Ratings, Weight, and Dimensions, Enclosure Sizes B1–B4, C1–C4

9 Appendix

9.1 Symbols, Abbreviations, and Conventions

°C	Degrees Celsius
°F	Degrees Fahrenheit
AC	Alternating current
AEO	Automatic energy optimization
AWG	American wire gauge
AMA	Automatic motor adaptation
DC	Direct current
EMC	Electro-magnetic compatibility
ETR	Electronic thermal relay
$f_{M,N}$	Nominal motor frequency
FC	Frequency converter
I_{INV}	Rated inverter output current
I_{LIM}	Current limit
$I_{M,N}$	Nominal motor current
$I_{VLT,MAX}$	Maximum output current
$I_{VLT,N}$	Rated output current supplied by the frequency converter
IP	Ingress protection
LCP	Local control panel
MCT	Motion control tool
n_s	Synchronous motor speed
$P_{M,N}$	Nominal motor power
PELV	Protective extra low voltage
PCB	Printed circuit board
PM Motor	Permanent magnet motor
PWM	Pulse width modulation
RPM	Revolutions per minute
Regen	Regenerative terminals
T_{LIM}	Torque limit
$U_{M,N}$	Nominal motor voltage

Table 9.1 Symbols and Abbreviations

Conventions

Numbered lists indicate procedures. Bullet lists indicate other information.

Italicized text indicates:

- Cross-reference.
- Link.
- Parameter name.
- Parameter group name.
- Parameter option.
- Footnote.

All dimensions in drawings are in [mm] (in).

9.2 Parameter Menu Structure

NOTICE

The availability of some parameters depends on the hardware configuration (installed options and power rating).

0-0*	Operation / Display	Torque Characteristics	1-79	Pump Start Max Time to Trip	3-9*	Digital Pot. Meter	5-31	Terminal 29 Digital Output
0-0*	Basic Settings	Overload Mode	1-8*	Stop Adjustments	3-90	Step Size	5-32	Term X30/6 Digi Out (MCB 101)
0-01	Language	Clockwise Direction	1-80	Function at Stop	3-91	Ramp Time	5-33	Term X30/7 Digi Out (MCB 101)
0-02	Motor Speed Unit	Motor Selection	1-81	Min Speed for Function at Stop [RPM]	3-92	Power Restore	5-4*	Relays
0-03	Regional Settings	Motor Construction	1-82	Min Speed for Function at Stop [Hz]	3-93	Maximum Limit	5-40	Function Relay
0-04	Operating State at Power-up	VVC+ PM/SYN RM	1-86	Trip Speed Low [RPM]	3-94	Minimum Limit	5-41	On Delay Relay
0-05	Local Mode Unit	Damping Gain	1-87	Trip Speed Low [Hz]	3-95	Ramp Delay	5-42	Off Delay Relay
0-1*	Set-up Operations	Low Speed Filter Time Const.	1-9*	Motor Temperature	4-2*	Limits / Warnings	5-5*	Pulse Input
0-10	Active Set-up	High Speed Filter Time Const.	1-90	Motor Thermal Protection	4-1*	Motor Limits	5-50	Term. 29 Low Frequency
0-11	Programming Set-up	Voltage filter time const.	1-91	Motor External Fan	4-10	Motor Speed Direction	5-51	Term. 29 High Frequency
0-12	This Set-up Linked to	Motor Data	1-93	Thermistor Source	4-11	Motor Speed Low Limit [RPM]	5-52	Term. 29 Low Ref./Feedb. Value
0-13	Readout: Linked Set-ups	Motor Power [kW]	1-94	ATEX ETR curlim. speed reduction	4-12	Motor Speed Low Limit [Hz]	5-53	Term. 29 High Ref./Feedb. Value
0-14	Readout: Prog. Set-ups / Channel	Motor Voltage [HP]	1-98	ATEX ETR interpol. points freq.	4-13	Motor Speed High Limit [RPM]	5-54	Pulse Filter Time Constant #29
0-2*	LCP Display	Motor Voltage	1-99	ATEX ETR interpol. points current	4-14	Motor Speed High Limit [Hz]	5-55	Term. 33 Low Frequency
0-20	Display Line 1.1 Small	Motor Frequency	2-**	Brakes	4-16	Torque Limit Motor Mode	5-56	Term. 33 High Frequency
0-21	Display Line 1.2 Small	Motor Current	2-0*	DC Brake	4-17	Torque Limit Generator Mode	5-57	Term. 33 Low Ref./Feedb. Value
0-22	Display Line 1.3 Small	Motor Nominal Speed	2-00	DC Hold/Preheat Current	4-18	Current Limit	5-58	Term. 33 High Ref./Feedb. Value
0-23	Display Line 2 Large	Motor Cont. Rated Torque	2-01	DC Brake Current	4-19	Max Output Frequency	5-59	Pulse Filter Time Constant #33
0-24	Display Line 3 Large	Motor Rotation Check	2-02	DC Braking Time	4-5*	Adj. Warnings	5-6*	Pulse Output
0-25	My Personal Menu	Automatic Motor Adaptation (AMA)	2-03	DC Brake Cut In Speed [RPM]	4-50	Warning Current Low	5-60	Terminal 27 Pulse Output Variable
0-3*	LCP Custom Readout	Adv. Motor Data	2-04	DC Brake Cut In Speed [Hz]	4-51	Warning Current High	5-62	Pulse Output Max Freq #27
0-30	Custom Readout Unit	Stator Resistance (Rs)	2-06	Parking Current	4-52	Warning Speed Low	5-63	Terminal 29 Pulse Output Variable
0-31	Custom Readout Min Value	Rotor Resistance (Rr)	2-07	Parking Time	4-53	Warning Speed High	5-65	Pulse Output Max Freq #29
0-32	Custom Readout Max Value	Stator Leakage Reactance (X1)	2-1*	Brake Energy Funct.	4-54	Warning Reference Low	5-66	Terminal X30/6 Pulse Output Variable
0-37	Display Text 1	Stator Leakage Reactance (X2)	2-10	Brake Function	4-55	Warning Reference High	5-68	Pulse Output Max Freq #X30/6
0-38	Display Text 2	Main Reactance (Xh)	2-11	Brake Resistor (ohm)	4-56	Warning Feedback Low	5-8*	I/O Options
0-39	Display Text 3	Iron Loss Resistance (Rfe)	2-12	Brake Power Limit (kW)	4-57	Warning Feedback High	5-80	AHF Cap Reconnect Delay
0-4*	LCP keypad	d-axis Inductance (Ld)	2-13	Brake Power Monitoring	4-58	Missing Motor Phase Function	5-9*	Bus Controlled
0-40	[Hand on] Key on LCP	q-axis Inductance (Lq)	2-15	Brake Check	4-6*	Speed Bypass	5-90	Digital & Relay Bus Control
0-41	[Off] Key on LCP	Motor Poles	2-16	AC brake Max. Current	4-60	Bypass Speed From [RPM]	5-93	Pulse Out #27 Bus Control
0-43	[Auto on] Key on LCP	Back EMF at 1000 RPM	2-17	Over-voltage Control	4-61	Bypass Speed From [Hz]	5-94	Pulse Out #27 Timeout Preset
0-44	[Reset] Key on LCP	d-axis Inductance Sat. (LdSat)	3-**	Reference / Ramps	4-62	Bypass Speed To [RPM]	5-95	Pulse Out #29 Bus Control
0-44	[Off/Reset] Key on LCP	q-axis Inductance Sat. (LqSat)	3-0*	Reference Limits	4-63	Bypass Speed To [Hz]	5-96	Pulse Out #29 Timeout Preset
0-45	[Drive Bypass] Key on LCP	Position Detection Gain	3-02	Minimum Reference	4-64	Semi-Auto Bypass Set-up	5-97	Pulse Out #X30/6 Bus Control
0-5*	Copy/Save	Torque Calibration	3-03	Maximum Reference	5-**	Digital In/Out	6-**	Analog In/Out
0-50	LCP Copy	Inductance Sat. Point	3-04	Reference Function	5-0*	Digital I/O mode	6-0*	Analog I/O Mode
0-51	Set-up Copy	Motor Magnetisation at Zero Speed	3-1*	References	5-00	Digital I/O Mode	6-00	Live Zero Timeout Time
0-6*	Password	Min Speed Normal Magnetising [RPM]	3-10	Preset Reference	5-01	Terminal 27 Mode	6-01	Live Zero Timeout Function
0-60	Main Menu Password	Min Speed Normal Magnetising [Hz]	3-11	Jog Speed [Hz]	5-02	Terminal 29 Mode	6-1*	Analog Input 53
0-61	Access to Main Menu w/o Password	V/f Characteristic - V	3-13	Preset Relative Reference	5-1*	Digital Inputs	6-10	Terminal 53 Low Voltage
0-65	Personal Menu Password	V/f Characteristic - f	3-14	Reference 1 Source	5-10	Terminal 18 Digital Input	6-11	Terminal 53 High Voltage
0-66	Access to Personal Menu w/o Password	Flying Start Test Pulses Current	3-15	Reference 2 Source	5-11	Terminal 19 Digital Input	6-12	Terminal 53 Low Current
0-67	Bus Password Access	Flying Start Test Pulses Frequency	3-16	Reference 3 Source	5-12	Terminal 29 Digital Input	6-13	Terminal 53 High Current
0-7*	Clock Settings	Load Depen. Setting	3-17	Jog Speed [RPM]	5-14	Terminal 32 Digital Input	6-14	Terminal 53 Low Ref./Feedb. Value
0-70	Date and Time	Low Speed Load Compensation	3-4*	Ramp 1	5-15	Terminal 33 Digital Input	6-15	Terminal 53 High Ref./Feedb. Value
0-71	Date Format	High Speed Load Compensation	3-41	Ramp 1 Ramp Up Time	5-16	Terminal X30/2 Digital Input	6-16	Terminal 53 Filter Time Constant
0-72	Time Format	Slip Compensation	3-42	Ramp 1 Ramp Down Time	5-17	Terminal X30/4 Digital Input	6-17	Terminal 53 Live Zero
0-74	DST/Summertime	Slip Compensation Time Constant	3-5*	Ramp 2	5-18	Terminal 37 Digital Input	6-2*	Analog Input 54
0-76	DST/Summertime Start	Resonance Damping	3-51	Ramp 2 Ramp Up Time	5-19	Terminal X46/1 Digital Input	6-20	Terminal 54 Low Voltage
0-77	DST/Summertime End	Min. Current at Low Speed	3-52	Ramp 2 Ramp Down Time	5-20	Terminal X46/3 Digital Input	6-21	Terminal 54 High Voltage
0-79	Clock Fault	Start Adjustments	3-8*	Other Ramps	5-21	Terminal X46/5 Digital Input	6-22	Terminal 54 Low Current
0-81	Working Days	PM Start Mode	3-80	Jog Ramp Time	5-22	Terminal X46/7 Digital Input	6-23	Terminal 54 High Current
0-82	Additional Working Days	Start Delay	3-81	Quick Stop Ramp Time	5-23	Terminal X46/9 Digital Input	6-24	Terminal 54 Low Ref./Feedb. Value
0-83	Additional Non-Working Days	Start Function	3-84	Initial Ramp Time	5-24	Terminal X46/11 Digital Input	6-25	Terminal 54 High Ref./Feedb. Value
0-89	Date and Time Readout	Flying Start	3-85	Check Valve Ramp Time	5-25	Terminal X46/13 Digital Input	6-26	Terminal 54 Filter Time Constant
1-0*	Load and Motor	Compressor Start Max Speed [RPM]	3-86	Check Valve Ramp End Speed [RPM]	5-26	Terminal 27 Digital Output	6-3*	Analog Input X30/11
1-0*	General Settings	Compressor Start Max Speed [Hz]	3-87	Check Valve Ramp End Speed [Hz]	5-3*	Digital Outputs	6-30	Terminal X30/11 Low Voltage
1-00	Configuration Mode		3-88	Final Ramp Time	5-30			
1-01	Motor Control Principle							



6-31	Terminal X30/11 High Voltage	8-37	Maximum Inter-Char Delay	10-0*	CAN Fieldbus	12-34	CIP Product Code	14-0*	Special Functions
6-34	Term. X30/11 Low Ref./Feedb. Value	8-4*	FC MC protocol set	10-0*	Common Settings	12-35	EDS Parameter	14-0*	Inverter Switching
6-35	Term. X30/11 High Ref./Feedb. Value	8-40	Telegram Selection	10-00	CAN Protocol	12-37	COS Inhibit Timer	14-00	Switching Pattern
6-36	Term. X30/11 Filter Time Constant	8-42	PCD Write Configuration	10-01	CAN Rate Select	12-38	COS Filter	14-01	Switching Frequency
6-37	Term. X30/11 Live Zero	8-43	PCD Read Configuration	10-02	MAC ID	12-38	COS Filter	14-03	Overmodulation
6-4*	Analog Input X30/12	8-5*	Digital/Bus	10-02	MAC ID	12-4*	Modbus TCP	14-04	PWM Random
6-40	Terminal X30/12 Low Voltage	8-50	Coasting Select	10-05	Readout Transmit Error Counter	12-40	Status Parameter	14-0*	Mains On/Off
6-41	Terminal X30/12 High Voltage	8-50	Quick Stop Select	10-06	Readout Receive Error Counter	12-41	Slave Message Count	14-1*	Mains Failure
6-44	Term. X30/12 Low Ref./Feedb. Value	8-51	DC Brake Select	10-07	Readout Bus Off Counter	12-42	Slave Exception Message Count	14-10	Mains Voltage at Mains Fault
6-45	Term. X30/12 High Ref./Feedb. Value	8-52	Start Select	10-1*	DeviceNet	12-8*	Other Ethernet Services	14-11	Function at Mains Imbalance
6-46	Term. X30/12 Filter Time Constant	8-53	Reversing Select	10-10	Process Data Type Selection	12-80	FTP Server	14-16	Reset Functions
6-47	Term. X30/12 Live Zero	8-54	Set-up Select	10-11	Process Data Config Write	12-81	HTTP Server	14-20	Reset Mode
6-5*	Analog Output 42	8-55	Preset Reference Select	10-12	Process Data Config Read	12-82	SMTP Service	14-21	Automatic Restart Time
6-50	Terminal 42 Output	8-56	FC Port Diagnostics	10-13	Warning Parameter	12-83	SNMP Agent	14-22	Operation Mode
6-51	Terminal 42 Output Min Scale	8-80	Bus Message Count	10-14	Net Reference	12-84	Address Conflict Detection	14-25	Trip Delay at Torque Limit
6-52	Terminal 42 Output Max Scale	8-81	Bus Error Count	10-15	Net Control	12-85	ACD Last Conflict	14-26	Trip Delay at Inverter Fault
6-53	Terminal 42 Output Bus Control	8-82	Slave Message Rcvd	10-20*	COS Filters	12-89	Transparent Socket Channel Port	14-28	Production Settings
6-54	Terminal 42 Output Timeout Preset	8-83	Slave Error Count	10-20	COS Filter 1	12-90	Advanced Ethernet Services	14-29	Service Code
6-55	Terminal 42 Output Filter	8-83	Slave Error Count	10-21	COS Filter 2	12-91	Cable Diagnostic	14-3*	Current Limit Ctrl.
6-6*	Analog Output X30/8	8-94	Bus Feedback 1	10-22	COS Filter 3	12-91	MDI-X	14-30	Current Lim Ctrl, Proportional Gain
6-60	Terminal X30/8 Output	8-95	Bus Feedback 2	10-3*	Parameter Access	12-92	IGMP Snooping	14-31	Current Lim Ctrl, Integration Time
6-61	Terminal X30/8 Min. Scale	8-96	Bus Feedback 3	10-30	Array Index	12-93	Cable Error Length	14-32	Current Lim Ctrl, Filter Time
6-62	Terminal X30/8 Max. Scale	8-96	Bus Feedback 3	10-31	Store Data Values	12-94	Broadcast Storm Protection	14-40	VT Level
6-63	Terminal X30/8 Output Bus Control	9-00	Setpoint	10-32	Deviacenet Revision	12-96	Port Config	14-4*	Energy Optimising
6-64	Terminal X30/8 Output Timeout Preset	9-07	Actual Value	10-33	Store Always	12-97	QoS Priority	14-41	AEQ Minimum Magnetsation
6-7*	Analog Output X45/1	9-15	PCD Write Configuration	10-34	DeviceNet Product Code	12-98	Interface Counters	14-42	Minimum AEO Frequency
6-70	Terminal X45/1 Output	9-16	PCD Read Configuration	10-39	Deviacenet F Parameters	12-99	Media Counters	14-43	Motor Cosphi
6-71	Terminal X45/1 Min. Scale	9-18	Node Address	12-0*	Ethernet	13-0*	Smart Logic	14-4*	Environment
6-72	Terminal X45/1 Max. Scale	9-22	Telegram Selection	12-00	IP Settings	13-0*	SL Controller Mode	14-50	RFI Filter
6-73	Terminal X45/1 Bus Control	9-23	Parameters for Signals	12-01	IP Address Assignment	13-00	SL Controller Mode	14-51	DC Link Compensation
6-74	Terminal X45/1 Output Timeout Preset	9-27	Parameter Edit	12-02	IP Address	13-01	Start Event	14-52	Fan Control
6-8*	Analog Output X45/3	9-28	Process Control	12-02	Subnet Mask	13-02	Stop Event	14-53	Fan Monitor
6-80	Terminal X45/3 Output	9-31	Safe Address	12-03	Default Gateway	13-03	Reset SLC	14-55	Output Filter
6-81	Terminal X45/3 Min. Scale	9-44	Fault Message Counter	12-04	DHCP Server	13-1*	Comparators	14-56	Capacitance Output Filter
6-82	Terminal X45/3 Max. Scale	9-45	Fault Code	12-05	Lease Expires	13-11	Comparator Operator	14-57	Inductance Output Filter
6-83	Terminal X45/3 Bus Control	9-47	Fault Number	12-06	Name Servers	13-12	Comparator Value	14-58	Voltage Gain Filter
6-84	Terminal X45/3 Output Timeout Preset	9-52	Fault Situation Counter	12-07	Domain Name	13-1*	RS Flip Flops	14-59	Actual Number of Inverter Units
8-0*	Comm. and Options	9-53	Profibus Warning Word	12-08	Host Name	13-15	RS-FF Operand S	14-6*	Auto Derate
8-01	Control Site	9-63	Actual Baud Rate	12-09	Physical Address	13-16	RS-FF Operand R	14-60	Function at Over Temperature
8-02	Control Source	9-64	Profile Identification	12-10	Ethernet Link Parameters	13-2*	Timers	14-61	Function at Inverter Overload
8-03	Control Timeout Time	9-65	Profile Number	12-10	Link Status	13-20	SL Controller Timer	14-62	Inv. Overload Derate Current
8-04	Control Timeout Function	9-67	Status Word 1	12-11	Link Duration	13-4*	Logic Rules	14-8*	Options
8-05	End-of/Timeout Function	9-68	Status Word 1	12-12	Auto Negotiation	13-40	Logic Rule Boolean 1	14-9*	Option Supplied by External 24VDC
8-06	Reset Control Timeout	9-70	Programming Set-up	12-13	Link Speed	13-41	Logic Rule Operator 1	14-90	Fault Settings
8-07	Diagnosis Trigger	9-71	Profibus Save Data Values	12-14	Link Duplex	13-42	Logic Rule Boolean 2	15-0*	Drive Information
8-08	Readout Filtering	9-72	ProfibusDriveReset	12-18	Supervisor MAC	13-43	Logic Rule Operator 2	15-0*	Operating Data
8-1*	Control Settings	9-75	DO Identification	12-19	Supervisor IP Addr.	13-44	Logic Rule Boolean 3	15-00	Operating hours
8-10	Control Profile	9-80	Defined Parameters (1)	12-2*	Process Data	13-5*	States	15-01	Running Hours
8-13	Configurable Status Word STW	9-81	Defined Parameters (2)	12-20	Control Instance	13-51	SL Controller Event	15-02	kWh Counter
8-14	Configurable Control Word CTW	9-82	Defined Parameters (3)	12-21	Process Data Config Write	13-52	SL Controller Action	15-03	Power Up's
8-17	Configurable Alarm and Warningword	9-83	Defined Parameters (4)	12-22	Process Data Config Read	13-9*	User Defined Alerts	15-04	Over Temp's
8-3*	FC Port Settings	9-84	Defined Parameters (5)	12-27	Primary Master	13-90	Alert Trigger	15-05	Over Volt's
8-30	Protocol	9-85	Defined Parameters (6)	12-28	Store Data Values	13-91	Alert Action	15-06	Reset kWh Counter
8-31	Address	9-90	Changed Parameters (1)	12-29	Store Always	13-92	Alert Text	15-07	Reset Running Hours Counter
8-32	Baud Rate	9-91	Changed Parameters (2)	12-30	Warning Parameter	13-97	User Defined Readouts	15-08	Number of Starts
8-33	Parity / Stop Bits	9-92	Changed Parameters (3)	12-31	Net Reference	13-98	Alert Warning Word	15-1*	Data Log Settings
8-35	Minimum Response Delay	9-93	Changed Parameters (4)	12-32	Net Control	13-99	Alert Status Word	15-10	Logging Source
8-36	Max Response Delay	9-94	Changed Parameters (5)	12-33	CIP Revision				
		9-99	Profibus Revision Counter						

15-11	Logging Interval	16-01	Reference [Unit]	20-21	Setpoint 1	21-40	Ext. 2 Normal/Inverse Control
15-12	Trigger Event	16-02	Reference [%]	20-22	Setpoint 2	21-41	Ext. 2 Proportional Gain
15-13	Logging Mode	16-03	Status Word	20-23	Setpoint 3	21-42	Ext. 2 Integral Time
15-14	Samples Before Trigger	16-05	Main Actual Value [%]	20-6*	Sensorless	21-43	Ext. 2 Differentiation Time
15-2*	Historic Log	16-09	Custom Readout	20-60	Sensorless Unit	21-44	Ext. 2 Dif. Gain Limit
15-20	Historic Log: Event	16-1*	Motor Status	20-69	Sensorless Information	21-5*	Ext. CL 3 Ref/Fb
15-21	Historic Log: Value	16-10	Power [kW]	20-7*	PID Autotuning	21-50	Ext. 3 Ref./Feedback Unit
15-22	Historic Log: Time	16-11	Power [hp]	20-70	Closed Loop Type	21-51	Ext. 3 Minimum Reference
15-23	Historic log: Date and Time	16-12	Motor Voltage	20-71	PID Performance	21-52	Ext. 3 Maximum Reference
15-3*	Alarm Log	16-13	Frequency	20-72	PID Output Change	21-53	Ext. 3 Reference Source
15-30	Alarm Log: Error Code	16-14	Motor current	20-73	Minimum Feedback Level	21-54	Ext. 3 Feedback Source
15-31	Alarm Log: Value	16-15	Frequency [%]	20-74	Maximum Feedback Level	21-55	Ext. 3 Setpoint
15-32	Alarm Log: Time	16-16	Torque [Nm]	20-79	PID Autotuning	21-57	Ext. 3 Reference [Unit]
15-33	Alarm Log: Date and Time	16-17	Speed [RPM]	20-8*	PID Basic Settings	21-58	Ext. 3 Feedback [Unit]
15-34	Alarm Log: Setpoint	16-18	Motor Thermal	20-81	PID Normal/ Inverse Control	21-59	Ext. 3 Output [%]
15-35	Alarm Log: Feedback	16-20	Motor Angle	20-82	PID Start Speed [RPM]	21-6*	Ext. CL 3 PID
15-36	Alarm Log: Current Demand	16-22	Torque [%]	20-83	PID Start Speed [Hz]	21-60	Ext. 3 Normal/Inverse Control
15-37	Alarm Log: Process Ctrl Unit	16-23	Motor Shaft Power [kW]	20-84	On Reference Bandwidth	21-61	Ext. 3 Proportional Gain
15-4*	Drive Identification	16-24	Calibrated Stator Resistance	20-9*	PID Antirunner	21-62	Ext. 3 Integral Time
15-40	FC Type	16-26	Power Filtered [kW]	20-91	PID Anti Windup	21-63	Ext. 3 Differentiation Time
15-41	Power Section	16-27	Power Filtered [hp]	20-93	PID Proportional Gain	21-64	Ext. 3 Dif. Gain Limit
15-42	Voltage	16-3*	Drive Status	20-94	PID Integral Time	22-*	Appl. Functions
15-43	Software Version	16-30	DC Link Voltage	20-95	PID Differentiation Time	22-0*	Miscellaneous
15-44	Ordered Typecode String	16-31	System Temp.	20-96	PID Diff. Gain Limit	22-00	External Interlock Delay
15-45	Actual Typecode String	16-32	Brake Energy /s	21-*	Ext. Closed Loop	22-01	Power Filter Time
15-46	Frequency Converter Ordering	16-33	Brake Energy Average	21-0*	Ext. CL Autotuning	22-2*	No-Flow Detection
15-47	Power Card Ordering No	16-34	Heatsink Temp.	21-00	Closed Loop Type	22-20	Low Power Auto Set-up
15-48	LCP ID No	16-35	Inverter Thermal	21-01	PID Performance	22-21	Low Power Detection
15-49	SW ID Control Card	16-36	Inv. Nom. Current	21-02	PID Output Change	22-22	Low Speed Detection
15-50	SW ID Power Card	16-37	Inv. Max. Current	21-03	Minimum Feedback Level	22-23	No-Flow Function
15-51	Frequency Converter Serial Number	16-38	SL Controller State	21-04	Maximum Feedback Level	22-24	No-Flow Delay
15-53	Power Card Serial Number	16-39	Control Card Temp.	21-09	PID Auto Tuning	22-26	Dry Pump Function
15-54	Config File Name	16-40	Logging Buffer Full	21-1*	Ext. CL 1 Ref/Fb.	22-27	Dry Pump Delay
15-58	SmartStart Filename	16-49	Current Fault Source	21-10	Ext. 1 Ref./Feedback Unit	22-28	No-Flow Low Speed [RPM]
15-59	Filename	16-5*	Ref. & Feeds.	21-11	Ext. 1 Minimum Reference	22-29	No-Flow Low Speed [Hz]
15-6*	Option Ident	16-50	External Reference	21-12	Ext. 1 Maximum Reference	22-3*	No-Flow Power Tuning
15-60	Option Mounted	16-52	Feedback[Unit]	21-13	Ext. 1 Reference Source	22-30	No-Flow Power
15-61	Option SW Version	16-53	Digi Pot Reference	21-14	Ext. 1 Feedback Source	22-31	Power Correction Factor
15-62	Option Ordering No	16-54	Feedback 1 [Unit]	21-15	Ext. 1 Setpoint	22-32	Low Speed [RPM]
15-63	Option Serial No	16-55	Feedback 2 [Unit]	21-17	Ext. 1 Reference [Unit]	22-33	Low Speed [Hz]
15-70	Option in Slot A	16-56	Feedback 3 [Unit]	21-18	Ext. 1 Feedback [Unit]	22-34	Low Speed Power [kW]
15-71	Slot A Option SW Version	16-59	Adjusted Setpoint	21-19	Ext. 1 Output [%]	22-35	Low Speed Power [HP]
15-72	Option in Slot B	16-6*	Inputs & Outputs	21-2*	Ext. CL 1 PID	22-36	High Speed [RPM]
15-73	Slot B Option SW Version	16-60	Digital Input	21-20	Ext. 1 Normal/Inverse Control	22-37	High Speed [Hz]
15-74	Option in Slot C0/E0	16-61	Terminal 53 Switch Setting	21-21	Ext. 1 Proportional Gain	22-38	High Speed Power [kW]
15-75	Slot C0/E0 Option SW Version	16-62	Terminal 54 Switch Setting	21-22	Ext. 1 Integral Time	22-39	High Speed Power [HP]
15-76	Option in Slot C1/E1	16-63	Analog Input 53	21-23	Ext. 1 Differentiation Time	22-4*	Sleep Mode
15-8*	Operating Data II	16-64	Analog Input 54	21-24	Ext. 1 Dif. Gain Limit	22-40	Minimum Run Time
15-80	Fan Running Hours	16-65	Analog Output 42 [mA]	21-3*	Ext. CL 2 Ref/Fb.	22-41	Minimum Sleep Time
15-81	Preset Fan Running Hours	16-66	Digital Output [bin]	21-30	Ext. 2 Ref./Feedback Unit	22-42	Wake-up Speed [RPM]
15-9*	Parameter Info	16-67	Pulse Input #29 [Hz]	21-31	Ext. 2 Minimum Reference	22-43	Wake-up Speed [Hz]
15-92	Defined Parameters	16-68	Pulse Input #33 [Hz]	21-32	Ext. 2 Maximum Reference	22-44	Wake-up Ref./FB Difference
15-93	Modified Parameters	16-69	Pulse Output #27 [Hz]	21-33	Ext. 2 Reference Source	22-45	Setpoint Boost
15-98	Drive Identification	16-70	Pulse Output #29 [Hz]	21-34	Ext. 2 Feedback Source	22-46	Maximum Boost Time
15-99	Parameter Metadata	16-71	Relay Output [bin]	21-35	Ext. 2 Setpoint	22-5*	End of Curve
16-0*	General Status	16-72	Counter A	21-37	Ext. 2 Reference [Unit]	22-50	End of Curve Function
16-00	Control Word	16-73	Counter B	21-38	Ext. 2 Feedback [Unit]	22-51	End of Curve Delay
		16-75	Analog In X30/11	21-39	Ext. 2 Output [%]	22-6*	Broken Belt Detection
				20-20	Feedback Function	22-60	Broken Belt Function



22-61	Broken Belt Torque	24-11	Drive Bypass Delay Time	26-14	Term. X42/1 Low Ref./Feedb. Value	27-3*	Staging Speed	29-15	Derag Off Delay
22-62	Broken Belt Delay	25-5** Cascade Controller		26-15	Term. X42/1 High Ref./Feedb. Value	27-30	Auto Tune Staging Speeds	29-2** Derag Power Tuning	
22-7** Short Cycle Protection		25-0* System Settings		26-16	Term. X42/1 Filter Time Constant	27-31	Stage On Speed [RPM]	29-20	Derag Power [kW]
22-75	Short Cycle Protection	25-00	Cascade Controller	26-17	Term. X42/1 Live Zero	27-32	Stage On Speed [Hz]	29-21	Derag Power [HP]
22-76	Interval between Starts	25-02	Motor Start	26-2* Analog Input X42/3		27-33	Stage Off Speed [RPM]	29-22	Derag Power Factor
22-77	Minimum Run Time	25-04	Pump Cycling	26-20	Terminal X42/3 Low Voltage	27-34	Stage Off Speed [Hz]	29-23	Derag Power Delay
22-78	Minimum Run Time Override	25-05	Fixed Lead Pump	26-21	Terminal X42/3 High Voltage	27-4* Staging Settings		29-24	Low Speed [RPM]
22-79	Minimum Run Time Override Value	25-06	Number of Pumps	26-22	Terminal X42/3 Low Ref./Feedb. Value	27-40	Auto Tune Staging Settings	29-25	Low Speed [Hz]
22-8* Flow Compensation		25-2* Bandwidth Settings		26-25	Term. X42/3 High Ref./Feedb. Value	27-41	Ramp Down Delay	29-26	Low Speed Power [kW]
22-80	Flow Compensation	25-20	Staging Bandwidth	26-26	Term. X42/3 Filter Time Constant	27-42	Ramp Up Delay	29-27	Low Speed Power [HP]
22-81	Square-linear Curve Approximation	25-21	Override Bandwidth	26-27	Term. X42/3 Live Zero	27-43	Staging Threshold	29-28	High Speed [RPM]
22-82	Work Point Calculation	25-22	Fixed Speed Bandwidth	26-3* Analog Input X42/5		27-44	Destaging Threshold	29-29	High Speed [Hz]
22-83	Speed at No-Flow [RPM]	25-23	SBW Staging Delay	26-30	Terminal X42/5 Low Voltage	27-45	Staging Speed [RPM]	29-30	High Speed Power [kW]
22-84	Speed at No-Flow [Hz]	25-24	SBW Destaging Delay	26-31	Terminal X42/5 High Voltage	27-46	Staging Speed [Hz]	29-31	High Speed Power [HP]
22-85	Speed at Design Point [RPM]	25-25	OBW Time	26-34	Term. X42/5 Low Ref./Feedb. Value	27-47	Destaging Speed [RPM]	29-32	Derag On Ref Bandwidth
22-86	Speed at Design Point [Hz]	25-26	Destage At No-Flow	26-35	Term. X42/5 High Ref./Feedb. Value	27-48	Destaging Speed [Hz]	29-33	Power Derag Limit
22-87	Pressure at No-Flow Speed	25-27	Stage Function	26-36	Term. X42/5 Filter Time Constant	27-49	Staging Principle	29-34	Consecutive Derag Interval
22-88	Pressure at Rated Speed	25-28	Stage Function Time	26-37	Term. X42/5 Live Zero	27-5* Alternate Settings		29-35	Derag at Locked Rotor
22-89	Flow at Design Point	25-29	Destage Function	26-4* Analog Out X42/7		27-50	Automatic Alternation	29-4* Pre/Post Lube	
22-90	Flow at Rated Speed	25-30	Destage Function Time	26-40	Terminal X42/7 Output	27-51	Alternation Event	29-40	Pre/Post Lube Function
23-3** Time-based Functions		25-4* Staging Settings		26-41	Terminal X42/7 Min. Scale	27-52	Alternation Time Interval	29-41	Pre Lube Time
23-0* ON Time		25-40	Ramp Down Delay	26-42	Terminal X42/7 Max. Scale	27-53	Alternation Timer Value	29-42	Post Lube Time
23-01	ON Action	25-41	Ramp Up Delay	26-43	Terminal X42/7 Bus Control	27-54	Alternation At Time of Day	29-5* Flow Confirmation	
23-02	OFF Time	25-42	Staging Threshold	26-44	Terminal X42/7 Timeout Preset	27-55	Alternation Predefined Time	29-50	Validation Time
23-03	OFF Action	25-43	Destaging Threshold	26-5* Analog Out X42/9		27-56	Alternate Capacity is <	29-51	Verification Time
23-04	Occurrence	25-44	Staging Speed [RPM]	26-50	Terminal X42/9 Output	27-58	Run Next Pump Delay	29-52	Signal Lost Verification Time
23-1* Maintenance		25-45	Staging Speed [Hz]	26-51	Terminal X42/9 Min. Scale	27-6* Digital Inputs		29-53	Flow Confirmation Mode
23-10	Maintenance Item	25-46	Destaging Speed [RPM]	26-52	Terminal X42/9 Max. Scale	27-60	Terminal X66/1 Digital Input	29-6* Flow Meter	
23-11	Maintenance Action	25-47	Destaging Speed [Hz]	26-53	Terminal X42/9 Bus Control	27-61	Terminal X66/3 Digital Input	29-60	Flow Meter Monitor
23-12	Maintenance Time Base	25-48	Staging Principle	26-54	Terminal X42/9 Timeout Preset	27-62	Terminal X66/5 Digital Input	29-61	Flow Meter Source
23-13	Maintenance Time Interval	25-50	Lead Pump Alternation	26-6* Analog Out X42/11		27-63	Terminal X66/7 Digital Input	29-62	Flow Meter Unit
23-14	Maintenance Date and Time	25-51	Alternation Event	26-60	Terminal X42/11 Output	27-64	Terminal X66/9 Digital Input	29-63	Totalized Volume Unit
23-1* Maintenance Reset		25-52	Alternation Time Interval	26-61	Terminal X42/11 Min. Scale	27-65	Terminal X66/11 Digital Input	29-64	Actual Volume Unit
23-15	Reset Maintenance Word	25-53	Alternation Timer Value	26-62	Terminal X42/11 Max. Scale	27-66	Terminal X66/13 Digital Input	29-65	Totalized Volume
23-16	Maintenance Text	25-54	Alternation Predefined Time	26-64	Terminal X42/11 Bus Control	27-7* Connections		29-66	Actual Volume
23-5* Energy Log		25-55	Alternate if Load < 50%	27-8** Cascade CTL Option		27-70	Relay	29-67	Reset Totalized Volume
23-50	Energy Log Resolution	25-56	Staging Mode at Alternation	27-0* Control & Status		27-91	Cascade Reference	29-68	Reset Actual Volume
23-51	Period Start	25-58	Run Next Pump Delay	27-01	Pump Status	27-92	% Of Total Capacity	29-69	Flow
23-53	Energy Log	25-59	Run on Mains Delay	27-02	Manual Pump Control	27-93	Cascade Option Status	30-2** Special Features	
23-54	Reset Energy Log	25-8* Status		27-03	Current Runtime Hours	27-94	Cascade System Status	30-2* Adv. Start Adjust	
23-6* Trending		25-80	Cascade Status	27-04	Pump Total Lifetime Hours	27-95	Advanced Cascade Relay Output [bin]	30-22	Locked Rotor Detection
23-60	Trend Variable	25-81	Pump Status	27-1* Configuration		27-96	Extended Cascade Relay Output [bin]	30-5* Unit Configuration	
23-61	Continuous Bin Data	25-82	Lead Pump	27-10	Cascade Controller	29-3** Water Application Functions		30-50	Heat Sink Fan Mode
23-62	Timed Bin Data	25-83	Relay Status	27-11	Number Of Drives	29-0* Pipe Fill		30-8* Compatibility (I)	
23-63	Timed Period Start	25-84	Pump ON Time	27-12	Number Of Pumps	29-00	Pipe Fill Enable	30-81	Brake Resistor (ohm)
23-64	Timed Period Stop	25-85	Relay ON Time	27-14	Pump Capacity	29-01	Pipe Fill Speed [RPM]	31-3** Bypass Option	
23-65	Minimum Bin Value	25-86	Reset Relay Counters	27-16	Runtime Balancing	29-02	Pipe Fill Speed [Hz]	31-00	Bypass Mode
23-66	Reset Continuous Bin Data	25-9* Service		27-17	Motor Starters	29-03	Pipe Fill Time	31-01	Bypass Start Time Delay
23-67	Reset Timed Bin Data	25-90	Pump Interlock	27-18	Spin Time for Unused Pumps	29-04	Pipe Fill Rate	31-02	Bypass Trip Time Delay
23-8* Payback Counter		25-91	Manual Alternation	27-19	Reset Current Runtime Hours	29-05	Filled Setpoint	31-03	Test Mode Activation
23-80	Power Reference Factor	26-5** Analog I/O Option		27-2* Bandwidth Settings		29-06	No-Flow Disable Timer	31-10	Bypass Status Word
23-81	Energy Cost	26-00	Terminal X42/1 Mode	27-20	Normal Operating Range	29-07	Filled setpoint delay	31-11	Bypass Running Hours
23-82	Investment	26-01	Terminal X42/3 Mode	27-21	Override Limit	29-1* Deragging Function		31-19	Remote Bypass Activation
23-83	Energy Savings	26-02	Terminal X42/5 Mode	27-22	Fixed Speed Only Operating Range	29-10	Derag at Start/Stop	35-5** Sensor Input Option	
23-84	Cost Savings	26-02	Terminal X42/5 Mode	27-23	Staging Delay	29-11	Derag at Start/Stop	35-00	Temp. Input Mode
24-3** Appl. Functions 2		26-1* Analog Input X42/1		27-24	Destaging Delay	29-12	Deragging Run Time	35-00	Term. X48/4 Temperature Unit
24-1* Drive Bypass		26-10	Terminal X42/1 Low Voltage	27-25	Override Hold Time	29-13	Derag Speed [RPM]	35-01	Term. X48/4 Input Type
24-10	Drive Bypass Function	26-11	Terminal X42/1 High Voltage	27-27	Min. Speed Destage Delay	29-14	Derag Speed [Hz]	35-02	Term. X48/7 Temperature Unit

35-03	Term. X48/7 Input Type
35-04	Term. X48/10 Temperature Unit
35-05	Term. X48/10 Input Type
35-06	Temperature Sensor Alarm Function
35-1*	Temp. Input X48/4
35-14	Term. X48/4 Filter Time Constant
35-15	Term. X48/4 Temp. Monitor
35-16	Term. X48/4 Low Temp. Limit
35-17	Term. X48/4 High Temp. Limit
35-2*	Temp. Input X48/7
35-24	Term. X48/7 Filter Time Constant
35-25	Term. X48/7 Temp. Monitor
35-26	Term. X48/7 Low Temp. Limit
35-27	Term. X48/7 High Temp. Limit
35-3*	Temp. Input X48/10
35-34	Term. X48/10 Filter Time Constant
35-35	Term. X48/10 Temp. Monitor
35-36	Term. X48/10 Low Temp. Limit
35-37	Term. X48/10 High Temp. Limit
35-4*	Analog Input X48/2
35-42	Term. X48/2 Low Current
35-43	Term. X48/2 High Current
35-44	Term. X48/2 Low Ref./Feedb. Value
35-45	Term. X48/2 High Ref./Feedb. Value
35-46	Term. X48/2 Filter Time Constant
35-47	Term. X48/2 Live Zero
43-*	Unit Readouts
43-0*	Component Status
43-00	Component Temp.
43-01	Auxiliary Temp.
43-1*	Power Card Status
43-10	HS Temp. ph.U
43-11	HS Temp. ph.V
43-12	HS Temp. ph.W
43-13	PC Fan A Speed
43-14	PC Fan B Speed
43-15	PC Fan C Speed
43-2*	Fan Pow.Card Status
43-20	FPC Fan A Speed
43-21	FPC Fan B Speed
43-22	FPC Fan C Speed
43-23	FPC Fan D Speed
43-24	FPC Fan E Speed
43-25	FPC Fan F Speed

Index

A

Abbreviation..... 80

AC

 input..... 8, 19

 mains..... 8, 19

 waveform..... 8

Additional resources..... 4

Alarm log..... 26

Alarms

 Alarms..... 39

AMA

 AMA..... 37, 41, 45

 Automatic motor adaptation..... 31

Ambient conditions..... 67

Analog output..... 20, 68

Analog signal..... 40

Analog speed reference..... 34

Approvals and certifications..... 8

ASM..... 29

Auto on..... 27, 32, 37, 39

Automatic energy optimization..... 31

Auto-reset..... 25

Auxiliary equipment..... 24

B

Backplate..... 12

Brake

 Braking..... 37

Braking..... 42

Burst transient..... 15

C

Cable

 routing..... 24

 Motor cable..... 14, 18, 65

 Motor cable length..... 67

 Specifications..... 67

Circuit breaker..... 24, 71, 72, 73

Clearance requirements..... 12

Closed loop..... 22

Communication option..... 43

Conduct..... 24

Control

 characteristic..... 70

 signal..... 37

 terminal..... 27, 29, 37, 39

 wiring..... 18, 21, 24

 Local control..... 25, 27, 37

 Wiring..... 14

Control card

 Control card..... 40

 Control card performance..... 70

 Control card, 10 V DC output..... 70

 Control card, 24 V DC output..... 69

 Control card, RS485 serial communication..... 67

 USB serial communication..... 70

Convention..... 80

Cooling..... 12, 65

Cooling clearance..... 24

Cos ϕ 66, 69

Current

 level..... 68

 limit..... 48

 mode..... 68

 range..... 68

 rating..... 41

 DC current..... 8, 14, 38

 Input current..... 19

 Output current..... 38

D

DC link..... 40

Default settings..... 27

Derating..... 67

Digital output..... 69

Dimensions..... 78, 79

Discharge time..... 9

Disconnect switch..... 25

Displacement power factor..... 66

E

Efficiency..... 65, 67

EMC interference..... 18

EMC-compliant installation..... 14

Environment..... 67

Exploded view..... 6, 7

External alarm reset..... 35

External command..... 8, 39

External controllers..... 4

External interlock..... 35

F

Fault log..... 26

Feedback..... 22, 24, 33, 38, 44, 46

Floating delta..... 19

Fue..... 71

Fuse..... 14, 24, 43, 47, 71, 72, 73, 74, 75, 76, 77

G

Ground	
connection.....	24
wire.....	14
Grounding.....	24
Grounded delta.....	19
Grounding.....	18, 19, 25

H

Hand on.....	27, 37
Harmonics	
Harmonics.....	8
High altitude.....	67
High voltage.....	9, 25
Humidity.....	67

I

IEC 61800-3.....	19
Initialization.....	28
Input	
Analog input.....	20, 40, 68
Digital input.....	20, 21, 39, 41, 68
disconnect.....	19
power.....	8, 14, 18, 19, 24, 39
power wiring.....	24
signal.....	22
terminal.....	19, 22, 25, 40
voltage.....	25
Pulse input.....	69
Installation	
Check list.....	24
Installation.....	21, 23
environment.....	11
Intended use.....	4
Interference isolation.....	24
Interlock.....	35
Items supplied.....	11

J

Jumper.....	21
-------------	----

L

LCP.....	25
Leakage current.....	10, 14
Lifting.....	12
Load sharing.....	9, 51, 52, 53, 55, 56, 57, 58, 59, 60, 61, 62, 63, 64, 65
Local control panel.....	25

M

Main menu.....	26
Mains	
voltage.....	26, 38
Transient.....	8
Maintenance.....	37
Manual initialization.....	28
MCT 10.....	20, 25
Menu key.....	25, 26
Menu structure.....	26
Modbus RTU.....	23
Motor	
cable.....	14, 18
current.....	8, 26, 31, 45
data.....	29, 32, 41, 45, 48
output.....	66
power.....	14, 26, 45
rotation.....	32
speed.....	28
status.....	4
thermal protection.....	36
thermistor.....	36
wiring.....	18, 24
Output current.....	41
Output performance (U, V, W).....	66
Thermistor.....	36
Unintended motor rotation.....	10
Mounting.....	12, 24

N

Nameplate.....	11
Navigation key.....	25, 26, 28, 37

O

Open loop.....	22
Operation key.....	25
Optional equipment.....	19, 22, 25
Output	
power wiring.....	24
Overcurrent protection.....	14
Overload	
High overload.....	65, 66
Normal overload.....	50, 54, 66
torque.....	66
Overvoltage.....	38, 48, 66, 69

P

Parameter menu structure.....	81
PELV.....	36, 67, 68, 69, 70
Phase loss.....	40
PM Motor.....	29

Potential equalization.....	15	SmartStart.....	28
Potentiometer.....	34	Specifications.....	23
Power		Start-up.....	28
Input power.....	25, 47	Status display.....	37
connection.....	14	Status mode.....	37
factor.....	8, 24	STO.....	22
Power factor.....	66	see also <i>Safe Torque Off</i>	
Programming.....	21, 25, 26, 27, 40	Storage.....	11, 67
Q		Supply voltage.....	19, 20, 25, 43
Qualified personnel.....	9	Switch.....	22
Quick menu.....	26	Switching frequency.....	39
R		Symbol.....	80
Ramp-down time.....	48	SynRM.....	30
Ramp-up time.....	48	System feedback.....	4
Reference		T	
Reference.....	26, 33, 37, 38, 39	Terminal	
Remote reference.....	38	Output terminal.....	25
Speed reference.....	22, 32, 34, 37	53.....	22
Relay		54.....	22
Relay.....	21	tightening torques.....	70
1.....	69	Thermal protection.....	8
2.....	69	Thermistor	
output.....	69	Thermistor.....	19
Remote commands.....	4	Thermistor.....	41
Reset.....	25, 27, 28, 39, 41, 46	Torque	
RFI filter.....	19	Starting torque.....	66
RMS current.....	8	characteristic.....	66
RS485		limit.....	48
RS485.....	36	Transient protection.....	8
Run command.....	32	Trip	
Run permissive.....	35, 38	Trip.....	36, 39
Run/stop command.....	35	level.....	71, 72, 73
S		lock.....	39
Safe Torque Off		Troubleshooting.....	49
Safe Torque Off.....	22	True power factor.....	66
Warning.....	45	U	
Safety.....	10	UL certification.....	8
Serial communication		UL compliance.....	74
RS485.....	22	Unintended start.....	9, 37
Serial communication.....	20, 21, 22, 27, 37, 38, 39	V	
Service.....	37	Vibration.....	11
Setpoint.....	39	Voltage imbalance.....	40
Set-up.....	32	Voltage level.....	68
Shielded cable.....	18, 24	VVC+.....	29
Shock.....	11		
Short circuit.....	42		
Sleep mode.....	39		

W

Warnings

Warnings..... 39

Weight..... 78, 79

Windmilling..... 10

Wire size..... 14, 18

Wiring

Control wiring..... 18, 21

Motor wiring..... 18

Thermistor control wiring..... 19

Wiring schematic..... 16

wilo

Pioneering for You

WILO SE
Nortkirchenstraße 100
44263 Dortmund
Germany
T +49 (0)231 4102-0
F +49 (0)231 4102-7363
wilo@wilo.com
www.wilo.com

130R0820

