

Data Sheet | Item Number: 891-8995/206-402

pre-assembled connecting cable; Eca; Plug/open-ended; 5-pole; Cod. A; H05VV-F
5G 1.5 mm²; 4 m; 1,50 mm²; white

<https://www.wago.com/891-8995/206-402>

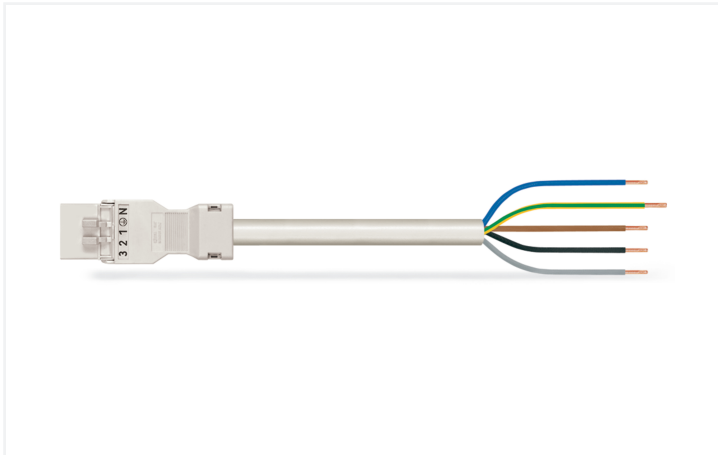

Color: ■ white

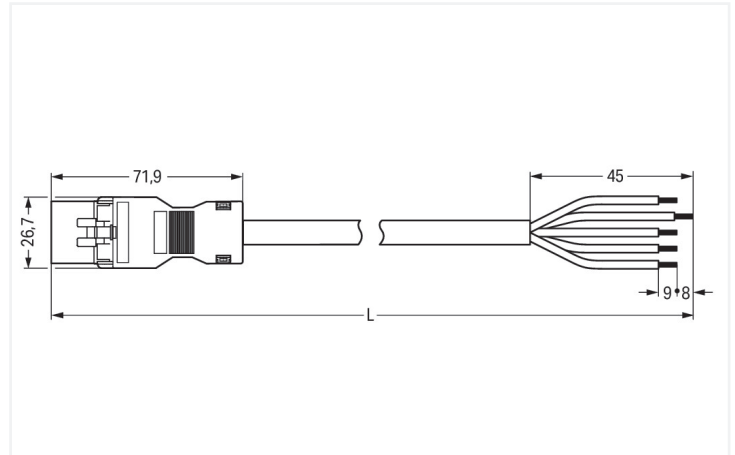

Dimensions in mm

Cable assembly WINSTA® MINI with protection against mismatching

For signal and power transmission: The WINSTA® MINI cable assembly rated current 13 A. The pluggable installation connectors with spring pressure connection technology function entirely without screw connections. They allow flexible, error-free installation in a large number of applications. For greater security in electrical installations, the pluggable installation connector is provided with mechanical protection against mismatching. Thanks to the color coding and mechanical A coding of WINSTA® MINI pluggable installation connectors, you can clearly distinguish different circuits. Particularly if only limited space is available, our smallest pluggable connection system, WINSTA® MINI, conveniently displays its advantages. It is very compact, and, thanks to Push-in CAGE CLAMP® spring pressure connection technology, it additionally saves time, since the installation is low-maintenance and can be performed without screw connections. According to the European CPR, the fire class of the cables used in construction is critical for building safety, too. For houses with medium-level safety requirements, cable assemblies with fire class E are suitable.

Fast, error-free assembly thanks to cable assemblies from WAGO

A plug and a free end are provided. The WINSTA® Pluggable Connection System is perfectly tailored to the very strict requirements of building installation. It makes electrical installation pluggable, and thus more efficient, more reliable, and error-free. Using this pre-assembled system decreases assembly times and errors during installation at the construction site. Enjoy the benefits of the pluggable version of our maintenance-free spring pressure connection technology too! Plan your installation with with protection type IP20 from WAGO.

- effective protection against mismatching
- compact design for conductors with a cross-section up to 1.5 mm²
- suitable for any application
- custom-engineered solutions
- rapid, structured electrical installation

Notes

Note

Cables with a different fire class can be found in the eShop.

Electrical data

Ratings per	IEC/EN 60664-1		
Overvoltage category	III	III	II
Pollution degree	3	2	2
Nominal voltage	400 V	-	-
Rated impulse withstand voltage	6 kV	-	-
Rated current	13 A	-	-

General information

Note on contact resistance	approx. 1 mΩ of contact resistance approx. 0.25 mΩ contact transition plug/ socket
----------------------------	--

Connection Data

Total number of potentials	5
Conductor preparation	ultrasonically tip-bonded

Connection 1

Strip length	9 mm / 0.35 inches
Pole number	5
Wire cross-section	1.5 mm ²
Strip length (outer insulation)	45 mm
Connection type	Plug - free end

Physical data

Pin spacing	4.4 mm / 0.173 inches
Width	26.7 mm / 1.051 inches
Height	15.8 mm / 0.622 inches
Total length	4 m

Mechanical data

Use	General mains applications
Coding	A
Variable coding	No
Marking	N ⊕ 1 2 3
Potential marking	N ⊕ 1 2 3
Mating force of a plug-in connection	approx. 20 ... 70 N (depending on pole number)
Retention force of a plug-in connection	when locked: > 80N
Unmating force of a plug-in connection	when unlocked: approx. 20 ... 70 N (depending on pole number)
Number of mating cycles	200, without resistive load
Connection type	Plug - free end
Type of pre-assembled cable	Connecting cable
Cable type	H05VV-F 5G1.5
Protection type	IP20; IP40 when mated

Plug-in connection

Mismating protection	Yes
Note on mismating protection	All WINSTA® components are 100% protected against mismating when: a.) plugging different numbers of poles b.) plugging while rotated 180 c.) plugging while laterally staggered d.) plugging one pole
Locking lever	Can be retrofitted
Locking of plug-in connection	Locking lever
Note on locking system	All connectors for mounted installations (snap-in versions for lighting fixtures or devices, all types of PCB and distribution connectors) are factory-equipped with locking levers to ensure plugs and sockets are securely locked. Additional locking levers are only required for flying leads (plug/socket).

Material data

Note (material data)	Information on material specifications can be found here
Color	white
Insulation material (main housing)	Polyamide (PA66)
Fire class per EN 50575	E _{ca}
Contact material	Copper or copper alloy; surface-treated
Contact Plating	Tin
Fire load	119.98 MJ
Connector color	white
Strain relief color	white
Sheathed cable color	white
Printing color of sheathed cable	black
Halogen-free	No
Silicon-free	Yes
Sheath material	PVC
Rubber cable	No
Weight	630.2 g
Copper weight of the raw cable	0.072 kg/m

Environmental requirements

Processing temperature	-5 ... +40 °C
Continuous operating temperature	-35 ... +85 °C
Note on continuous operating temperature	Cable for temperatures ≤ 70 °C (including halogen-free) Insulating parts for temperatures ≤ 105 °C

Commercial data

PU (SPU)	1 pcs
Packaging type	unpacked
Country of origin	PL
GTIN	4055143398923
Customs tariff number	85444290900

Product Classification

UNSPSC	26121629
eCl@ss 10.0	27-44-06-04
eCl@ss 9.0	27-44-06-04
ETIM 9.0	EC002587
ETIM 10.0	EC002587
ECCN	NO US CLASSIFICATION

Environmental Product Compliance

RoHS Compliance Status	Compliant, No Exemption
------------------------	-------------------------

Approvals / Certificates

General approvals



Approval	Standard	Certificate Name
CCA DEKRA Certification B.V.	EN 61535	NTR NL-7971
KEMA/KEUR DEKRA Certification B.V.	EN 61535	71-123232

Declarations of conformity and manufacturer's declarations

Approval	Standard	Certificate Name
EU-Declaration of Confor- mity WAGO GmbH & Co. KG	-	-
UK-Declaration of Confor- mity WAGO GmbH & Co. KG	-	-

Downloads

Environmental Product Compliance

Compliance Search

Environmental Product Compliance 891-8995/206-402	↓
---	-------------------

Documentation

Bid Text

891-8995/206-402	19.02.2019	xml 2.98 KB	↓
891-8995/206-402	01.12.2014	doc 25.00 KB	↓

CAD/CAE-Data

CAE data

EPLAN Data Portal 891-8995/206-402	↓
WSCAD Universe 891-8995/206-402	↓

1 Compatible Products

1.1 Required Accessories

1.1.1 Locking system

1.1.1.1 Locking system



[Item No.: 890-111](#)
Locking lever; for flying leads; for tool operation; black

[Item No.: 890-131](#)
Locking lever; for flying leads; for tool operation; white

[Item No.: 890-101](#)
Locking lever; for manual operation; black

[Item No.: 890-121](#)
Locking lever; for manual operation; white

1.2 Optional Accessories

1.2.1 Cover

1.2.1.1 Cover



Item No.: [897-2003](#)

Protective cap; Type2; for sockets and plugs; PVC; red

1.2.2 Installation

1.2.2.1 Mounting accessories



Item No.: [890-310](#)

Mounting carrier; 2- to 5-pole; for flying leads; black



Item No.: [890-311](#)

Mounting carrier; 2- to 5-pole; for flying leads; white