

Data Sheet | Item Number: 771-8992/117-801

pre-assembled connecting cable; Eca; Socket/open-ended; 2-pole; Cod. A;
H05Z1Z1-F 2 x 2.5 mm²; 8 m; 2,50 mm²; black

<https://www.wago.com/771-8992/117-801>

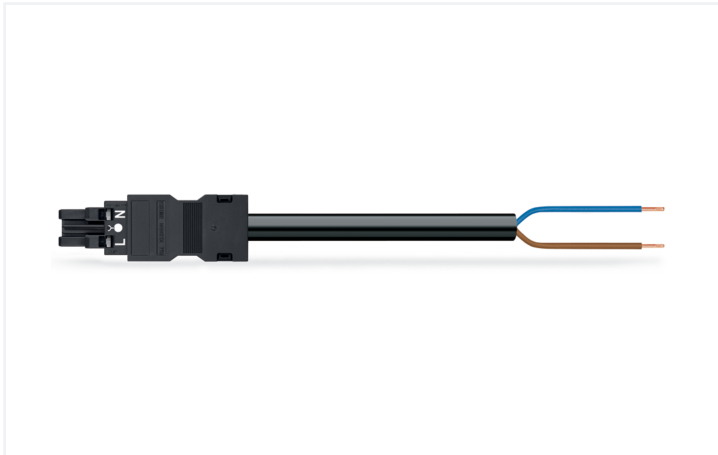

Color: ■ black

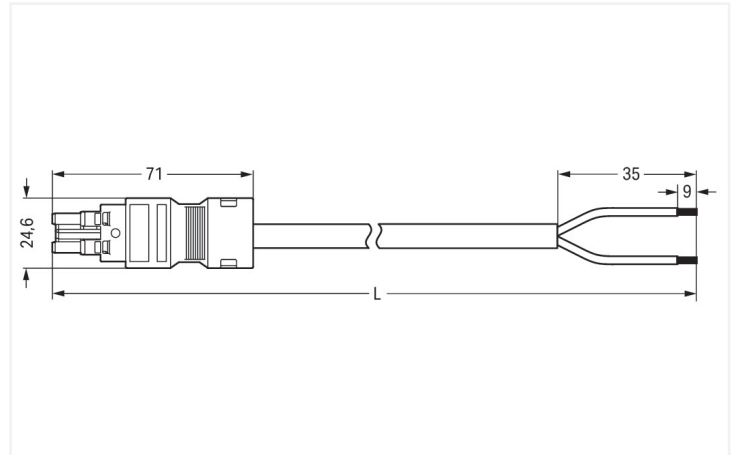

Dimensions in mm

Cable assembly WINSTA® MIDI with protection against mismatching

For signal and power transmission: The WINSTA® MIDI cable assembly A coding. The pluggable installation connectors with spring pressure connection technology function completely without screw connections. They allow resource-efficient, error-free installation in numerous possible uses. The mechanical coding and color coding of the pluggable installation connector ensure error-free installation of the individual components – including protection against mismatching. The pluggable installation connector is protected in accordance with protection type IP20 (When mated: IP2xC (These compact connectors are not designed for use in open, easily accessible areas!)). That results in the fact that users' fingers will never come into contact with energised elements. The WINSTA® MIDI pluggable installation connector with A coding in black or white is usually used for general mains applications in power distribution. This pluggable installation connector can be used for electrical currents up to 20 A. Thus the product is ideally suitable for high power loads. The WINSTA® MIDI Pluggable Connection System with Push-in CAGE CLAMP® spring pressure connection technology facilitates precise electrification. Thanks to the built-in test slot, connections can be checked even when they are plugged in. That saves time and reduces installation labor and costs. Of course, the safety of buildings must always be ensured, even after the electrical installation has been performed. The required safety requirements in connection with EU CPR are fully satisfied by this product through fire class E. In the production of this cable assembly, halogens were deliberately omitted. That is an important contribution to climate protection.

Pluggable connections instead of screw connections – cable assemblies from WAGO

The cable is pre-assembled with a socket and a free end. The WINSTA® Pluggable Connection System is perfectly tailored to the strict requirements of building installation. It makes electrical installation pluggable, and thus faster, more reliable, and error-free. Use of this pre-assembled system decreases assembly times and errors during installation at the construction site. Now you can also reduce installation expenses without compromising safety and quality: with protection type IP20 reduces the need for servicing and prevents unnecessary downtime.

- effective protection against mismatching
- for automation controllers
- with A coding for use in a large number of general mains applications
- flexible installation to save space
- rapid, structured electrical installation

Notes

Note Cables with a different fire class can be found in the eShop.

Electrical data

Ratings per	IEC/EN 60664-1			General information	
Overvoltage category	III	III	II	Note on contact resistance	approx. 1 mΩ of contact resistance approx. 0.25 mΩ contact transition plug/ socket
Pollution degree	3	2	2		
Nominal voltage	250 V	-	-		
Rated impulse withstand voltage	4 kV	-	-		
Rated current	20 A	-	-		

Connection Data

Total number of potentials	2	Connection 1	
Conductor preparation	ultrasonically tip-bonded	Strip length	9 mm / 0.35 inches
		Pole number	2
		Wire cross-section	2.5 mm ²
		Strip length (outer insulation)	35 mm
		Connection type	Socket - free end

Physical data

Pin spacing	10 mm / 0.394 inches
Width	24.6 mm / 0.969 inches
Height	15.9 mm / 0.626 inches
Total length	8 m

Mechanical data

Use	General mains applications
Coding	A
Variable coding	No
Marking	L N
Potential marking	L N
Mating force of a plug-in connection	approx. 20 ... 70 N (depending on pole number)
Retention force of a plug-in connection	when locked: > 80N
Unmating force of a plug-in connection	when unlocked: approx. 20 ... 70 N (depending on pole number)
Number of mating cycles	200, without resistive load
Connection type	Socket - free end
Type of pre-assembled cable	Connecting cable
Cable type	H05Z1Z1-F 2x2.5
Protection type	IP20; When mated: IP2xC (These compact connectors are not designed for use in open, easily accessible areas!)

Plug-in connection

Mismating protection	Yes
Note on mismating protection	All WINSTA® components are 100% protected against mismating when: a.) plugging different numbers of poles b.) plugging while rotated 180 c.) plugging while laterally staggered d.) plugging one pole
Locking lever	Can be retrofitted
Locking of plug-in connection	Locking lever
Note on locking system	All connectors for mounted installations (snap-in versions for lighting fixtures or devices, all types of PCB and distribution connectors) are factory-equipped with locking levers to ensure plugs and sockets are securely locked. Additional locking levers are only required for flying leads (plug/socket).

Material data

Note (material data)	Information on material specifications can be found here
Color	black
Insulation material (main housing)	Polyamide (PA66)
Fire class per EN 50575	E _{ca}
Contact material	Copper or copper alloy; surface-treated
Contact Plating	Tin
Fire load	239.677 MJ
Connector color	black
Strain relief color	black
Sheathed cable color	black
Printing color of sheathed cable	white
Halogen-free	Yes
Silicon-free	Yes
Sheath material	Halogen-free
Rubber cable	No
Weight	1026.4 g
Copper weight of the raw cable	0.048 kg/m

Environmental requirements

Processing temperature	-5 ... +40 °C
Continuous operating temperature	-35 ... +85 °C
Note on continuous operating temperature	Cable for temperatures ≤ 70 °C (including halogen-free) Insulating parts for temperatures ≤ 105 °C

Commercial data

PU (SPU)	1 pcs
Packaging type	unpacked
Country of origin	DE
GTIN	4055143479783
Customs tariff number	85444290900

Product Classification

UNSPSC	26121629
eCl@ss 10.0	27-44-06-04
eCl@ss 9.0	27-44-06-04
ETIM 9.0	EC002587
ETIM 10.0	EC002587
ECCN	NO US CLASSIFICATION

Environmental Product Compliance

RoHS Compliance Status	Compliant, No Exemption
------------------------	-------------------------

Approvals / Certificates

General approvals			Declarations of conformity and manufacturer's declarations		
Approval	Standard	Certificate Name	Approval	Standard	Certificate Name
CCA DEKRA Certification B.V.	EN 61535	NTR NL-7972	EU-Declaration of Confor- mity WAGO GmbH & Co. KG	-	-
KEMA/KEUR DEKRA Certification B.V.	EN 61535	71-123834	UK-Declaration of Confor- mity WAGO GmbH & Co. KG	-	-

Downloads

Environmental Product Compliance

Compliance Search	
Environmental Product Compliance 771-8992/117-801	↓

Documentation

Bid Text			
771-8992/117-801	19.02.2019	xml 2.97 KB	↓
771-8992/117-801	03.12.2014	doc 26.50 KB	↓

CAD/CAE-Data

CAE data	
EPLAN Data Portal 771-8992/117-801	↓
WSCAD Universe 771-8992/117-801	↓

1 Compatible Products

1.1 Required Accessories

1.1.1 Cover

1.1.1.1 Cover



Item No.: 770-201

Lockout cap; 12-pole, separable; for sockets; Plastic; black



Item No.: 770-221

Lockout cap; 12-pole, separable; for sockets; Plastic; white

1.1.2 Locking system

1.1.2.1 Locking system



Item No.: 770-101

Locking lever; for flying leads; for manual operation; black



Item No.: 770-121

Locking lever; for flying leads; for manual operation; white



Item No.: 770-111

Locking lever; for flying leads; for tool operation; black



Item No.: 770-131

Locking lever; for flying leads; for tool operation; white

1.2 Optional Accessories

1.2.1 Cover

1.2.1.1 Cover



Item No.: 897-2003

Protective cap; Type2; for sockets and plugs; PVC; red

1.2.2 Installation

1.2.2.1 Mounting accessories



Item No.: 770-310

Mounting carrier; 2- to 5-pole; for flying leads; black

1.2.3 Marking

1.2.3.1 Marking strip



Item No.: 210-334

Marking strips; as a DIN A4 sheet; Strip width 5 mm; Strip length 182 mm; plain; Self-adhesive; white