

Data Sheet | Item Number: 891-8994/216-401

pre-assembled connecting cable; Eca; Plug/open-ended; 4-pole; Cod. A; H05Z1Z1-F 4G 1.5 mm²; 4 m; 1,50 mm²; black

<https://www.wago.com/891-8994/216-401>

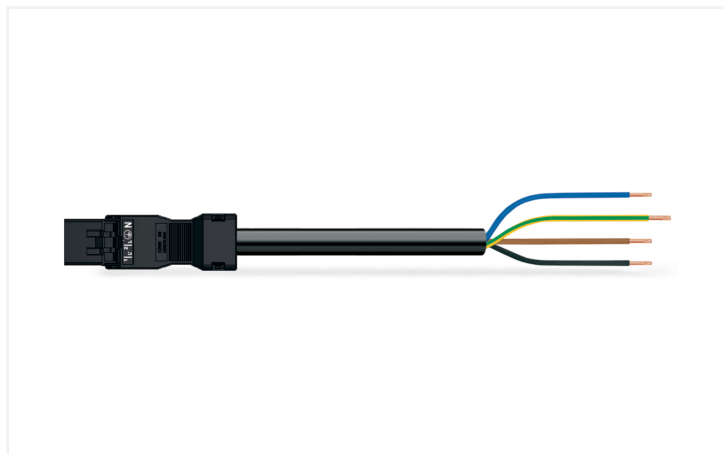

Color: ■ black

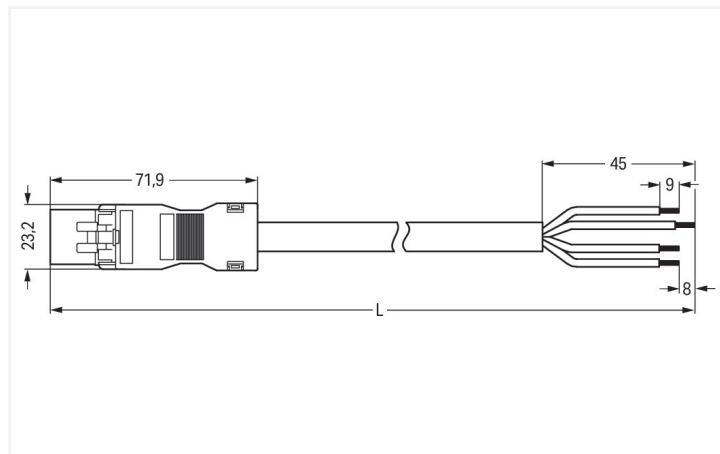

Dimensions in mm

Cable assembly WINSTA® MINI with strain relief

The WINSTA® MINI cable assembly A coding is the pluggable solution for your use in control cabinets, on PCBs or for lighting connections. WAGO pluggable installation connectors are used when criteria repeat or are distributed on a specific grid, for example for installing grid lighting or flush-mount lighting. The coding options reduce installation errors, allowing fast, secure wiring of all components. Standard mains applications for almost any domain of use can be realised with WINSTA® MINI pluggable installation connectors with A coding. WINSTA® MINI follows the trend towards miniaturisation. Our smallest pluggable connection system is very good for lights, for instance, since as a result of LED technology; due to complex systems, these offer much less space for the connection technology. This product meets all the mandatory safety requirements of fire class E; as a result it can be used in areas where fire safety is relevant. The cable assembly is free of halogen. This eliminates the addition of environmental pollutants during production. It also increases the fire class, since halogen-free materials do not easily ignite.

Fast, secure pluggable connections – cable assemblies from WAGO

The cable assembly is provided with a plug and a free end. WINSTA® is the pluggable connection system that is perfectly tailored to the strict requirements of electrical installation. It allows error-free installation of cables and components, quickly and reliably. Take advantage of the pluggable version of our maintenance-free spring pressure connection technology too! Plan your installation with with protection against mismatching from WAGO.

- pluggable installation connectors with protection against mismatching
- consistent IP40 protection
- with A coding for a large number of uses
- ready to install and use immediately
- fast, secure installation

Notes

Note Cables with a different fire class can be found in the eShop.

Electrical data

Ratings per	IEC/EN 60664-1		
Overvoltage category	III	III	II
Pollution degree	3	2	2
Nominal voltage	400 V	-	-
Rated impulse withstand voltage	6 kV	-	-
Rated current	16 A	-	-

General information

Note on contact resistance approx. 1 mΩ of contact resistance
approx. 0.25 mΩ contact transition plug/ socket

Connection Data

Total number of potentials	4	Connection 1	
PE function	Preceding PE contact	Strip length	9 mm / 0.35 inches
Conductor preparation	ultrasonically tip-bonded	Pole number	4
		Wire cross-section	1.5 mm ²
		Strip length (outer insulation)	45 mm
		Connection type	Plug - free end

Physical data

Pin spacing	4.4 mm / 0.173 inches
Width	23.2 mm / 0.913 inches
Height	16 mm / 0.63 inches
Total length	4 m

Mechanical data

Use	General mains applications
Coding	A
Variable coding	No
Marking	N ⊕ 2/L 1/L'
Potential marking	N ⊕ 2/L 1/L'
Mating force of a plug-in connection	approx. 20 ... 70 N (depending on pole number)
Retention force of a plug-in connection	when locked: > 80N
Unmating force of a plug-in connection	when unlocked: approx. 20 ... 70 N (depending on pole number)
Number of mating cycles	200, without resistive load
Connection type	Plug - free end
Type of pre-assembled cable	Connecting cable
Cable type	H05Z1Z1-F 4G1.5
Protection type	IP20; IP40 when mated

Plug-in connection

Mismating protection	Yes
Note on mismating protection	All <i>WINSTA</i> ® components are 100% protected against mismating when: a.) plugging different numbers of poles b.) plugging while rotated 180 c.) plugging while laterally staggered d.) plugging one pole
Locking lever	Can be retrofitted
Locking of plug-in connection	Locking lever
Note on locking system	All connectors for mounted installations (snap-in versions for lighting fixtures or devices, all types of PCB and distribution connectors) are factory-equipped with locking levers to ensure plugs and sockets are securely locked. Additional locking levers are only required for flying leads (plug/socket).

Material data

Note (material data)	Information on material specifications can be found here
Color	black
Insulation material (main housing)	Polyamide (PA66)
Fire class per EN 50575	E _{ca}
Contact material	Copper or copper alloy; surface-treated
Contact Plating	Tin
Fire load	119.92 MJ
Connector color	black
Strain relief color	black
Sheathed cable color	black

Material data

Printing color of sheathed cable	white
Halogen-free	Yes
Silicon-free	Yes
Sheath material	Halogen-free
Rubber cable	No
Weight	481.2 g
Copper weight of the raw cable	0.058 kg/m

Environmental requirements

Processing temperature	-5 ... +40 °C
Continuous operating temperature	-35 ... +85 °C
Note on continuous operating temperature	Cable for temperatures ≤ 70 °C (including halogen-free) Insulating parts for temperatures ≤ 105 °C

Commercial data

PU (SPU)	1 pcs
Packaging type	unpacked
Country of origin	PL
GTIN	4055143405164
Customs tariff number	85444290900

Product Classification

UNSPSC	26121629
eCl@ss 10.0	27-44-06-04
eCl@ss 9.0	27-44-06-04
ETIM 9.0	EC002587
ETIM 10.0	EC002587
ECCN	NO US CLASSIFICATION

Environmental Product Compliance

RoHS Compliance Status	Compliant, No Exemption
------------------------	-------------------------

Approvals / Certificates

General approvals



Approval	Standard	Certificate Name
CCA DEKRA Certification B.V.	EN 61535	NTR NL-7971
KEMA/KEUR DEKRA Certification B.V.	EN 61535	71-123232

Downloads

Environmental Product Compliance

Compliance Search

Environmental Product Compliance
891-8994/216-401



Documentation

Bid Text

891-8994/216-401	19.02.2019	xml 3.01 KB	
891-8994/216-401	01.12.2014	doc 25.00 KB	

CAD/CAE-Data

CAE data

EPLAN Data Portal
891-8994/216-401



WSCAD Universe
891-8994/216-401



1 Compatible Products

1.1 Required Accessories

1.1.1 Locking system

1.1.1.1 Locking system



[Item No.: 890-111](#)

Locking lever; for flying leads; for tool operation; black

[Item No.: 890-131](#)

Locking lever; for flying leads; for tool operation; white

[Item No.: 890-101](#)

Locking lever; for manual operation; black

[Item No.: 890-121](#)

Locking lever; for manual operation; white

1.2 Optional Accessories

1.2.1 Cover

1.2.1.1 Cover



[Item No.: 897-2003](#)

Protective cap; Type2; for sockets and plugs; PVC; red

1.2.2 Installation

1.2.2.1 Mounting accessories



Item No.: 890-310

Mounting carrier; 2- to 5-pole; for flying leads; black

Item No.: 890-311

Mounting carrier; 2- to 5-pole; for flying leads; white