



**EATON**

*Powering Business Worldwide*



We make what matters work.\*



At Eaton, we believe that power is a fundamental part of just about everything people do. That's why we're dedicated to helping our customers find new ways to manage electrical, hydraulic and mechanical power more efficiently, safely and sustainably. To improve people's lives, the communities where we live and work, and the planet our future generations depend upon. Because this is what really matters. And we're here to make sure it works.

To learn more go to: [Eaton.com/whatmatters](https://www.eaton.com/whatmatters)

**EATON**

*Powering Business Worldwide*

**We make what matters work.**

# Table of content

<b>North American fuse links</b> . . . . .	<b>7</b>
250 V d.c. (UL) - 35 A to 800 A - FWX . . . . .	7
500 V d.c. (UL) - 50 A to 400 A - CHSF . . . . .	9
500 V d.c. (UL) - 35 A to 900 A - FWH . . . . .	12
700 V d.c.(UL) - 5 A to 800 A - FWP-B . . . . .	15
1000 V d.c. (IEC/UL) - 70 A to 600 A - FWE . . . . .	20
<b>British standard BS88 fuse links</b> . . . . .	<b>26</b>
500 V d.c. (IEC), 700 V d.c. (UL) - 35 A to 200 A - FE, EET, FEE . . . . .	26
<b>Ferrule fuse links</b> . . . . .	<b>33</b>
250 V d.c. (IEC/UL) - 80 A to 315 A - BSF-DD25 . . . . .	31
600 V d.c. (UL) - 5 A to 63 A - FWP - 14 x 51 mm . . . . .	33
1000 V d.c. (IEC), 1125 V d.c. (UL) - 12 A to 30 A - 180D - 10 x 85 mm . . . . .	36
<b>Square body fuse links</b> . . . . .	<b>39</b>
500 V d.c. (IEC/UL) - 50 A to 500 A - 180D - Flush end contact fuse body size 1* . . . . .	39
800 V d.c. (IEC/UL) - 32 A to 50 A - 180D - DIN1HT Fuse body size 1 . . . . .	45
800 V d.c. (IEC/UL) - 500 A to 630 A - 180D - Flush end contact and DIN Fuse body size 1 . . . . .	48
800 V d.c. (IEC), 900 V d.c. (UL) - 50 A to 350 A - 180D - Flush end contact fuse body size 1* . . . . .	52
800 V d.c. (IEC), 900 V d.c. (UL) - 160 A to 450 A - 180D - Flush end contact and DIN Fuse body size 1 . . . . .	57
800 V d.c. (IEC), 900 V d.c. (UL) - 315 A to 800 A - 180D - Flush end contact and DIN Fuse body size 3 . . . . .	62
800 V d.c. (IEC), 900 V d.c. (UL) - 1000 A to 1600 A - 180D - Flush end contact fuse body size 23 . . . . .	66
800 V d.c. (IEC), 900 V d.c. (UL) - 630 A to 2200 A - 180D - Flush end contact fuse body size 23 . . . . .	69
1000 V d.c. (IEC) - 63 A to 400 A - BSF-NH - NH Style . . . . .	72
1000 V d.c. (IEC/UL) - 250 A to 550 A - 180D - Flush end contact fuse body size 2 . . . . .	78
1000 V d.c. (UL) - 700 A to 1000 A - 180D - Flush end contact fuse body size 2 . . . . .	81
1000 V d.c. (IEC), 1125 V d.c. (UL) - 50 A to 125 A - 180D - Square body bladed size 01HT . . . . .	84
1000 V d.c. (IEC), 1125 V d.c. (UL) - 125 A to 250 A - 180D - Square body bladed size 2HT . . . . .	87
1000 V d.c. (IEC), 1125 V d.c. (UL) - 250 A to 500 A - 180D Square body bladed size 3HT . . . . .	90
1500 V d.c. (IEC/UL) - 100 A to 315 A - 180D - Flush end, DIN and US Style contact fuse size 1 . . . . .	93
1500 V d.c. (IEC/UL) - 100 A to 450 A - ESS2 and ESS2-NI - Size 2 . . . . .	97
1500 V d.c. (IEC/UL) - 125 A to 500 A - 180D - Flush end, DIN and US Style contact fuse size 2 . . . . .	105
1500 V d.c. (IEC/UL) - 100 A to 630 A - ESS3 and ESS3-NI - Size 3 . . . . .	110
1500 V d.c. (IEC/UL) - 350 A to 1400 A - 180D - Flush end, DIN and US Style contact fuse size 3 . . . . .	114
1500 V d.c. (IEC) - 250 A to 500 A - BSF-3XL - XL Style . . . . .	119
1500 V d.c. (IEC/UL) - 800 A to 1800 A - 180D - Flush end contact fuse body size 4 . . . . .	122
1500 V d.c. (IEC/UL) - 630 A to 1800 A - ESS5 - Size 4 . . . . .	125
1500 V d.c. (IEC/UL) - 1600 A to 3000 A - 180D - Size 24 . . . . .	128
2000 V d.c. Battery Energy Storage System (BESS) fuses . . . . .	131
<b>Photovoltaic fuse links, fuse bases and holders</b> . . . . .	<b>132</b>
600 V d.c. (UL) - 4 A to 30 A - PVM - 10 x 38 mm . . . . .	132
1000 V d.c. (IEC/UL) - 1 A to 20 A - PV-A10 - 10 x 38 mm . . . . .	134
CHPV Modular fuse holders for 10 x 38 mm fuse links - 1000 V d.c. (IEC/UL) - 32 A (IEC), 30 A (UL) . . . . .	137
1000 V d.c. (IEC/UL) - 32 A to 400 A - NH - PV-ANH . . . . .	138
SD-D-PV fuse base for NH fuse links - 1500 V d.c. (IEC) - 1000 V d.c. (UL/CSA) - 250 A to 630 A . . . . .	146
1000 V d.c. (IEC/UL) - 160 A to 400 A - PV-AF - Flush end . . . . .	148
1000 and 1100 V d.c. (IEC/UL) - 15 A to 32 A - PV-14F - 14 x 51 mm . . . . .	151
CHPV14 Modular fuse holder for 14 x 51 mm fuse links - 1500 V d.c. - 50 A . . . . .	153
1500 V d.c. (IEC/UL) - 2.25 A to 30 A - PV-A10F85L - 10 x 85 mm . . . . .	154
CHPV15H85 fuse holder for 10 x 85 mm fuse links - 1500 V d.c. - 32 A (IEC/UL) . . . . .	156
1300-1500 V d.c. (IEC and UL) - 2.25 A to 32 A - PV-14L - 14 x 65 mm . . . . .	157
1000-1500 V d.c. (IEC/UL) - 50 A to 600 A - PV-XL and PVS-3L - XL and 3L Style . . . . .	160
SD-S-PV Fuse base for XL and PVS fuse links - 1500 V d.c. (IEC) - 200 A to 500 A . . . . .	171
2000 V d.c. Photovoltaic fuses . . . . .	172
<b>Index</b> . . . . .	<b>173</b>

Welcome to our DC High Speed Fuse catalogue, designed to meet the needs of modern electrical and energy systems. With growing demand for reliable DC overcurrent protection, our range offers validated high speed fuses for a variety of industrial and commercial applications. Engineered for rapid, dependable fault interruption and compliant with global standards, our fuses ensure safety and uninterrupted operation. Explore the catalogue for detailed product specifications.

## Introduction to DC High speed fuses

Direct current (DC) systems present unique challenges in overcurrent protection, as the interruption of DC faults is inherently more complex than that of alternating current (AC) systems. This complexity arises from the absence of natural current zero points in DC, which makes arc extinction more demanding and heightens the risk of system damage if faults are not cleared rapidly. Our highspeed DC fuses are engineered to address these challenges head-on, ensuring that your systems remain protected under even the most demanding conditions.

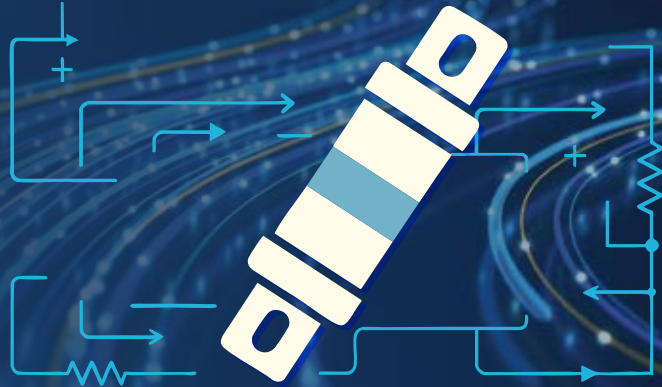

### Key applications for DC High speed fuses

Our DC-validated High speed fuses are designed for rapid interruption of fault currents, making them indispensable in critical applications where safety, reliability, and system uptime are paramount. These fuses are ideally suited for:



**Battery Energy Storage Systems (BESS):** With the global push for renewable energy integration, battery storage is becoming an essential component of modern grids. Our High speed DC fuses provide the fast fault interruption needed to protect valuable battery arrays and ensure safe operation.



**Photovoltaic (PV) systems:** Solar energy systems, particularly large-scale arrays, require rapid overcurrent protection to prevent equipment damage and ensure fire safety. Our fuses are validated for PV applications, offering peace of mind for system designers and operators.



**DC Charging stations:** As electric vehicle (EV) adoption accelerates, DC fast chargers are increasingly common place. Our fuses deliver reliable fault interruption, protecting sensitive power electronics and ensuring user safety.



**Data Centres:** The rapid increase in rack power density and the drive for higher power and space utilisation efficiency are accelerating the adoption of  $\pm 400V$  or  $800V$  DC facility-level distribution in Data Centres. As critical infrastructure, these applications demand robust electrical protection, where DC High speed fuses play a vital role in ensuring system safety and reliability.



**Emerging industrial technologies:** From hydrogen electrolysis to advanced manufacturing processes, any application involving significant DC power transfer benefits from High speed fuse protection.

For further technical guidance tailored to your system, please consult our BES Application guide and PV Applications Guide. If your focus is on AC system protection, refer to our dedicated AC High Speed Fuse Catalogue via the provided HSF Catalogue link.

## DC Fuse selection: key considerations

Selecting the correct fuse for a DC application is critical to ensuring optimal system reliability and protection. Here are the core factors you must consider:

### 1. Voltage rating

The voltage rating of a fuse determines the maximum DC voltage at which it can safely operate. It is essential that the fuse's voltage rating is at least equal to, or greater than, your system voltage. Underrated fuses may fail to interrupt fault currents properly, posing significant risks to equipment and personnel.

Our High speed fuse links are designed to meet stringent international standards, including UL 248-13, IEC 60269 Parts 1 & 4, and BS88. This guarantees broad applicability and consistent performance in global markets.

### 2. Current rating

A fuse's current rating reflects the root mean square (RMS) current it can continuously carry without exceeding defined temperature limits. Selecting a fuse with an appropriate current rating ensures longevity and reliable protection. Exceeding this rating will compromise fuse life and system safety.

### 3. Time constant considerations

The time constant of your system, essentially, how fast current decays in a circuit after a fault, must be matched or exceeded by the fuse's tested time constant. This ensures the fuse can reliably interrupt a fault without delay, especially in systems with high inductance or rapid current changes.

### 4. Fuse clearing time

Clearing time refers to how quickly the fuse can interrupt a fault current. Lower time constants allow for faster fault clearing, which minimises the risk of downstream equipment damage by limiting the exposure to excessive fault currents. Efficient clearing is especially critical in sensitive DC applications.

## Why choose our High speed DC Fuses?

Our product line stands out in several ways, delivering tangible benefits for engineers, installers, and end-users alike.



**Optimized performance:** Our High speed fuses are specifically developed to minimise let-through energy ( $I^2t$ ), peak current, and arc voltage. This results in rapid element melting and near-instantaneous fault clearance, a crucial factor in protecting DC systems such as photovoltaics, battery storage, and charging networks.



**Reliability and safety:** Consistency is at the core of our design philosophy. Our products deliver dependable protection, in line with international safety standards, for both your equipment and personnel. Each fuse is thoroughly tested to ensure reliable operation, even under challenging conditions.



**Compliance with industry standards:** Safety and performance are underpinned by full compliance with latest standards including IEC-60269, IEC-63523, and UL-248. This means our fuses are recognised for their quality in both North American and global markets.



**Comprehensive portfolio and scalable solutions:** We offer a wide variety of fuse styles and current ratings, enabling coordinated selection across diverse system sizes and requirements. Whether your project is a large-scale renewable farm or a compact industrial system, scalable protection is available.

## Application engineering support

Navigating the complexities of High speed fuse selection can be challenging—especially for DC systems, where the protection requirements are even more exacting than those of AC systems. Our experienced application engineering team is ready to offer expert technical advice, ensuring you select the most appropriate High speed fuse for your unique application.

To consult with our application engineering specialists, please contact:

Phone: **00 44 (0) 1509 882 699**

Email: [bulehighspeedtechnical@eaton.com](mailto:bulehighspeedtechnical@eaton.com)

## Custom solutions for unique needs

No two projects are identical, and unique operational demands may require customised protection solutions. We are proud to offer bespoke fuse designs, tailored to your specific requirements. Options include:

- Extended current and voltage ratings beyond standard offerings
- Custom mounting solutions for integration into specialised assemblies
- Varied connection types suited to your system architecture
- Specialised testing to meet unique operational criteria or regulatory requirements

Our collaborative approach ensures you receive a solution that fits seamlessly into your system, delivering both safety and performance.

# Struggling to find the right fuse for your application?



**Eaton's Field Applications Engineers are able to draw upon more than 100 years of fuse design knowledge to fully meet your application needs and ensure you can rely on the best in class electrical circuit protection solutions.**

As the trend towards clean energy continues to drive new technologies in renewable energy generation, energy storage, electrical transportation and the adoption of DC technology throughout wider industries, the demand for customised fusing products has only increased.

Our Application and Design Engineers located at R&D centres in North America, Europe and Asia can leverage over 100 years of fuse design and application experience along with our in-house test labs to meet any customised solution requests for **Eaton's Bussmann series fuses**.

#### **Our services include:**

- New current/voltage ratings
- Design to meet I2t requirements
- Customised mounting connection and plating materials
- Modify indicator locations/ add or remove indicators
- Special end connections
- Acquire UL/IEC/CCC/CSA certificates
- Customised testing such as shock vibration
- Higher breaking capacity testing

#### **Contact us today:**

**For general fuse enquiries:** [buletechnical@eaton.com](mailto:buletechnical@eaton.com)

**For high speed fuses enquiries :**  
[bulehighspeedtechnical@eaton.com](mailto:bulehighspeedtechnical@eaton.com)

# EATON

*Powering Business Worldwide*

## We make what matters work.

# North American fuse links

## 250 V d.c. (UL) - 35 A to 800 A - FWX

### Specifications

#### Description

North American style bolted tags high speed fuse links for the protection of DC common bus, DC drives, power converters/rectifiers and reduced rated voltage starters.

#### Technical Data

- Rated voltage: 250 V d.c. (UL)
- Rated current: 35 A to 800 A
- Breaking capacity: 50 kA at 250 V d.c.

#### Standards / Agency information

CE, UL Recognised file JFHR2.E56412 and CSA component acceptance on 35 A to 800 A fuse links (50 kA IR at 250 V d.c.)



### Catalog numbers

Rated voltage	Rated current (Amps)	$I^2t$ (A <sup>2</sup> Sec)		Watts loss (W)	Catalog numbers
		Pre-arcing			
250 V d.c. (UL)	35	50		4.2	FWX-35A
	40	60		5.2	FWX-40A
	45	80		5.7	FWX-45A
	50	100		6	FWX-50A
	60	140		8.1	FWX-60A
	70	330		7.2	FWX-70A
	80	430		8.1	FWX-80A
	90	570		9	FWX-90A
	100	740		10	FWX-100A
	125	1130		12.5	FWX-125A
	150	1620		15.7	FWX-150A
	175	2170		18.5	FWX-175A
	200	2790		22	FWX-200A
	225	3210		24	FWX-225A
	250	3960		27	FWX-250A
	275	4720		31	FWX-275A
	300	6000		32	FWX-300A
	350	10,600		39	FWX-350A
	400	14,500		44	FWX-400A
	450	22,100		49	FWX-450A
500	28,000		54	FWX-500A	
600	41,100		62	FWX-600A	
700	48,800		72	FWX-700A	
800	59,000		84	FWX-800A	

### Dimensions (mm)

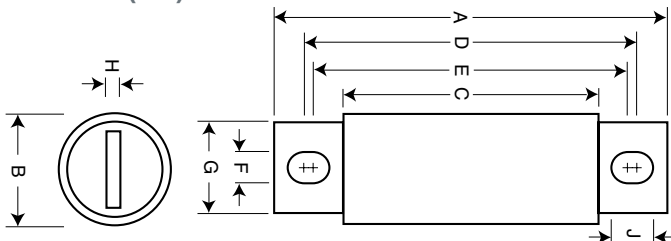

Amp range	A	B	C	D	E	F	G	H	J
35-60	81	20.5	40.4	65.8	57.1	8.6	16	3.3	13.2
70-200	79.5	31	40.4	61.9	55.6	8.6	25.4	4.8	11.9
225-600	97.5	38.1	40.4	74.7	57.1	10.4	25.4	6.3	19
700-800	97.5	50.8	40.4	76.9	57.9	10.4	38.1	6.3	19.8

Data sheets: [720005](#), 359 (35-800 A), 5785299 (100-2500 A)

# North American fuse links

## 250 V d.c. (UL) - 35 A to 800 A - FWX

### Time-current curve

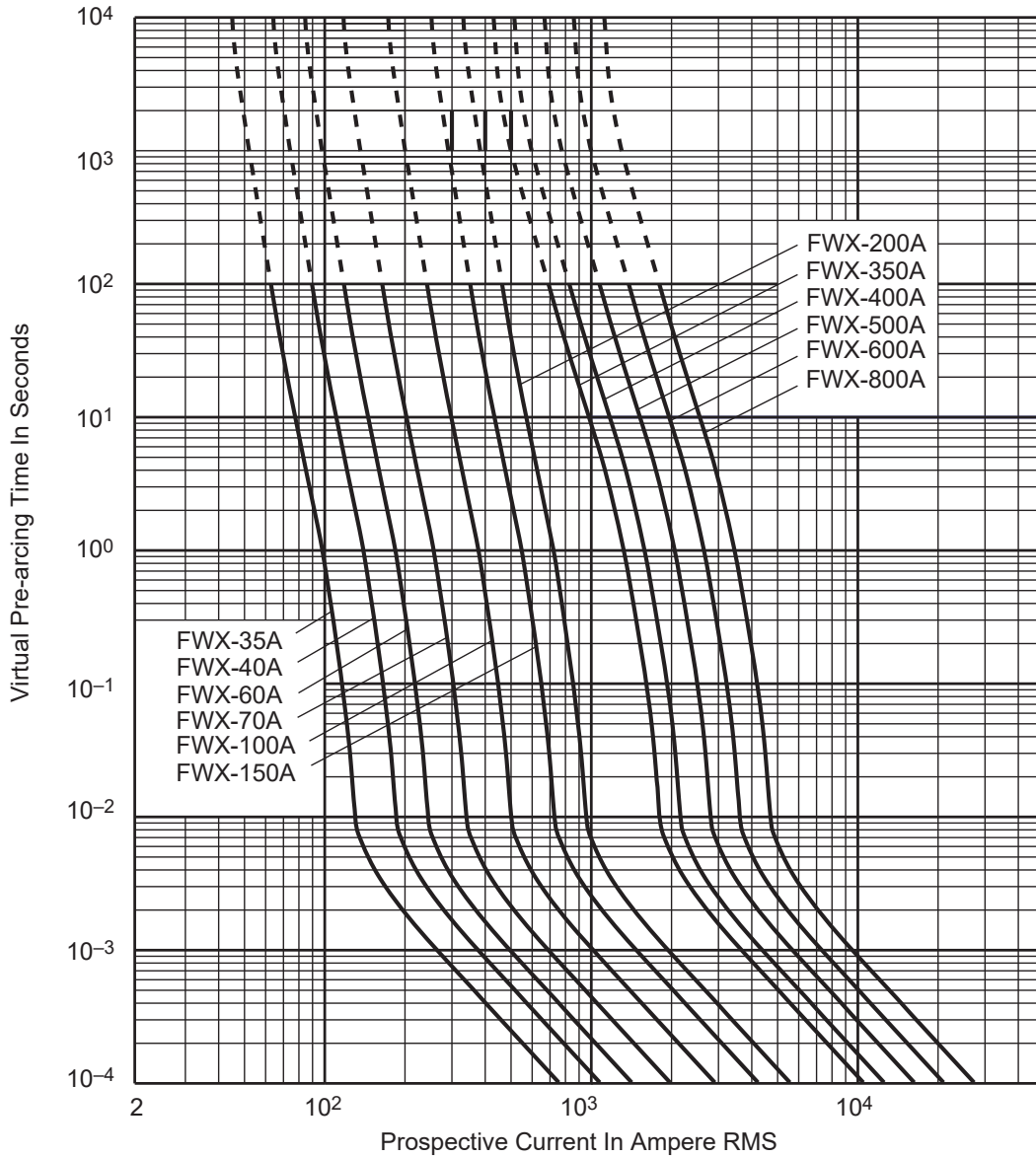

Contact [FUSETECH@eaton.com](mailto:FUSETECH@eaton.com) for the Time-current curves for the following ratings: 45, 50, 80, 90, 125, 175, 225, 250, 275, 300, 450 and 700 A

### Watts losses

Watts loss at rated current is given in the electrical characteristics. The curve allows the calculation of the watts losses at load currents lower than the rated current. The correction factor,  $K_p$ , is given as a function of the RMS load current,  $I_b$ , in percent of the rated current.

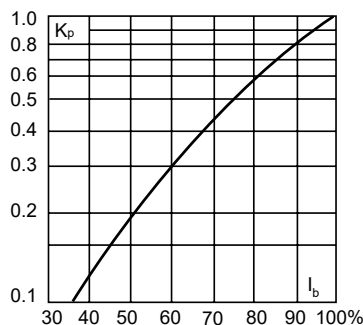

Data sheets: [720005](#), 359 (35-800 A), 5785299 (100-2500 A)

500 V d.c. (UL) - 50 A to 400 A - CHSF

Specifications

Description

North American style bolted tags high speed fuse links for the protection of DC common bus, DC drives, power converters/rectifiers and reduced rated voltage starters.

Technical Data

- Rated voltage: 500 V d.c. (UL)
- Rated current: 50 A to 400 A
- Breaking capacity: Maximum DC: 50 kA / Minimum DC 800%
- Conforms to IEC aR specifications for short-circuit protection



Standards / Agency information

UL Recognised, File E56412, guide JFHR2, CSA Component Acceptance, Class 1422-30, File 53787, IEC aR (self-certified), CE, RoHS compliant, REACH declaration available upon request

Catalog numbers

Rated voltage	Rated current (Amps)	I <sup>2</sup> t (A <sup>2</sup> Sec)			Catalog numbers
		Pre-arcing	DC clearing at 50 kA/500 V d.c.	Watts loss (W) at 80%	
500 V d.c.(UL)	50	304	935	3.8	CHSF-50
	60	438	1346	4.5	CHSF-60
	70	596	1833	5.3	CHSF-70
	80	778	2394	6.1	CHSF-80
	100	1216	3740	7.6	CHSF-100
	125	2042	6465	12	CHSF-125
	150	2941	9309	14.3	CHSF-150
	175	4003	12,671	16.7	CHSF-175
	200	5228	16,550	19.1	CHSF-200
	225	6835	21,278	26.1	CHSF-225
	250	8438	26,270	29	CHSF-250
	300	12151	37,828	34.8	CHSF-300
	350	16539	51,488	40.6	CHSF-350
	400	21603	67,250	46.4	CHSF-400

Dimensions (mm)

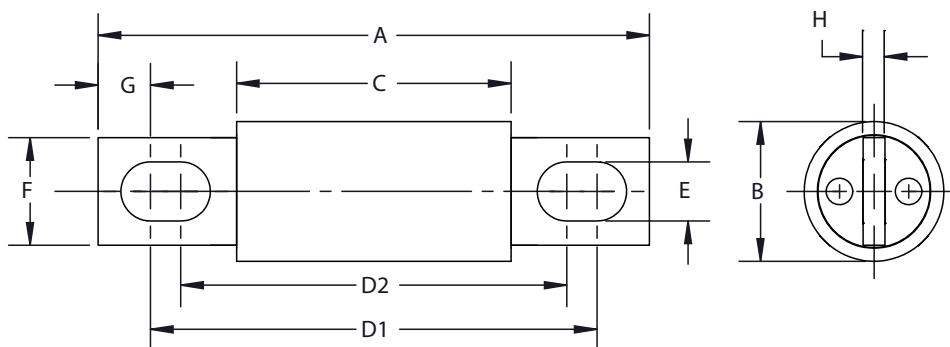

Amps	A	B	C	D1	D2	E	F	G	H
50-100	81	20	40	61	58	8.7	16	7.7	3.2
125-200	92	25	53	77	68	8.7	19	7.8	3.2
225-400	92	30	53	74	68	8.7	25	9	4.8

Data sheet: [10414](#)

# North American fuse links

## 500 V d.c. (UL) - 50 A to 400 A - CHSF

### Time-current curve

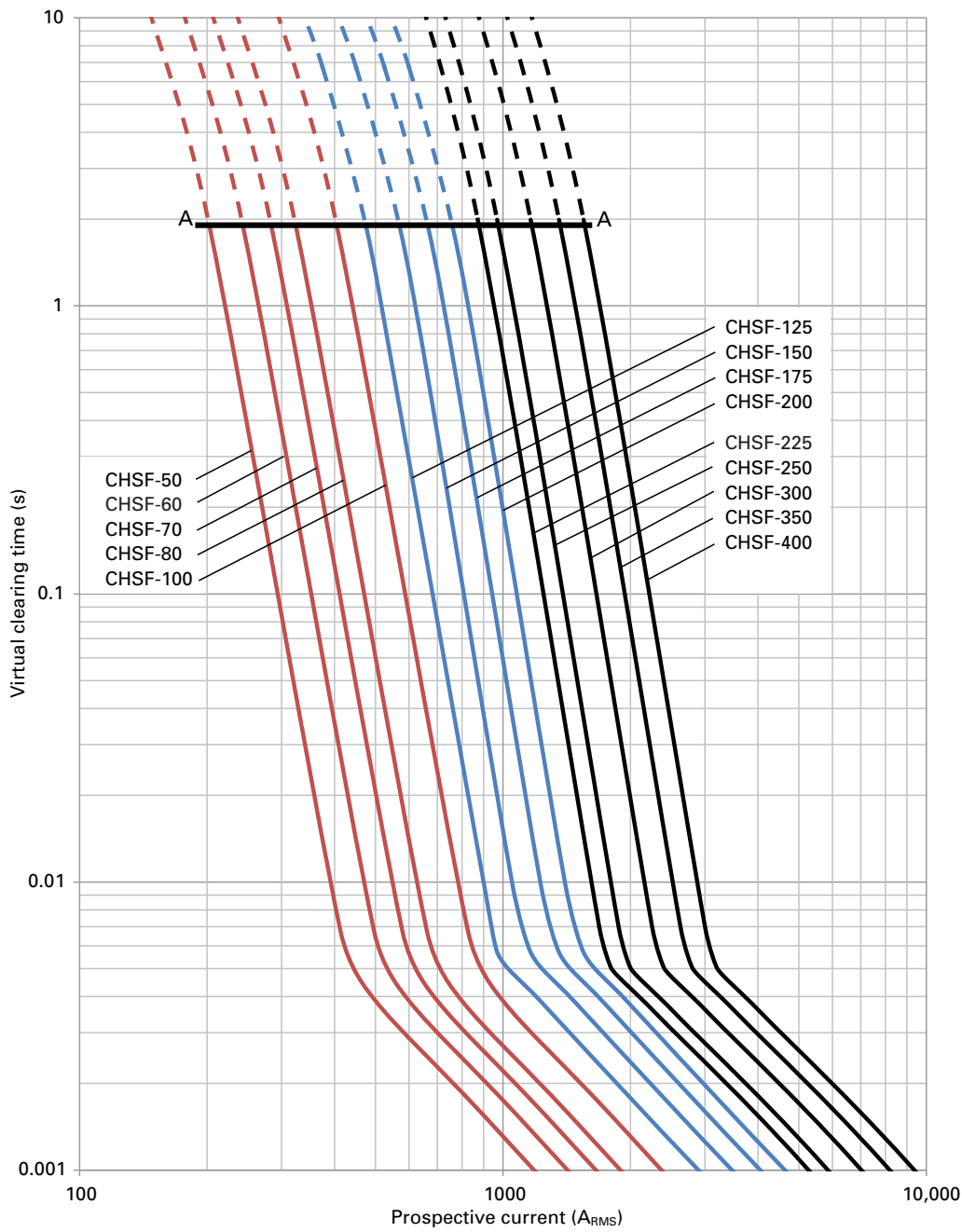

500 V d.c. (UL) - 50 A to 400 A - CHSF

DC Arc voltage

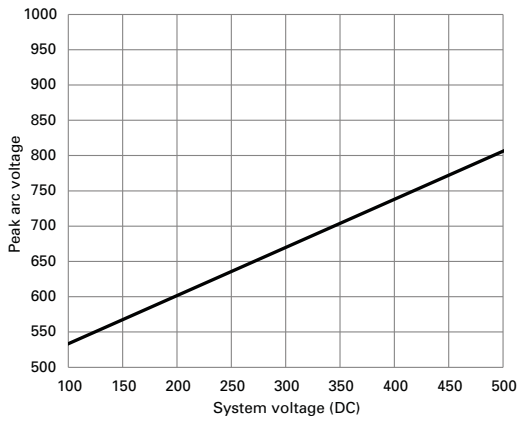

DC clearing I<sup>2</sup>t voltage correction factor

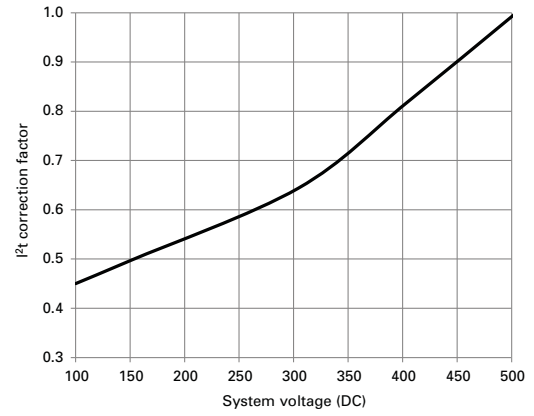

Temperature derating

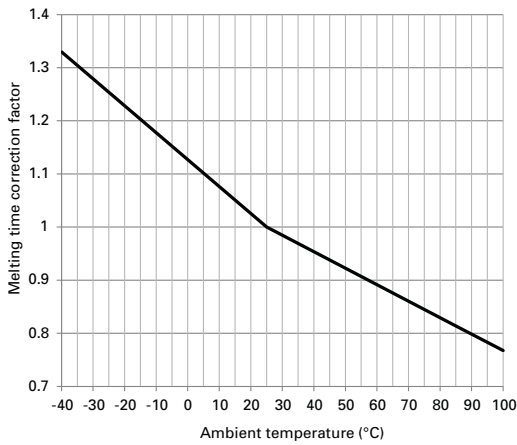

# North American fuse links

## 500 V d.c. (UL) - 35 A to 900 A - FWH

### Specifications

#### Description

North American style bolted tags high speed fuse links for the protection of DC common bus, DC drives, power converters/rectifiers and reduced rated voltage starters.

#### Technical data

- Rated voltage: 500 V d.c.
- Rated current: 35 A to 900 A
- Breaking capacity: 50 kA at 500 V d.c.

#### Standards / Agency information

CE, UL Recognition JFHR2.E91958 FWH-\_B (35 A to 200 A), JFHR2.E56412 FWH-\_A (225 A to 800 A), CSA Component Acceptance Class 1422-30, File 53787 (35 A to 1600 A)



### Catalog numbers

Rated voltage	Rated current (Amps)	$I^2t$ (A <sup>2</sup> Sec)		Catalog numbers
		Pre-arcing	Watts loss (W)	
500 V d.c. (UL)	35	34	8	FWH-35B
	40	76	7.5	FWH-40B
	45	105	7.5	FWH-45B
	50	135	7.5	FWH-50B
	60	210	9.9	FWH-60B
	70	210	10.6	FWH-70B
	80	305	12.7	FWH-80B
	90	360	15	FWH-90B
	100	475	17	FWH-100B
	125	800	25	FWH-125B
	150	1100	30	FWH-150B
	175	1450	35	FWH-175B
	200	1900	40	FWH-200B
	225	4600	39	FWH-225A
	250	6300	41	FWH-250A
	275	7900	46	FWH-275A
	300	9800	51	FWH-300A
	325	13,700	53	FWH-325A
	350	14,500	58	FWH-350A
	400	19,200	65	FWH-400A
450	24,700	74	FWH-450A	
500	29,200	84	FWH-500A	
600	41,300	108	FWH-600A	
700	55,000	120	FWH-700A	
800	76,200	129	FWH-800A	
900	74,000	132	FWH-900A	

Data sheets: [720007](#), 360 (350-800 A), 5785304 (35-200 A)

500 V d.c. (UL) - 35 A to 900 A - FWH

Dimensions (mm) - 35 A to 800 A

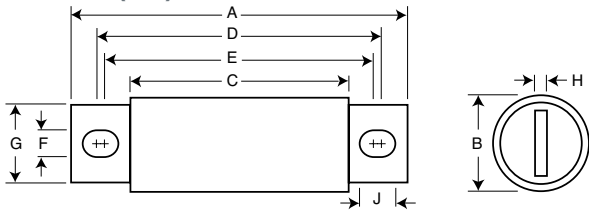

Dimensions (mm) - 900 A

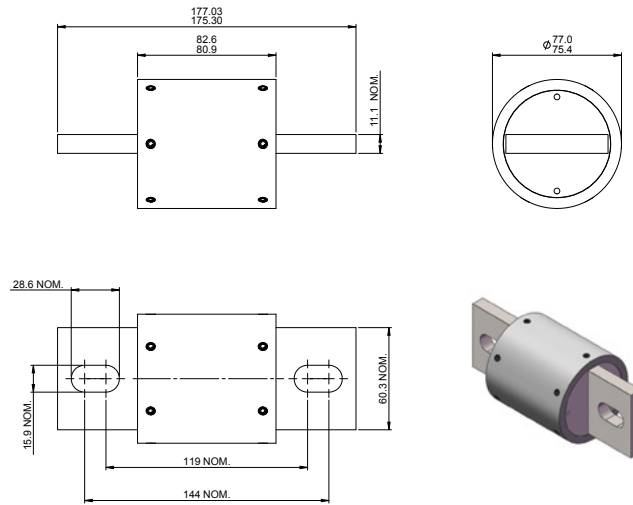

Amp range	A	B	C	D	E	F	G	H	J
35-60	81.0	20.6	40.4	64.5	55.6	8.6	18.3	3.3	13.2
70-100	91.9	24.1	44.2	72.4	71.4	8.9	19.1	3.3	9.7
125-200	91.9	29.5	46.7	73.4	70.4	8.6	25.4	4.8	10.4
225-400	110.2	38.1	53.1	87.4	69.9	10.4	25.4	6.4	19.1
450-600	110.2	50.8	53.1	89.7	70.6	10.4	38.1	6.4	19.8
700-800	161.0	63.5	53.1	126.2	87.4	13.5	50.8	9.7	33.0

Time-current curve - 35 A to 200 A and 900 A to 1600 A

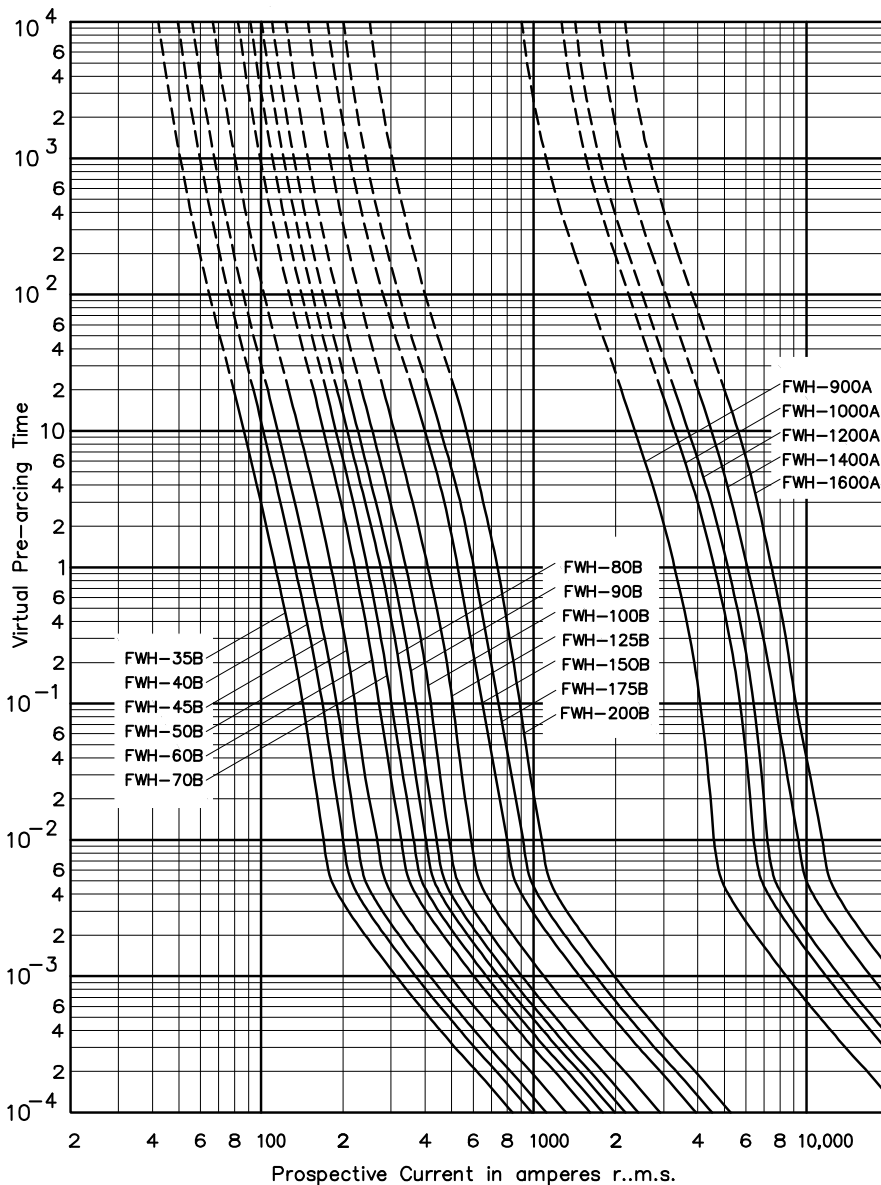

Data sheets: [720007](#), 360 (350-800 A), 5785304 (35-200 A)

# North American fuse links

## 500 V d.c. (UL) - 35 A to 900 A - FWH

### Time-current curve - 350 A to 800 A

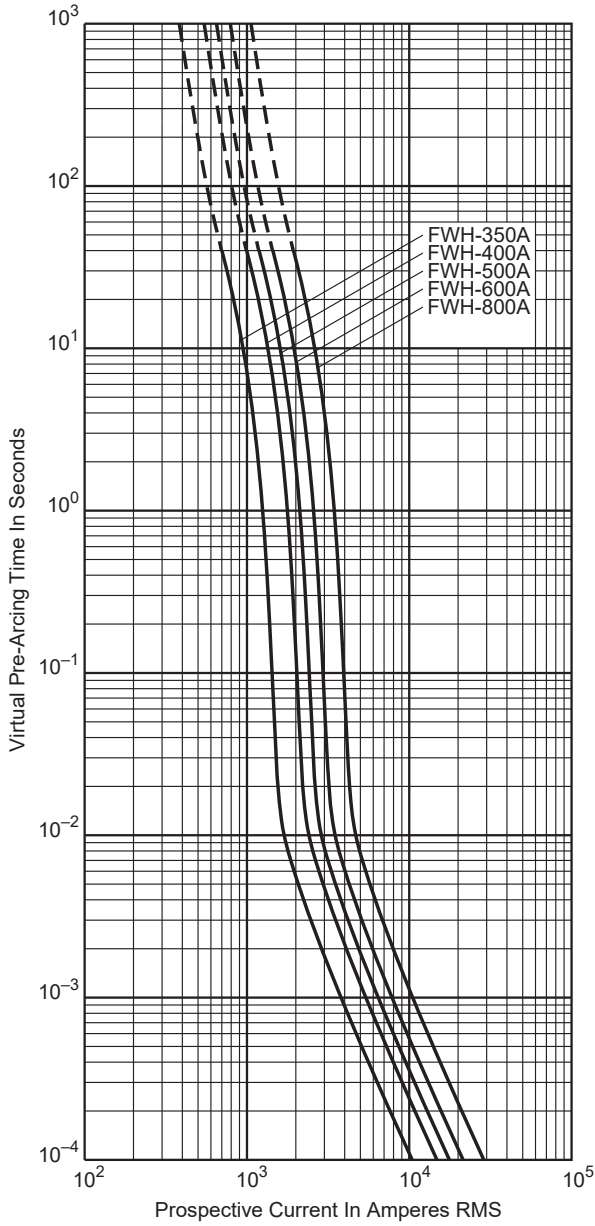

Contact [FUSETECH@eaton.com](mailto:FUSETECH@eaton.com) for the Time-current curves for the following ratings: 225 to 325 A, 450 A and 700 A

### Watts losses

Watts loss at rated current is given in the electrical characteristics. The curve allows the calculation of the watts losses at load currents lower than the rated current. The correction factor,  $K_p$ , is given as a function of the RMS load current,  $I_b$ , in percent of the rated current.

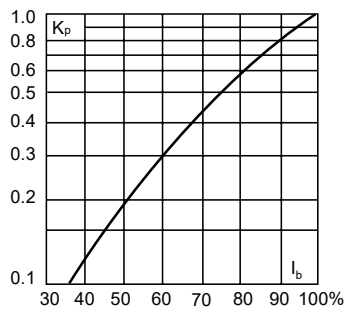

Data sheets: [720007](#), 360 (350-800 A), 5785304 (35-200 A)

## 700 V d.c.(UL) - 5 A to 800 A - FWP-B

### Specifications

#### Description

North American style bolted tags high speed fuse links for the protection of DC common bus, DC drives, power converters/rectifiers and reduced rated voltage starters.

#### Technical data

- Rated voltage: Up to 700 V d.c. (UL)
- Rated current: 5 A to 800 A
- Breaking capacity: see details in table below

#### Standards / Agency information

CE, UL Recognition JFHR2.E91958 FWP-\_B (5 A to 100 A, 700 A to 1200 A), JFHR2.E56412 FWP-\_A (125 A to 600 A) and CSA Component Acceptance file class 1422-30, (53787) on 5 A to 800 A



#### Catalog numbers

Rated voltage	Rated current (Amps)	Breaking capacity (kA)	I <sup>2</sup> t (A <sup>2</sup> Sec)		Catalog numbers
			Pre-arcing	Watts loss (W)	
500 V d.c. (10 ms)	5	50	1.6	1.5	FWP-5B
	10	50	3.6	4	FWP-10B
	15	50	10	5.5	FWP-15B
	20	50	26	6	FWP-20B
	25	50	44	7	FWP-25B
	30	50	58	9	FWP-30B
700 V d.c.	35	50	34	12	FWP-35D
	40	50	76	12	FWP-40D
	50	50	135	12	FWP-50D
	60	50	210	15.5	FWP-60D
	70	50	305	18	FWP-70B
	80	50	360	21	FWP-80B
	90	50	415	25	FWP-90B
	100	50	540	27	FWP-100B
	125	10	1800	28	FWP-125A
	150	10	2900	32	FWP-150A
	175	10	4200	35	FWP-175A
	200	10	5500	43	FWP-200A
	225	10	7700	45	FWP-225A
	250	10	10,500	48	FWP-250A
	300	10	17,600	58	FWP-300A
	350	10	23,700	65	FWP-350A
	400	10	31,000	78	FWP-400A
	450	50	36,400	94	FWP-450A
	500	50	45,200	107	FWP-500A
	600	50	66,700	122	FWP-600A
700	50	54,000	125	FWP-700A	
800	50	78,000	140	FWP-800A	

Data sheets: [720012](#), 5785316 (5-30 A), 361 (150-600 A), 5785308 (35-100 A, 700 to 800 A)

# North American fuse links

## 700 V d.c.(UL) - 5 A to 800 A - FWP-B

Time-current curve - 5 A to 30 A

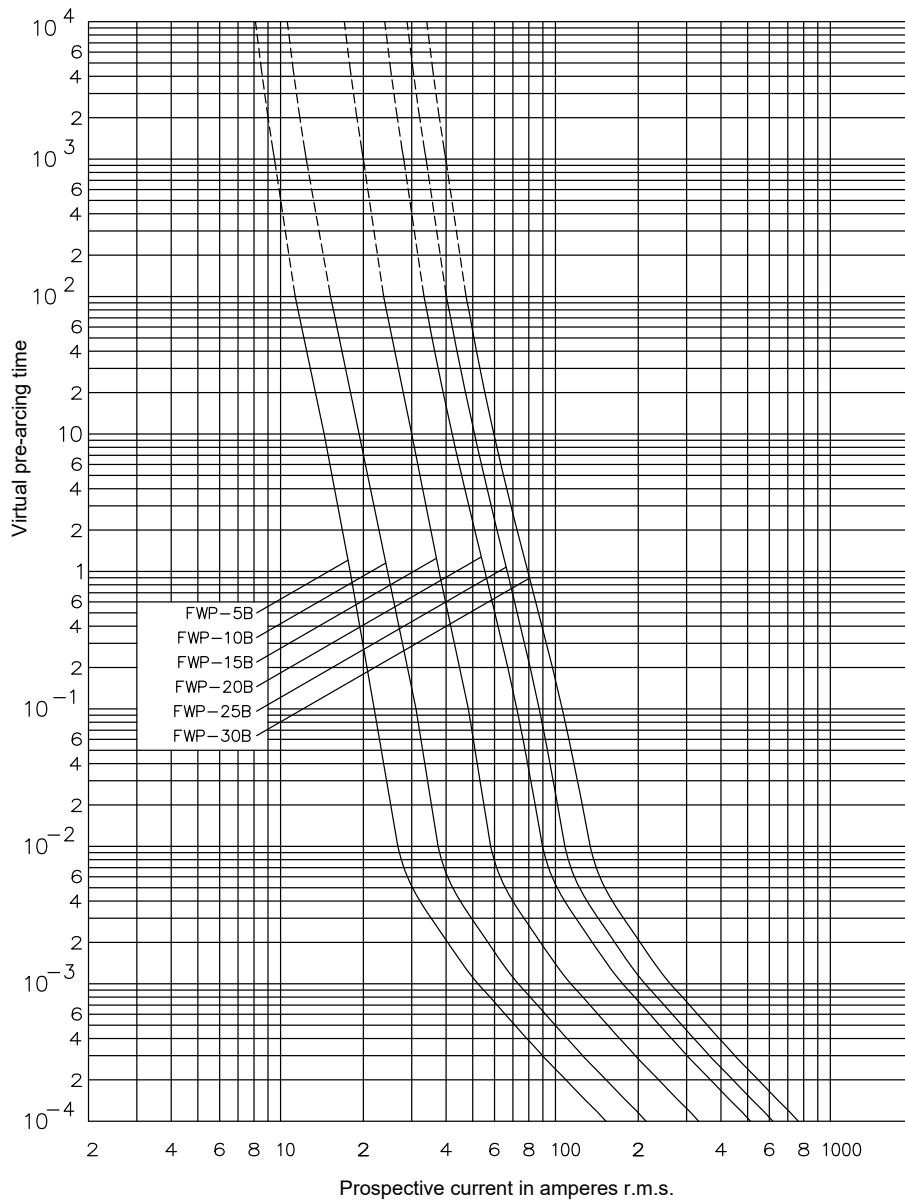

Data sheets: [720012](#), 5785316 (5-30 A), 361 (150-600 A), 5785308 (35-100 A, 700 to 800 A)

700 V d.c.(UL) - 5 A to 800 A - FWP-B

Time-current curve - 35 A to 800 A

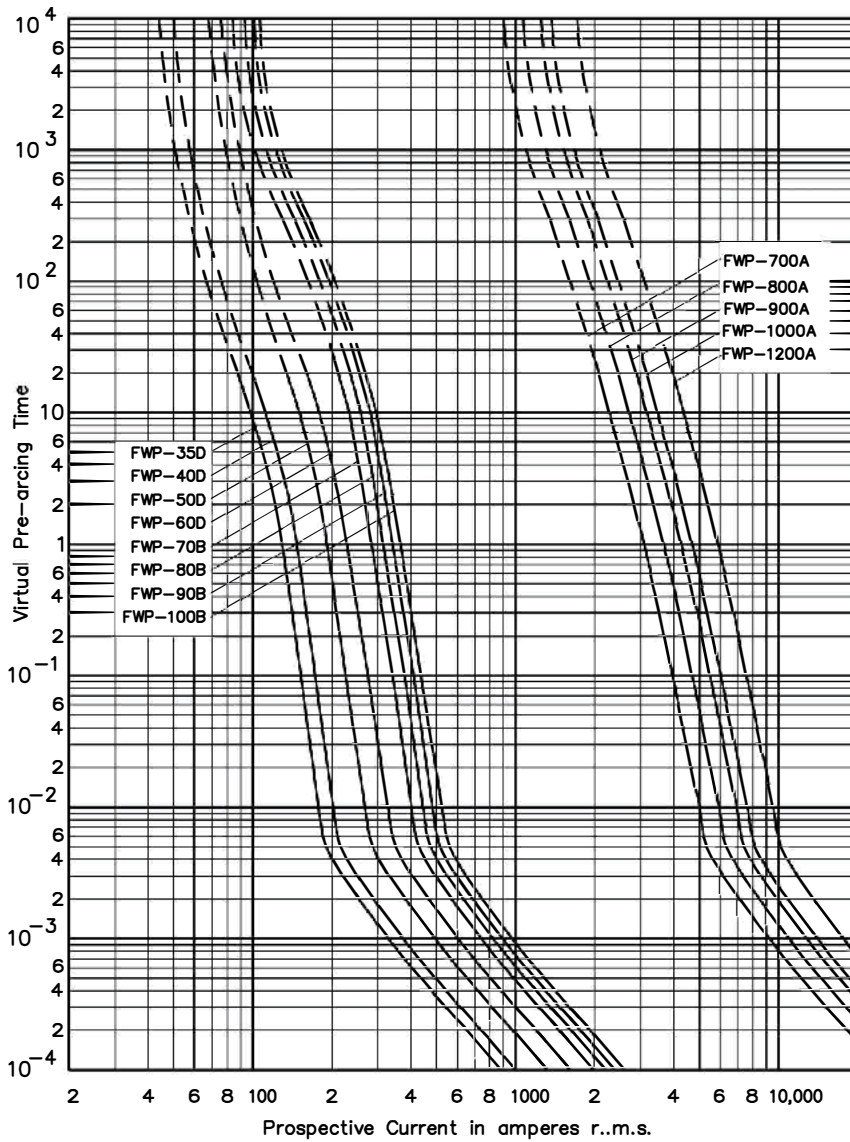

Contact [FUSETECH@eaton.com](mailto:FUSETECH@eaton.com) for the Time-current curves for the following ratings: 125 A to 600 A

**Watts losses**

Watts loss at rated current is given in the electrical characteristics. The curve allows the calculation of the watts losses at load currents lower than the rated current. The correction factor,  $K_p$ , is given as a function of the RMS load current,  $I_b$ , in percent of the rated current.

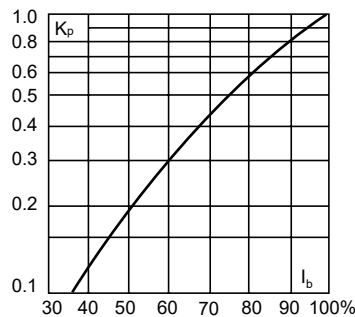

Data sheets: [720012](#), 5785316 (5-30 A), 361 (150-600 A), 5785308 (35-100 A, 700 to 800 A)

# North American fuse links

## 700 V d.c.(UL) - 5 A to 800 A - FWP-B

Cut-off curve - 5 A to 800 A

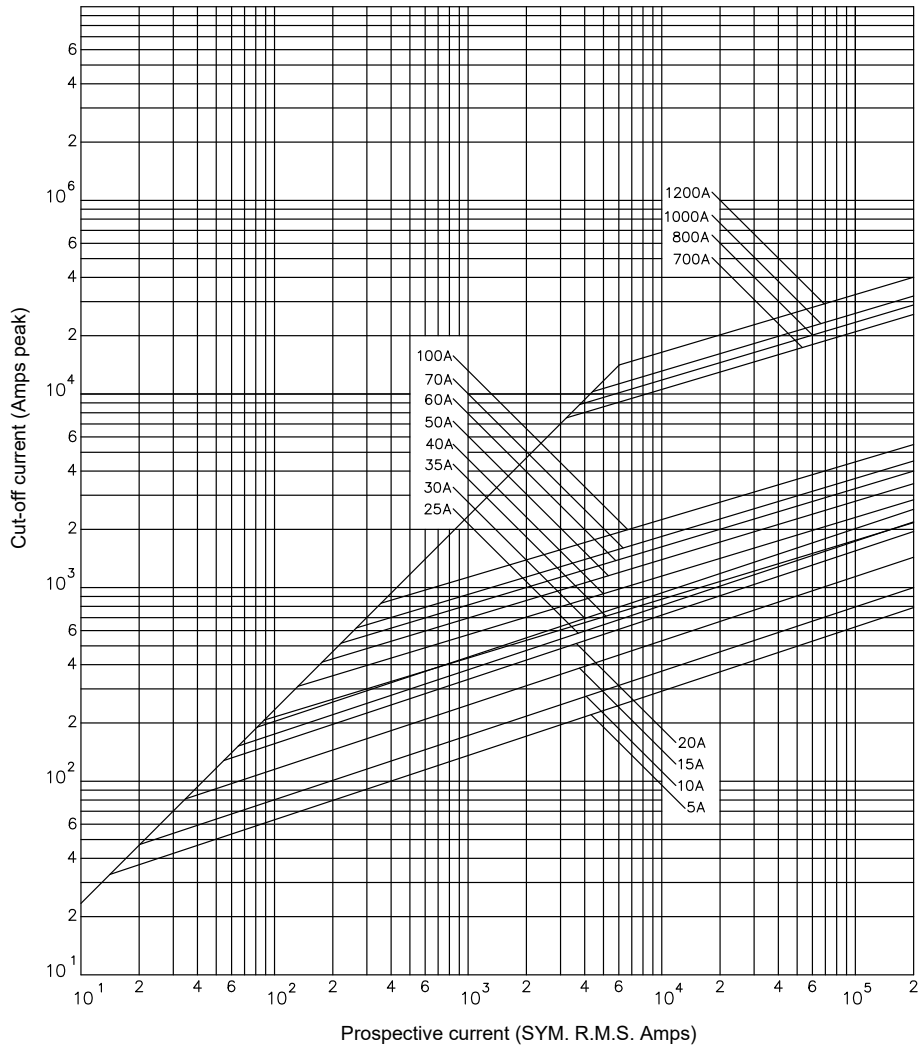

Data sheets: [720012](#), 5785316 (5-30 A), 361 (150-600 A), 5785308 (35-100 A, 700 to 800 A)

700 V d.c.(UL) - 5 A to 800 A - FWP-B

Dimensions (mm) - 5 A to 30 A

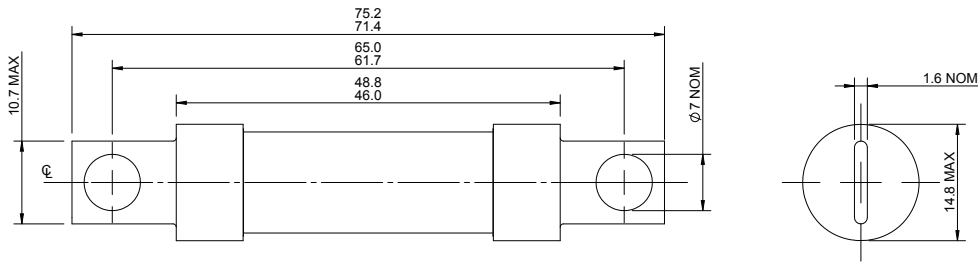

Dimensions (mm) - 35 A to 60 A

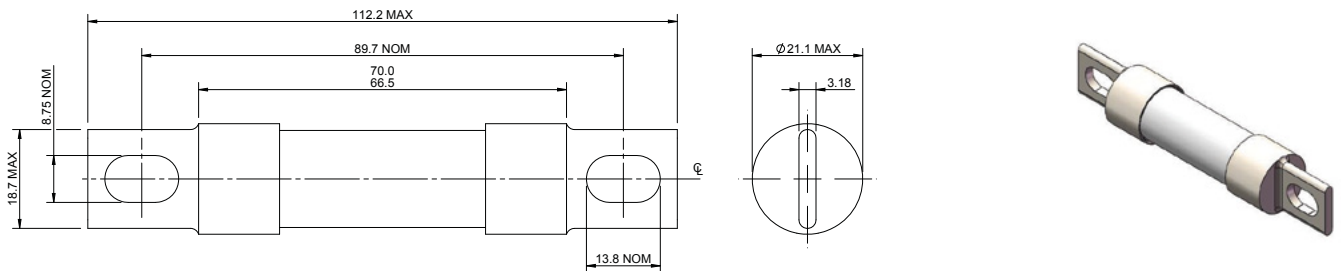

Dimensions (mm) - 70 A to 600 A

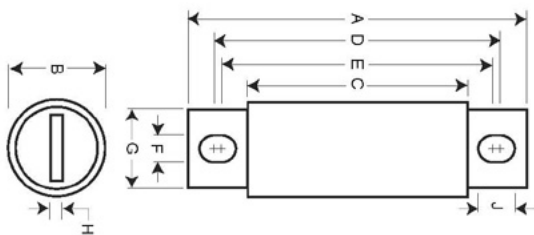

Amp range	A	B	C	D	E	F	G	H	J
70-100	112.0	24.1	65.8	92.2	90.4	8.6	19.1	3.3	9.7
125-200	129.3	38.1	72.1	106.4	88.9	10.4	25.4	6.4	19.1
225-400	129.3	50.8	72.1	108.7	89.7	10.4	38.1	6.4	19.8
450-600	180.1	63.5	72.1	145.3	106.4	13.5	50.8	9.7	33.0

Dimensions (mm) - 700 A and 800 A

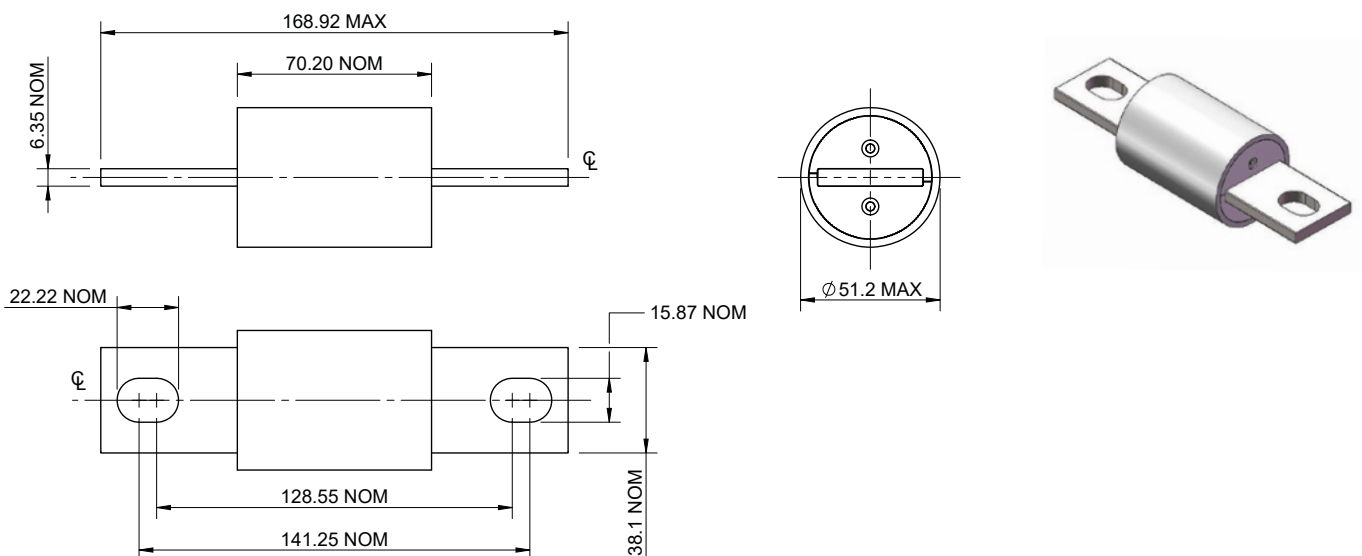

Data sheets: [720012](#), 5785316 (5-30 A), 361 (150-600 A), 5785308 (35-100 A, 700 to 800 A)

# North American fuse links

## 1000 V d.c. (IEC/UL) - 70 A to 600 A - FWE

### Specifications

#### Description

North American style bolted tags high speed fuse links designed for the protection of DC charging stations, specialist vehicle onboard applications and general DC power conversion equipment and battery systems.

#### Technical data

- Rated voltage: 1000 V d.c. (IEC/UL)
- Rated current: 70 A to 600 A
- Breaking capacity: 100 kA
- Operating class: aR



#### Standards / Agency information

CE, IEC 60269-4 and UL 248-13 Recognised

#### Catalog numbers

Rated voltage	Rated current (Amps)	Breaking capacity (kA)	Watts loss (50% rated current)	Watts loss (100% rated current)	Pre-arcing I <sup>2</sup> t (A <sup>2</sup> Sec)	Clearing I <sup>2</sup> t	Catalog number
1000 V d.c. (IEC/UL)	70	100	3.8	21	680	5060	FWE-70A
	80	100	4.2	24	1020	7240	FWE-80A
	90	100	4.6	27	1400	9400	FWE-90A
	100	100	5	30	1820	12,300	FWE-100A
	125	100	6	43	1830	8400	FWE-125A
	150	100	7	49	2670	12,900	FWE-150A
	175	100	8	52	4670	22,300	FWE-175A
	200	100	9	56	6900	31,600	FWE-200A
	225	100	10	69	7880	34,600	FWE-225A
	250	100	11	79	9940	46,700	FWE-250A
	275	100	12	83	13,000	57,000	FWE-275A
	300	100	13	87	16,800	73,900	FWE-300A
	350	100	15	100	21,100	132,000	FWE-350A
	400	100	16	110	31,500	186,000	FWE-400A
	450	100	19	139	35,300	161,000	FWE-450A
	500	100	21	155	49,300	197,000	FWE-500A
550	100	23	167	58,600	312,000	FWE-550A	
600	100	25	180	74,700	335,000	FWE-600A	

#### Dimensions (mm)

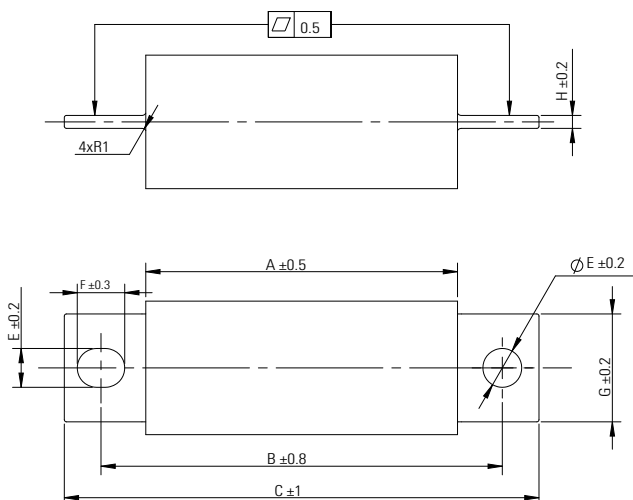

Catalog number	A	B	C	D	E	F	G	H
70A to 100A	72.2	93	110	25.4	9	11	19	2.2
125A to 200A	72.2	93	110	31	9	11	25	3
225A to 300A	72.2	100	122	38.1	11	13	28	3.5
350A to 400A	72.2	100	122	50.8	11	13	28	5
450A to 600A	72.2	100	122	63.5	11	13	40	6

1000 V d.c. (IEC/UL) - 70 A to 600 A - FWE

Time-current curve - 70 A to 100 A

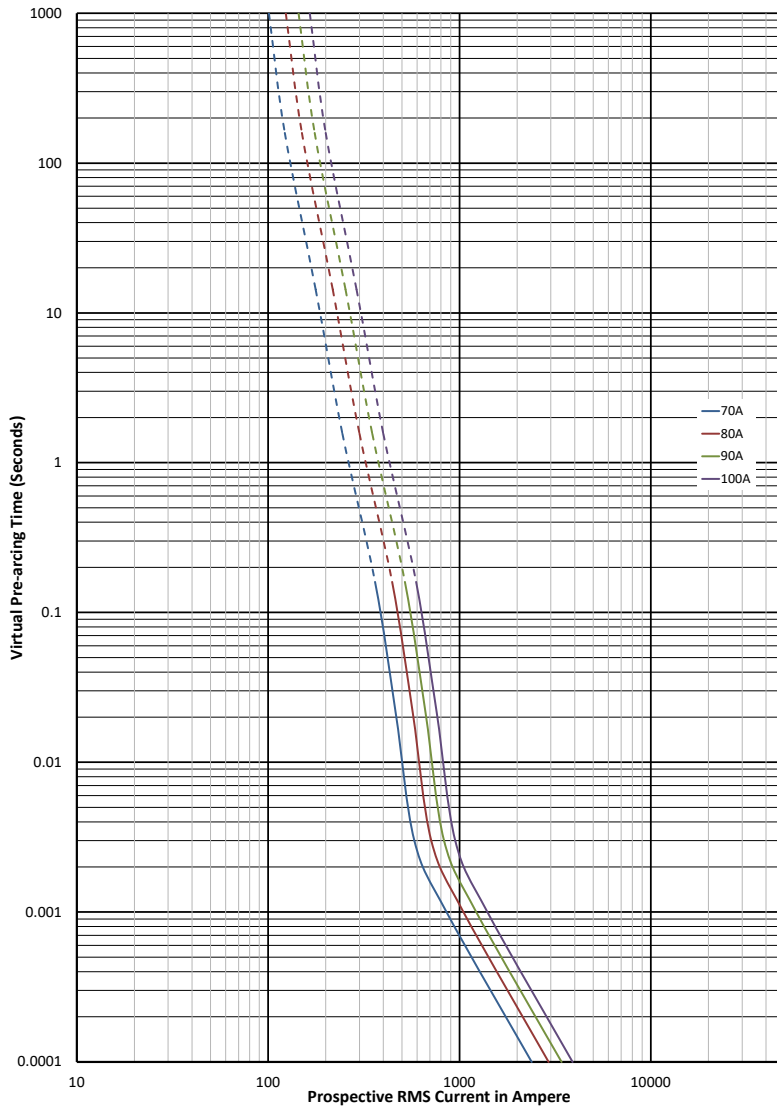

$K_b = 0.8$

**Total clearing  $I^2t$**

The total clearing  $I^2t$  at rated voltage and tested DC time constant are given in electrical characteristics. For other voltages the clearing  $I^2t$  is found by multiplying by correction factor,  $K$ , given as a function of applied working voltages,  $E_g$ .

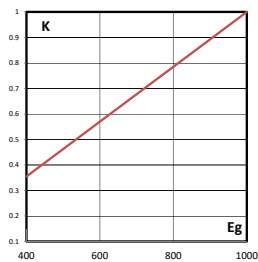

**Arc voltage**

This curve gives the peak arc voltage,  $U_l$ , which may appear across the fuse during its operation as a function of the applied working voltage,  $E_g$ , at a time constant of 10ms.

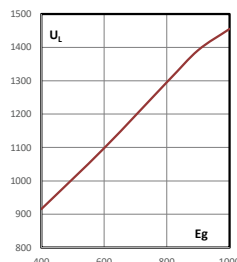

**Watts losses**

Watts loss at rated current is given in the electrical characteristics. The curve allows the calculation of the watts losses at load currents lower than the rated current. The correction factor,  $K_p$ , is given as a function of the RMS load current,  $I_b$ , in percent of the rated current.

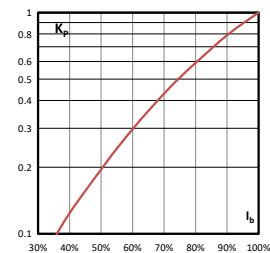

Data sheet: [TD135012EN](#)

## 1000 V d.c. (IEC/UL) - 70 A to 600 A - FWE

### Time-current curve - 125 A to 200 A

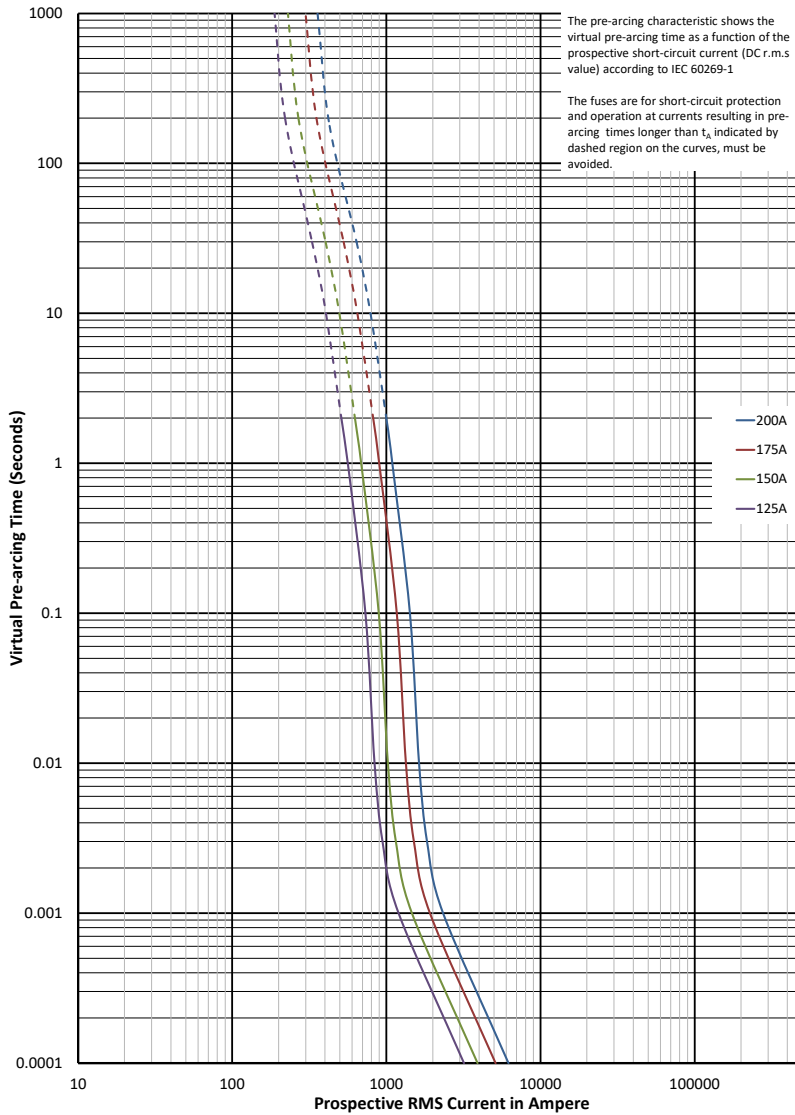

$K_b = 0.8$

### Total clearing $I^2t$

The total clearing  $I^2t$  at rated voltage and tested DC time constant are given in electrical characteristics. For other voltages the clearing  $I^2t$  is found by multiplying by correction factor,  $K$ , given as a function of applied working voltages,  $E_g$ .

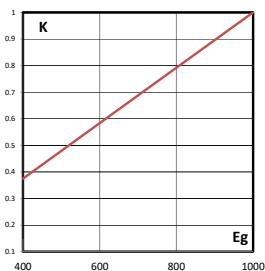

### Arc voltage

This curve gives the peak arc voltage,  $U_L$ , which may appear across the fuse during its operation as a function of the applied working voltage,  $E_g$ , at a time constant of 10ms.

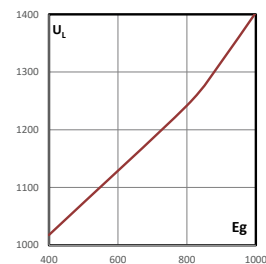

### Watts losses

Watts loss at rated current is given in the electrical characteristics. The curve allows the calculation of the watts losses at load currents lower than the rated current. The correction factor,  $K_p$ , is given as a function of the RMS load current,  $I_b$ , in percent of the rated current.

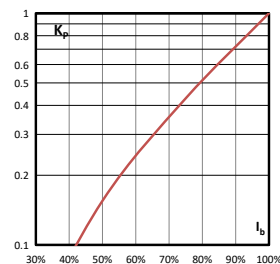

Data sheet: [TD135012EN](#)

1000 V d.c. (IEC/UL) - 70 A to 600 A - FWE

Time-current curve - 225 A to 300 A

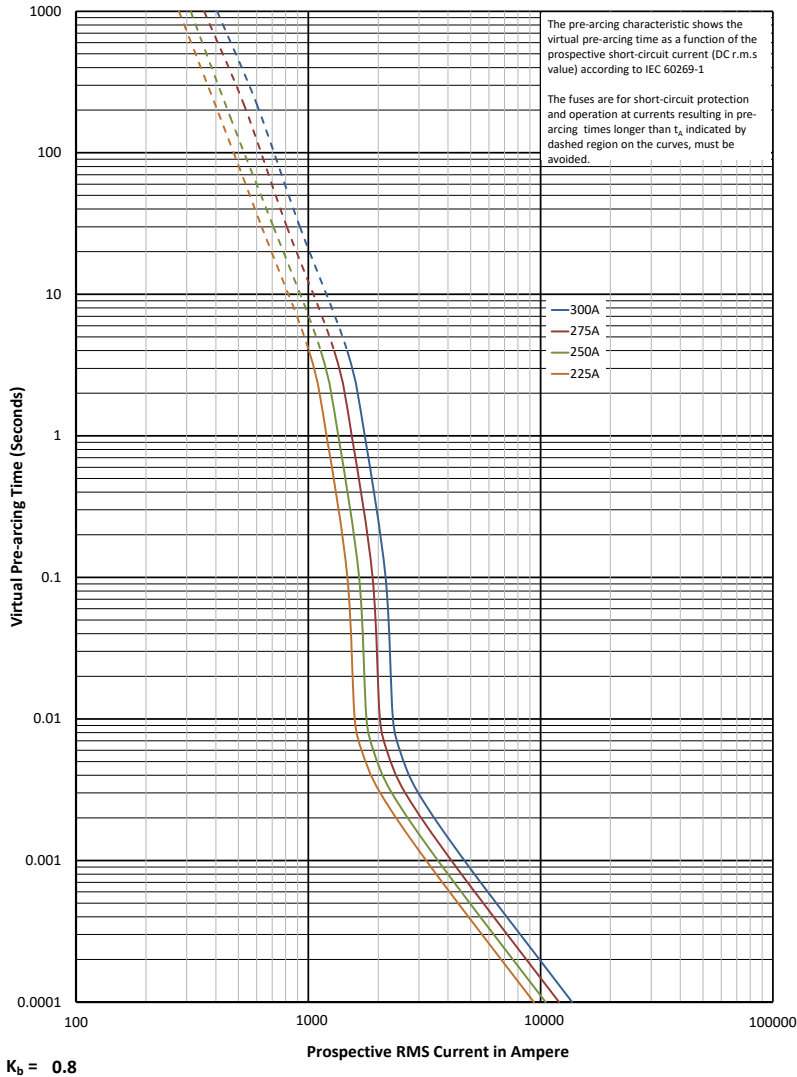

**Total clearing  $I^2t$**

The total clearing  $I^2t$  at rated voltage and tested DC time constant are given in electrical characteristics. For other voltages the clearing  $I^2t$  is found by multiplying by correction factor,  $K$ , given as a function of applied working voltages,  $E_g$ .

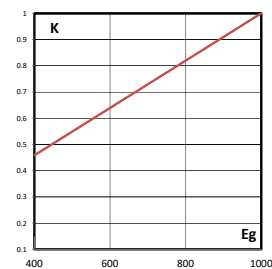

**Arc voltage**

This curve gives the peak arc voltage,  $U_L$ , which may appear across the fuse during its operation as a function of the applied working voltage,  $E_g$ , at a time constant of 10ms.

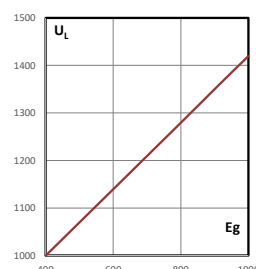

**Watts losses**

Watts loss at rated current is given in the electrical characteristics. The curve allows the calculation of the watts losses at load currents lower than the rated current. The correction factor,  $K_p$ , is given as a function of the RMS load current,  $I_b$ , in percent of the rated current.

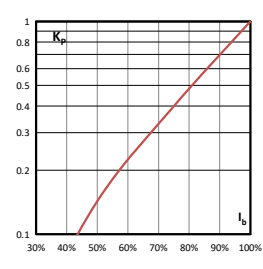

Data sheet: [TD135012EN](#)

# North American fuse links

## 1000 V d.c. (IEC/UL) - 70 A to 600 A - FWE

### Time-current curve - 350 A and 400 A

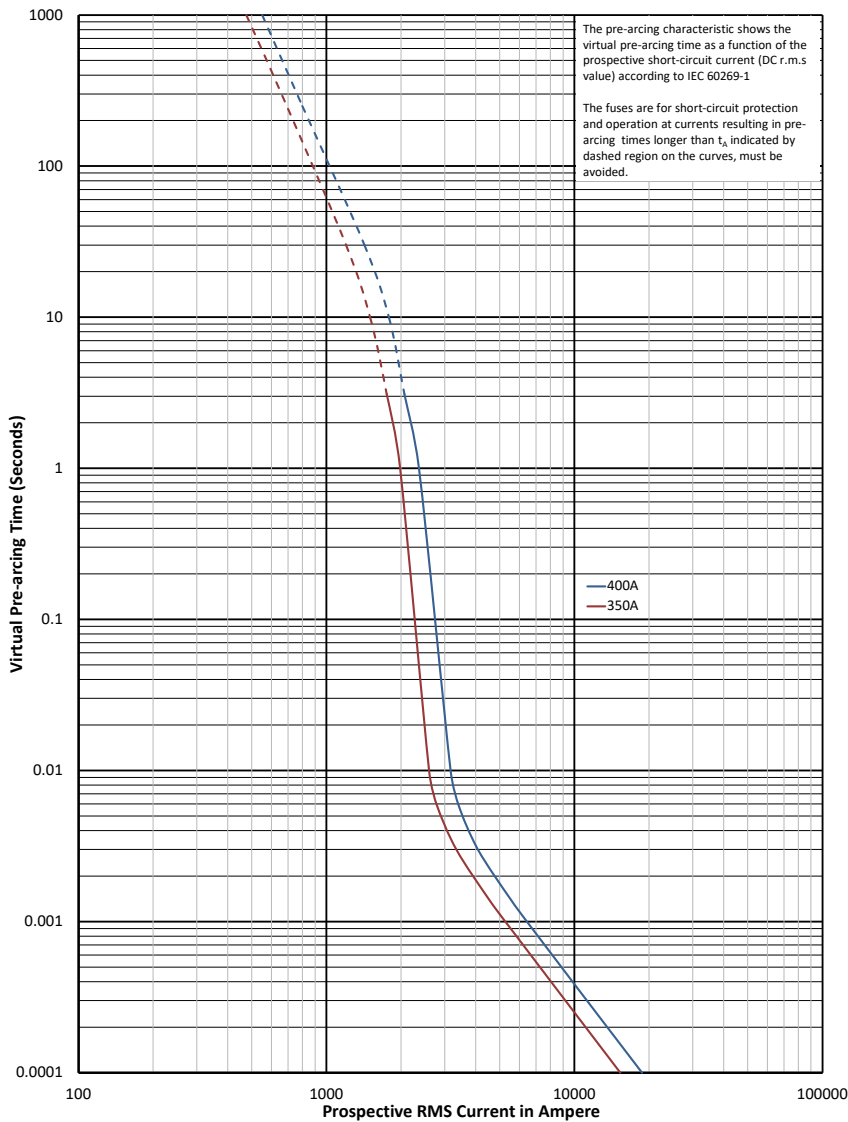

$K_b = 0.8$

### Total clearing $I^2t$

The total clearing  $I^2t$  at rated voltage and tested DC time constant are given in electrical characteristics. For other voltages the clearing  $I^2t$  is found by multiplying by correction factor,  $K$ , given as a function of applied working voltages,  $E_g$ .

### Arc voltage

This curve gives the peak arc voltage,  $U_L$ , which may appear across the fuse during its operation as a function of the applied working voltage,  $E_g$ , at a time constant of 10ms.

### Watts losses

Watts loss at rated current is given in the electrical characteristics. The curve allows the calculation of the watts losses at load currents lower than the rated current. The correction factor,  $K_p$ , is given as a function of the RMS load current,  $I_b$ , in percent of the rated current.

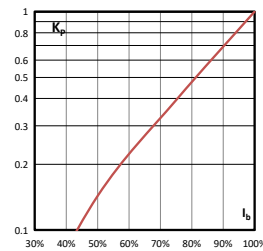
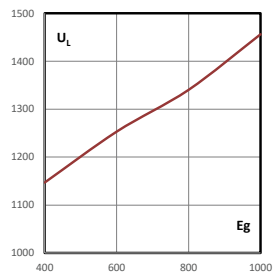
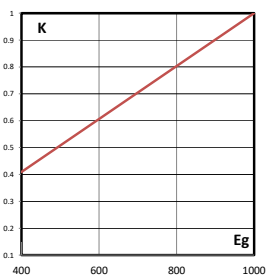

Data sheet: [TD135012EN](#)

1000 V d.c. (IEC/UL) - 70 A to 600 A - FWE

Time-current curve - 450 A to 600 A

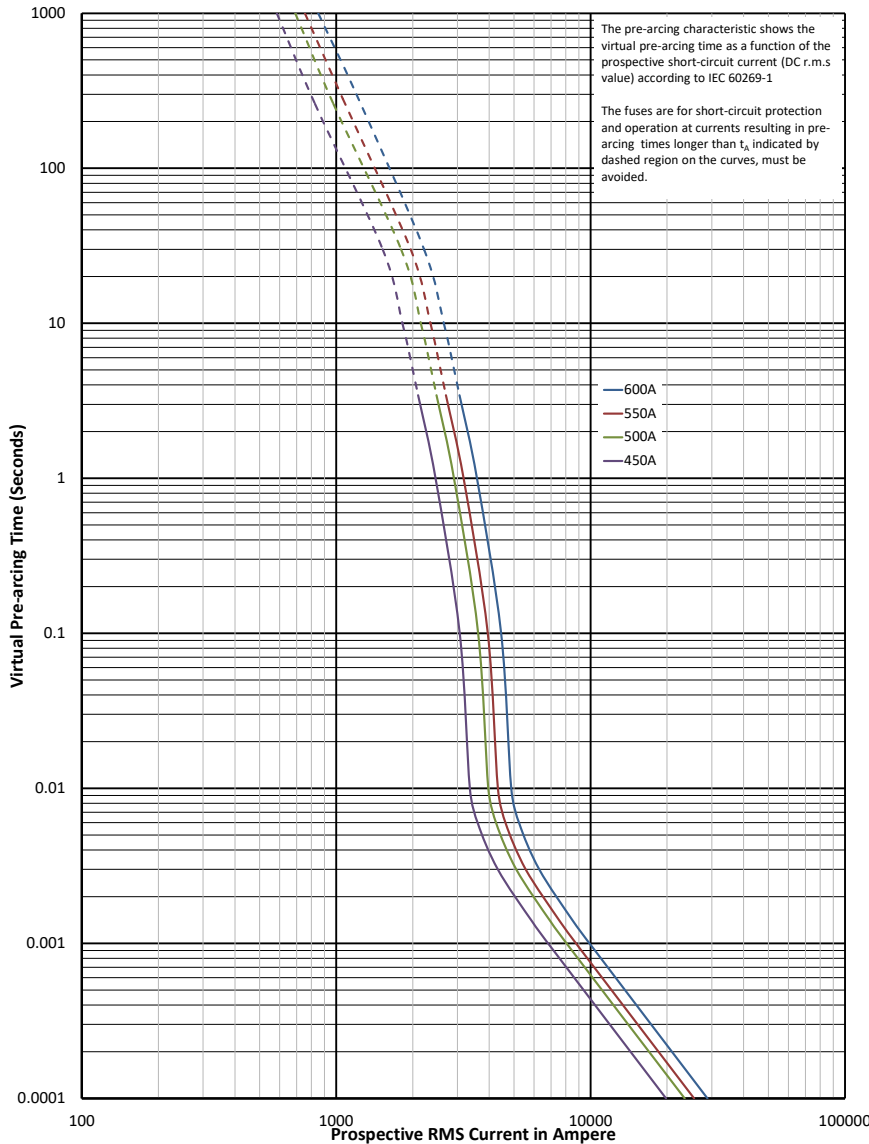

$K_b = 0.8$

**Total clearing  $I^2t$**

The total clearing  $I^2t$  at rated voltage and tested DC time constant are given in electrical characteristics. For other voltages the clearing  $I^2t$  is found by multiplying by correction factor,  $K$ , given as a function of applied working voltages,  $E_g$ .

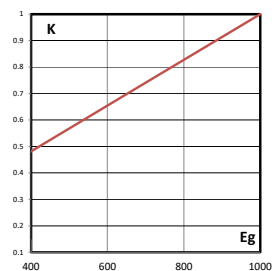

**Arc voltage**

This curve gives the peak arc voltage,  $U_L$ , which may appear across the fuse during its operation as a function of the applied working voltage,  $E_g$ , at a time constant of 10ms.

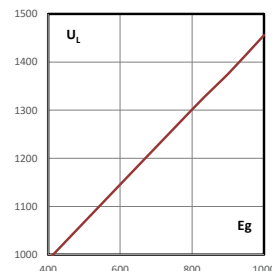

**Watts losses**

Watts loss at rated current is given in the electrical characteristics. The curve allows the calculation of the watts losses at load currents lower than the rated current. The correction factor,  $K_p$ , is given as a function of the RMS load current,  $I_b$ , in percent of the rated current.

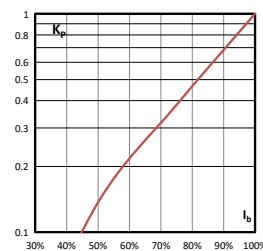

Data sheet: [TD135012EN](#)

# British standard BS88 fuse links

## 500 V d.c. (IEC), 700 V d.c. (UL) - 35 A to 200 A - FE, EET, FEE

### Specifications

#### Description

BS88 Style bolted tags high speed fuse links for the protection of DC common bus, DC drives, power converters / rectifiers and reduced rated voltage starters.

#### Technical data

- Rated voltage: 500 V d.c. (IEC and UL)
- Rated current: 35 A to 200 A
- Breaking capacity: EET, FE and FEE: 50 kA at 500 V d.c.
- Operating Class: aR

#### Compatible trip indicator

- EC600 (Indicator + clip)
- TI250 (indicator only)

#### Standards / Agency information

CE, designed and tested to BS88 part 4, IEC 60269 Part 4, Consult Eaton for specific UL Recognition status. CCC for ET, FE, EET, FEE.



### Catalog numbers

Fuse link type	Rated voltage	Rated current (Amps)	I <sup>2</sup> t (A <sup>2</sup> Sec)		Watts loss (W)	Catalog numbers
			Pre-arcing			
FE	500 V d.c. (IEC)/(UL)	35	33	9	35FE	
		40	52	9	40FE	
		45	76	11	45FE	
		50	103	11	50FE	
		63	135	12	63FE	
		71	210	17	71FE	
		80	250	20	80FE	
		90	360	20	90FE	
		100	470	23	100FE	
EET	500 V d.c. (IEC)/700 V d.c. (UL)	90	490	19	90EET	
		110	600	27	110EET	
		140	1050	35	140EET	
		160	1500	39	160EET	
FEE	500 V d.c. (IEC)/(UL)	100	400	24	100FEE	
		120	540	32	120FEE	
		140	850	36	140FEE	
		160	1000	46	160FEE	
		180	1400	46	180FEE	
		200	1900	52	200FEE	

Data sheets: [720024](#),5785314 (FE), 5785313 (EET), 5785292 (FEE)

500 V d.c. (IEC), 700 V d.c. (UL) - 35 A to 200 A - FE, EET, FEE

Dimensions (mm) - FE 35 A to 50 A

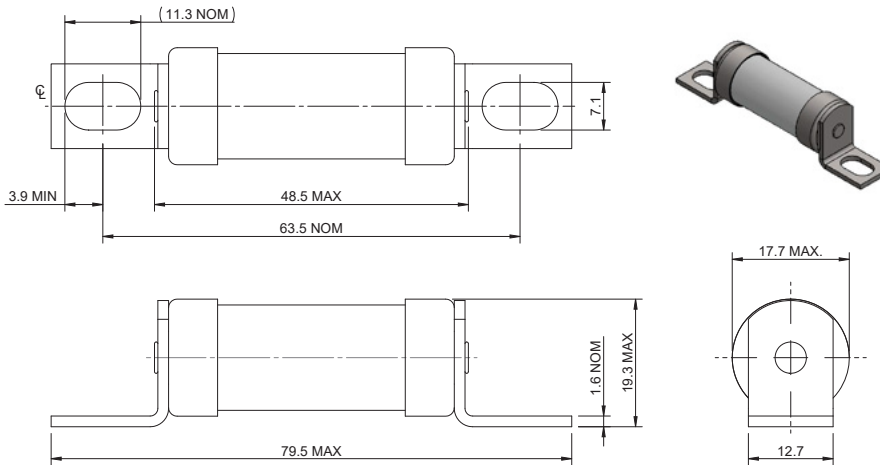

Indicator (optional)

Dimensions (mm) - FE 63 A to 100 A

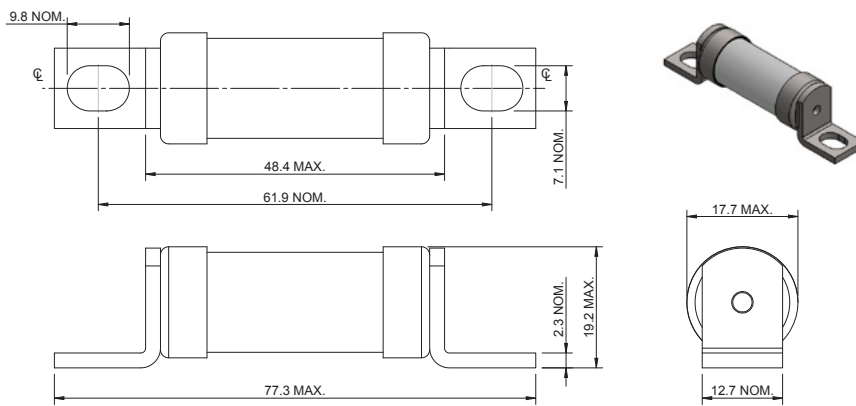

Dimensions (mm) - EET and FEE

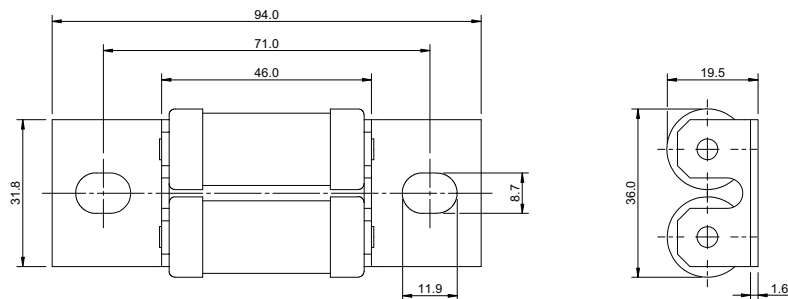

Data sheets: [720024](#), 5785314 (FE), 5785313 (EET), 5785292 (FEE)

# British standard BS88 fuse links

## 500 V d.c. (IEC), 700 V d.c. (UL) - 35 A to 200 A - FE, EET, FEE

Time-current curve - FE, 35 A to 100 A

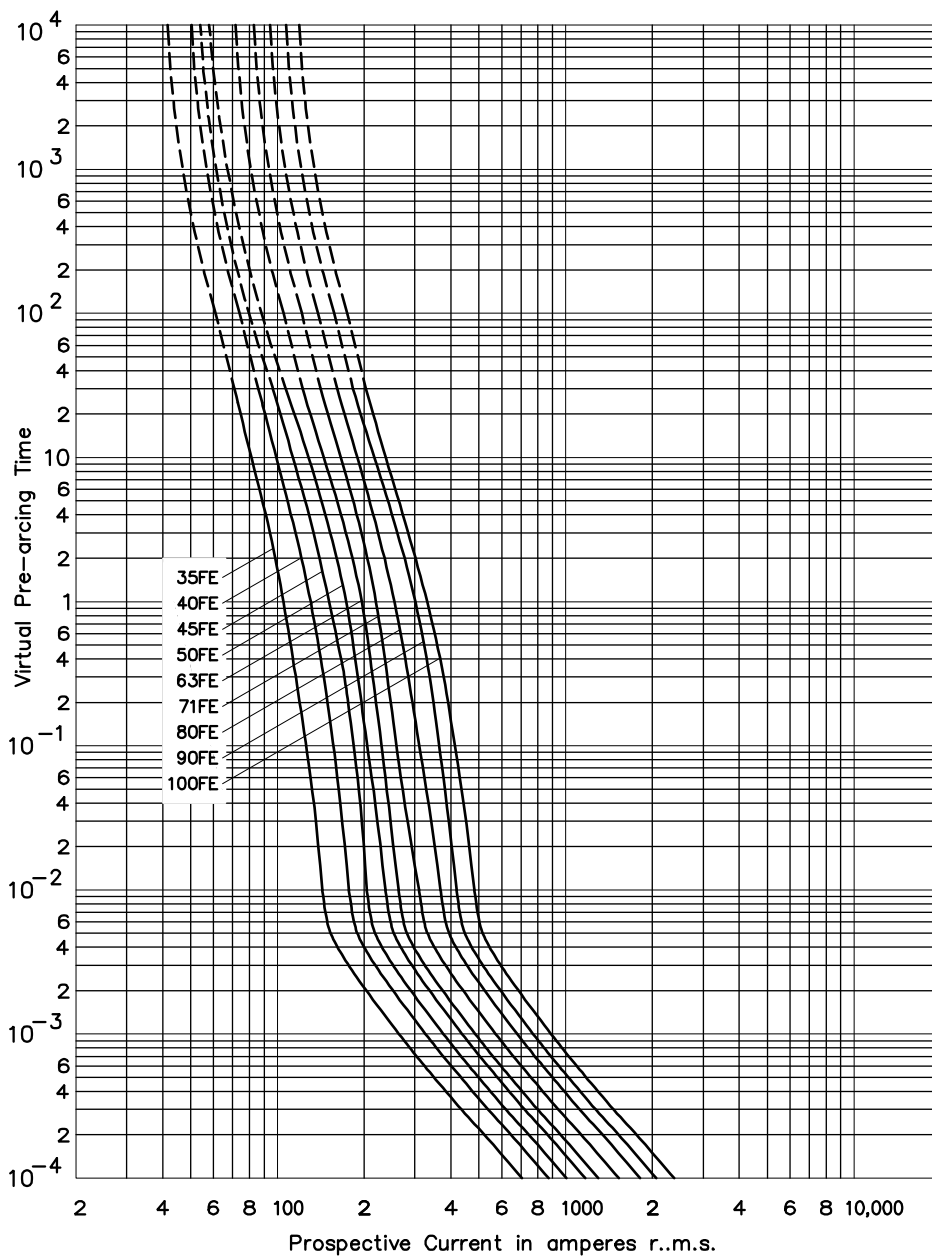

Data sheets: [720024](#), 5785314 (FE), 5785313 (EET), 5785292 (FEE)

500 V d.c. (IEC), 700 V d.c. (UL) - 35 A to 200 A - FE, EET, FEE

Time-current curve - EET, 90 A to 160 A

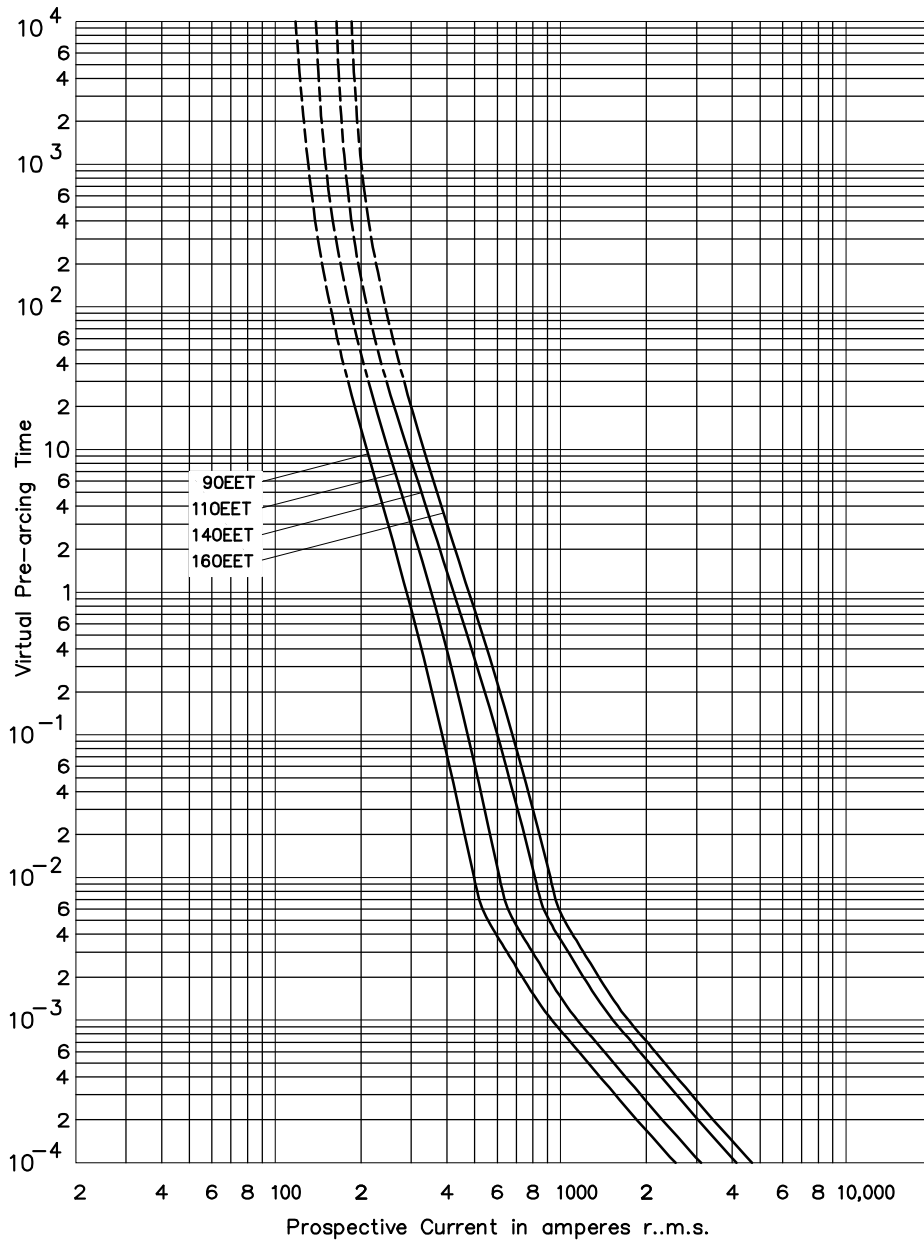

Data sheets: [720024](#), 5785314 (FE), 5785313 (EET), 5785292 (FEE)

# British standard BS88 fuse links

## 500 V d.c. (IEC), 700 V d.c. (UL) - 35 A to 200 A - FE, EET, FEE

Time-current curve - FEE, 100 A to 200 A

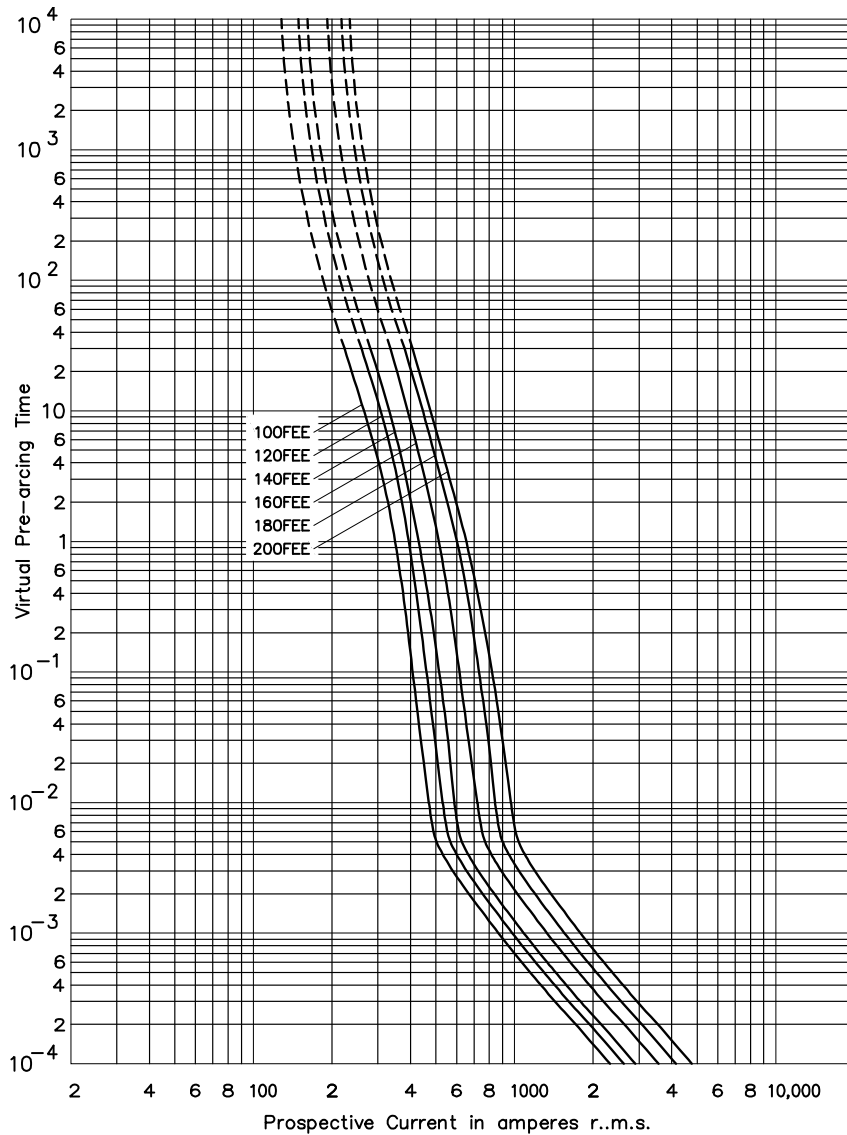

### Watts losses

Watts loss at rated current is given in the electrical characteristics. The curve allows the calculation of the watts losses at load currents lower than the rated current. The correction factor,  $K_p$ , is given as a function of the RMS load current,  $I_b$ , in percent of the rated current.

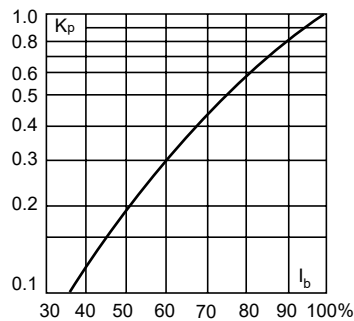

Data sheets: [Z20024](#), 5785314 (FE), 5785313 (EET), 5785292 (FEE)

## 250 V d.c. (IEC/UL) - 80 A to 315 A - BSF-DD25

### Specifications

#### Description

Eaton's Bussmann series BSF-DD25 centre bolted tags 250 V d.c. fuse links are specifically designed to protect battery modules and DC rated systems, offering reliable cable protection and effective coordination with backup devices.

#### Technical data

- Rated voltage: 250 V d.c. (IEC/UL)
- Rated current: 80 A to 315 A
- Breaking capacity: 100 kA
- Time constant: 10ms and 3ms tested (suitable for most DC applications)
- Operating Class: gR and gBAT

#### Standards / Agency information

Designed and tested to IEC 60269 Part 4 and part 7, CE Compliant, UL248-13 Recognised, ROHS Compliant



### Catalog numbers

Fuse link type	Rated voltage	Rated current (Amps)	Minimum Pre-arcing I <sup>2</sup> t A <sup>2</sup> Sec	Clearing I <sup>2</sup> t at 250 V d.c. 100 kA 100 ms L/R	Watts loss (W)	Catalog numbers
BSF-DD25	250 V d.c. (IEC/UL)	80	7200	18,000	8	BSF-080A-DD25
		100	20,000	48,000	10	BSF-100A-DD25
		125	29,500	71,000	11	BSF-125A-DD25
		160	57,000	136,000	13	BSF-160A-DD25
		200	120,000	285,000	14	BSF-200A-DD25
		250	200,000	475,000	18	BSF-250A-DD25
		315	265,000	630,000	25	BSF-315A-DD25

### Dimensions (mm)

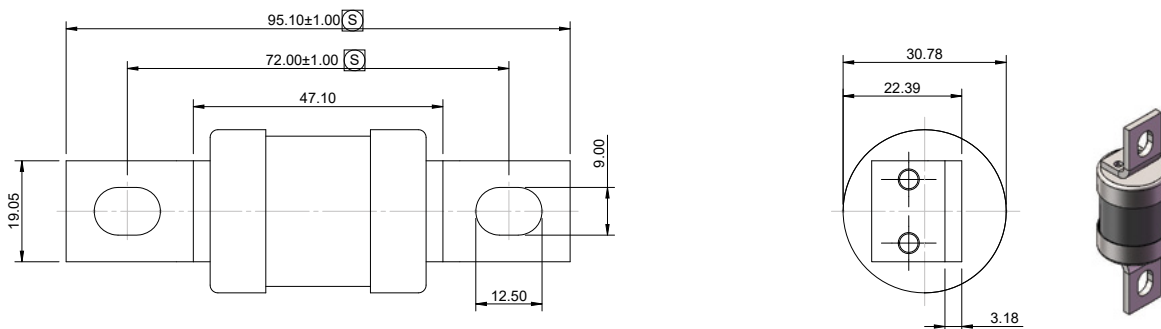

# British standard BS88 fuse links

## 250 V d.c. (IEC/UL) - 80 A to 315 A - BSF-DD25

### Time-current curve

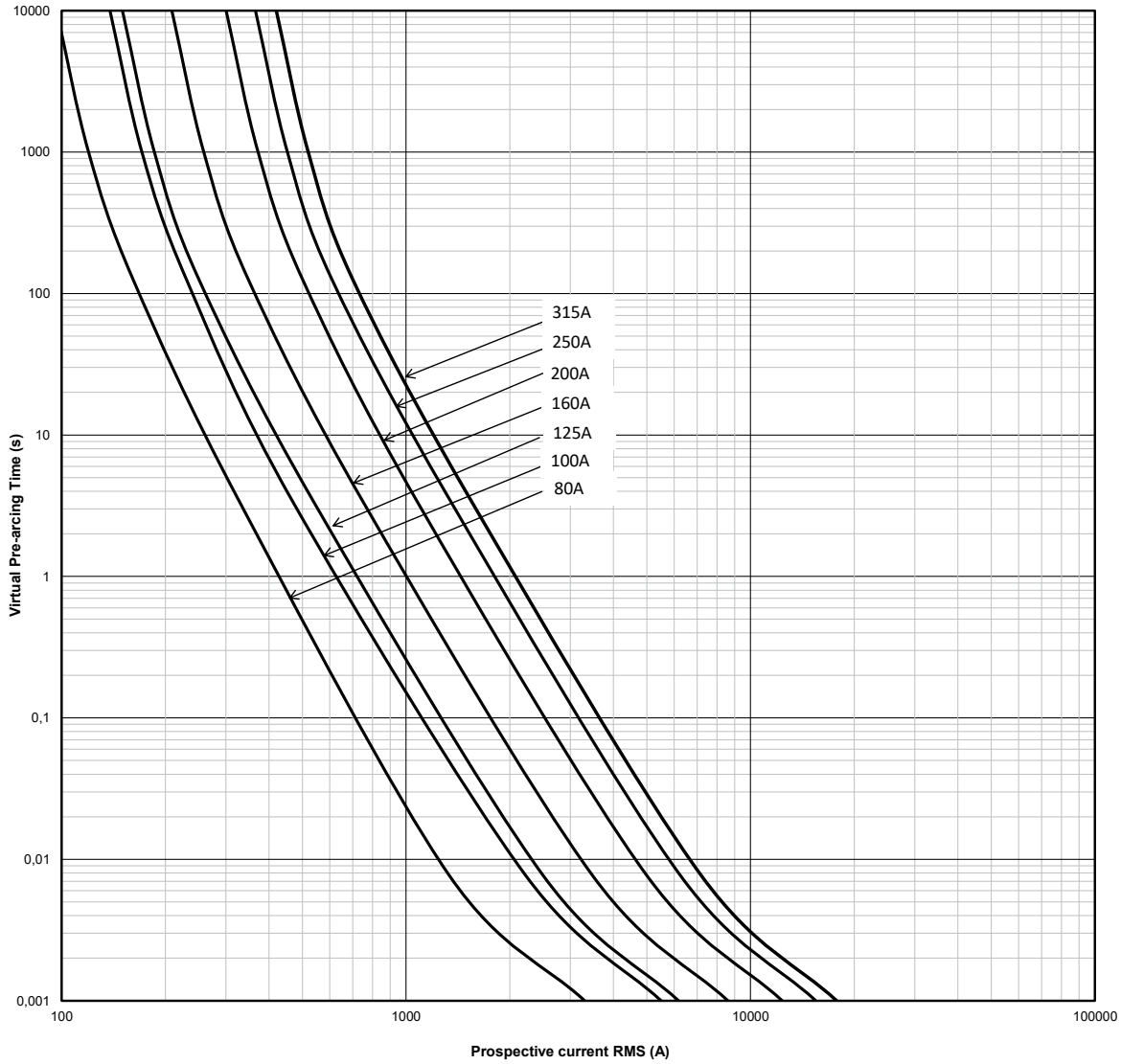

### Watts losses

Watts loss at rated current is given in the electrical characteristics. The curve allows the calculation of the watts losses at load currents lower than the rated current. The correction factor,  $K_p$ , is given as a function of the RMS load current,  $I_b$ , in percent of the rated current.

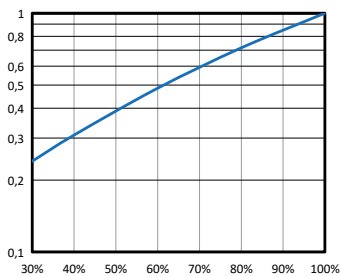

# Ferrule fuse links

## 600 V d.c. (UL) - 5 A to 63 A - FWP - 14 x 51 mm

### Specifications

#### Description

Ferrule style high speed fuse links for the protection of DC common bus, DC drives, power converters/rectifiers and reduced rated voltage starters. Available with or without striker.

#### Technical data

- Rated voltage:
  - Without striker: 700 V d.c. (UL)
  - With striker: 600 V d.c. (UL)
- Rated current:
  - Without striker: 5 A to 63 A
  - With striker: 10 A to 50 A
- Breaking capacity:
  - 50 kA at 700 V d.c. (5 A to 50 A non striker version)
  - 50 kA at 600 V d.c. for striker version
- Operating class: aR

#### Compatible modular fuse holder

- CH14

#### Standards / Agency information

CE, UL recognised & CSA component acceptance for versions without striker only, CCC certified 5 A to 50 A



### Catalog numbers

Fuse link type	Fuse link size	Rated voltage	Rated current (Amps)	Breaking capacity (kA)	I <sup>2</sup> t (A <sup>2</sup> Sec)		Watts loss (W)	Catalog numbers
					Pre-arcing			
Without striker	14 x 51 mm ( $\frac{9}{16}$ " x 2")	700 V d.c. (UL)	5	50	2		1.5	FWP-5A14F
			6	50	2		1.5	FWP-6A14F
			10	50	4		4	FWP-10A14F
			15	50	10		5.5	FWP-15A14F
			20	50	26		6.5	FWP-20A14F
			25	50	49		7	FWP-25A14F
			30	50	58		9	FWP-30A14F
			32	50	68		8	FWP-32A14F
			40	50	84		8	FWP-40A14F
			50	50	200		9	FWP-50A14F
With striker	14 x 51 mm ( $\frac{9}{16}$ " x 2")	600 V d.c. (UL)	10	50	4		2	FWP-10A14FI
			15	50	7		4	FWP-15A14FI
			20	50	26		4	FWP-20A14FI
			25	50	42		4	FWP-25A14FI
			30	50	52		6	FWP-30A14FI
			32	50	68		8	FWP-32A14FI
			40	50	84		8	FWP-40A14FI
			50	50	200		9	FWP-50A14FI

Data sheets: [Z20025](#), 5781724 fuses without striker; 5785566 fuses with striker, 5785626 (63 A)

# Ferrule fuse links

## 600 V d.c. (UL) - 5 A to 63 A - FWP - 14 x 51 mm

### Dimensions - mm (in)

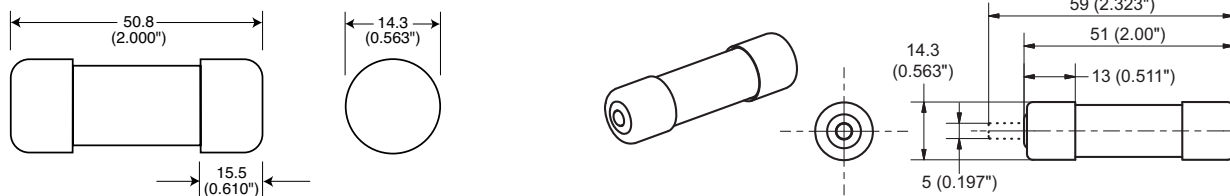

Without striker

With striker

### Time-current curve - 5 A to 50 A

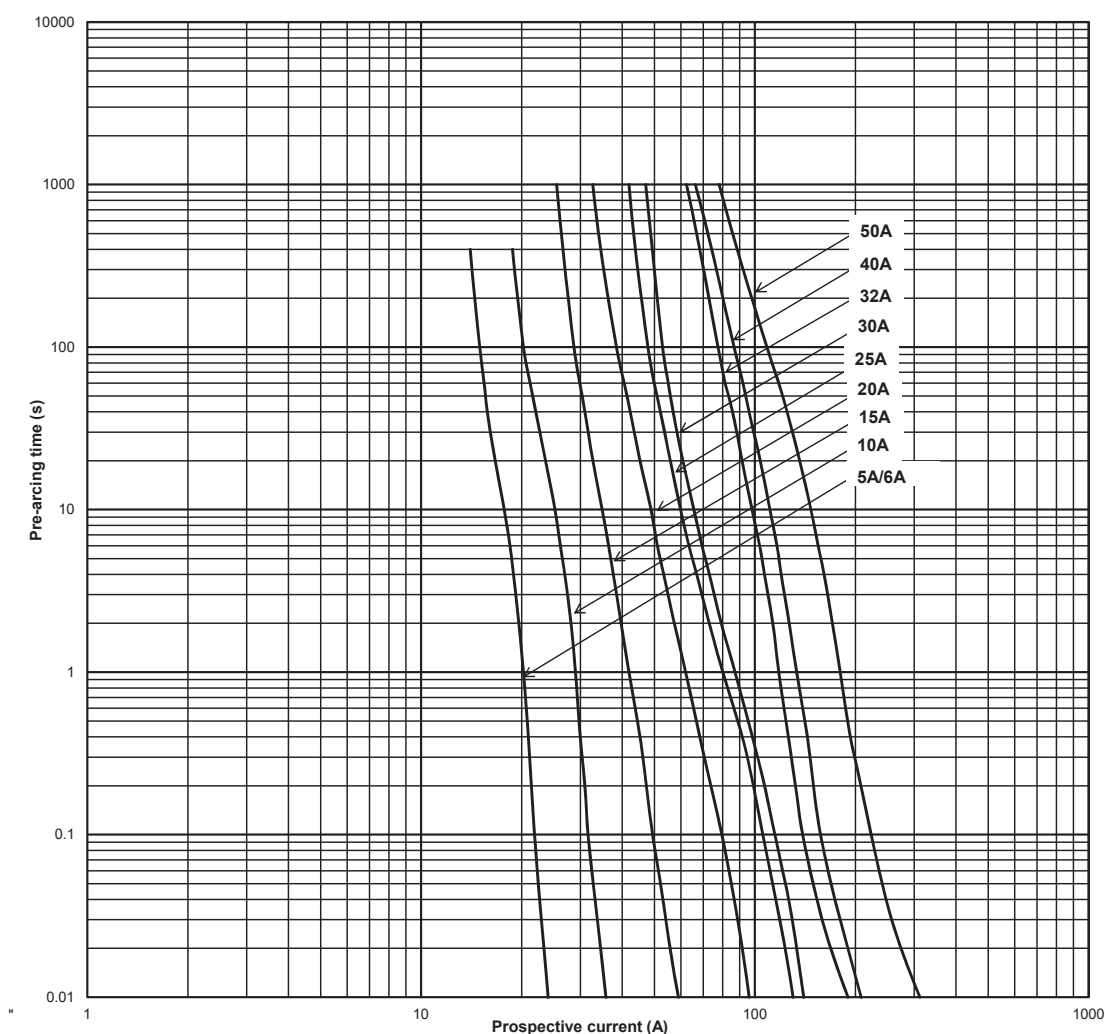

Data sheets: [Z20025](#), 5781724 fuses without striker; 5785566 fuses with striker, 5785626 (63 A)

600 V d.c. (UL) - 5 A to 63 A - FWP - 14 x 51 mm

Time-current curve - 63 A

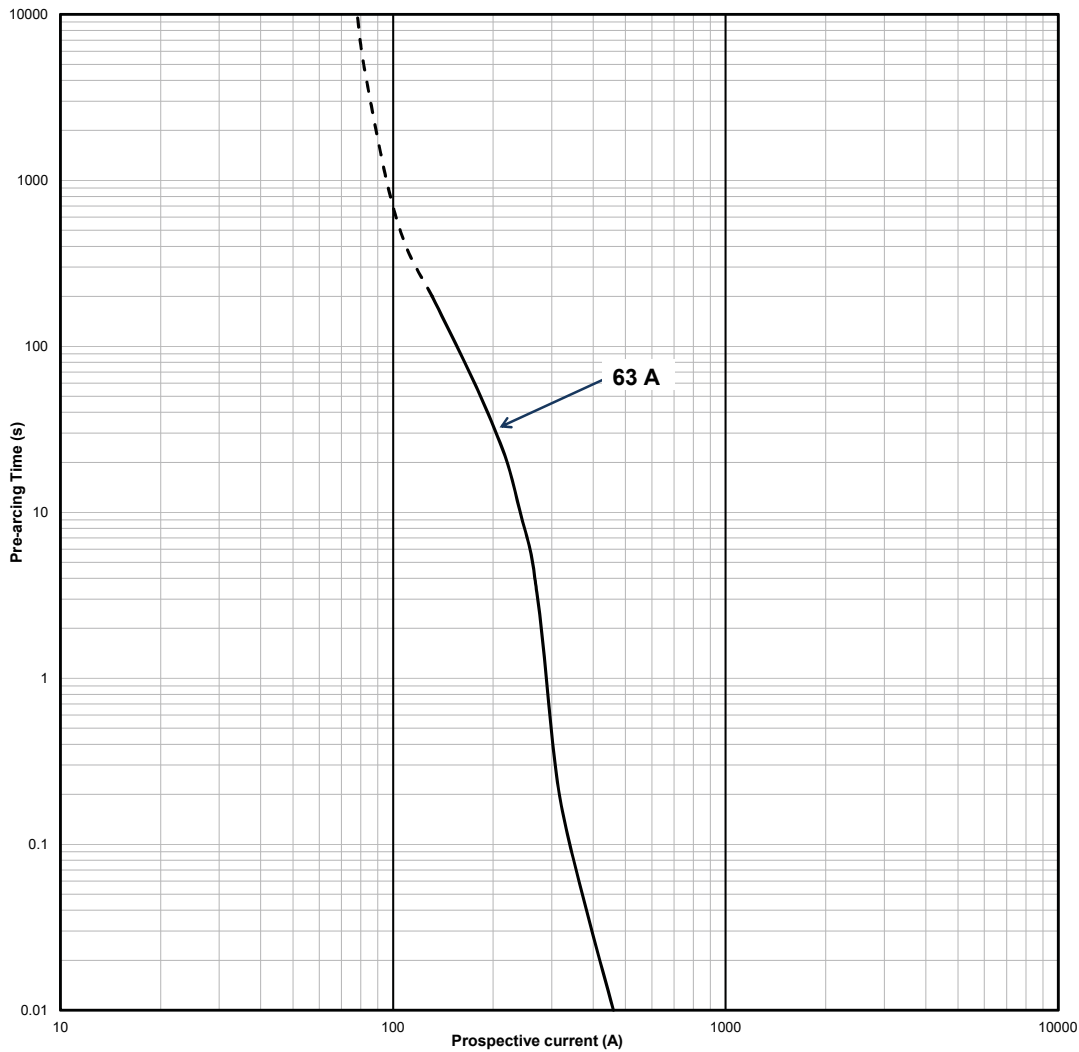

**Watts losses**

Watts loss at rated current is given in the electrical characteristics. The curve allows the calculation of the watts losses at load currents lower than the rated current. The correction factor,  $K_p$ , is given as a function of the RMS load current,  $I_b$ , in percent of the rated current.

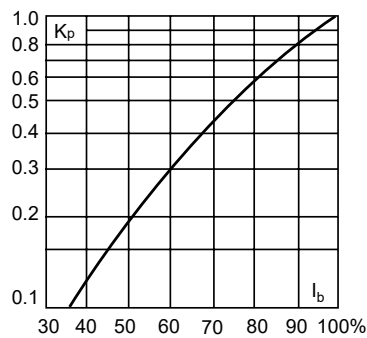

Data sheets: [Z20025](#), 5781724 fuses without striker; 5785566 fuses with striker, 5785626 (63 A)

# Ferrule fuse links

## 1000 V d.c. (IEC), 1125 V d.c. (UL) - 12 A to 30 A - 180D - 10 x 85 mm

### Specifications

#### Description

Eaton's Bussmann series 180D gR DC fuse links size 10 x 85 mm are specifically designed for the protection of DC auxiliary circuits, offering reliable cable protection.

#### Technical data

- Rated voltage: 1000 V d.c. (IEC) 1125 V d.c. (UL)
- Rated current: 12 A to 30 A
- Breaking capacity: 100 kA
- Operating class: gR

#### Standards / Agency information

Designed and tested to IEC 60269 part 4, UL 248-13 Recognised, RoHS compliant

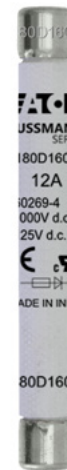

#### Catalog numbers

Fuse body size	Rated voltage	Rated current (Amps)	Breaking capacity (kA at 10ms)	Pre-arcing I <sup>2</sup> t (A <sup>2</sup> Sec)	Power loss at I <sub>n</sub> (W)	Catalog number
10 x 85 mm	1000 V d.c. (IEC)	12	100	19	3.5	180D1602
	1125 V d.c. (UL)	15	100	42	3.6	180D1603
		20	100	108	4.5	180D1604
		25	100	190	5.6	180D1605
		30	100	485	6.6	180D1606

#### Dimensions (mm)

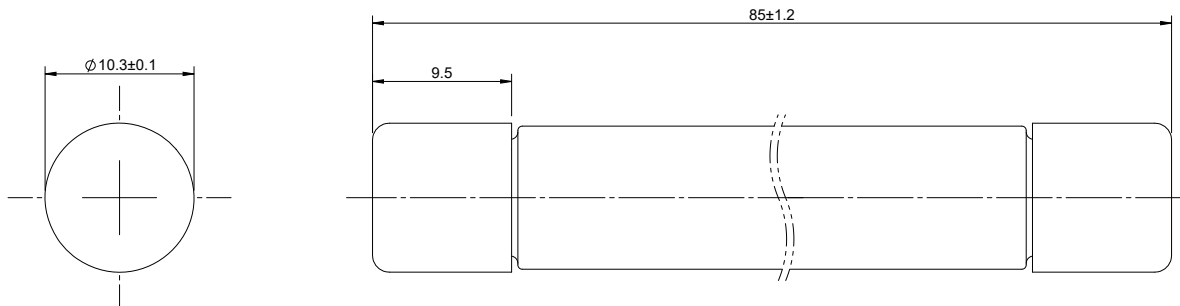

1000 V d.c. (IEC), 1125 V d.c. (UL) - 12 A to 30 A - 180D - 10 x 85 mm

Time-current curve

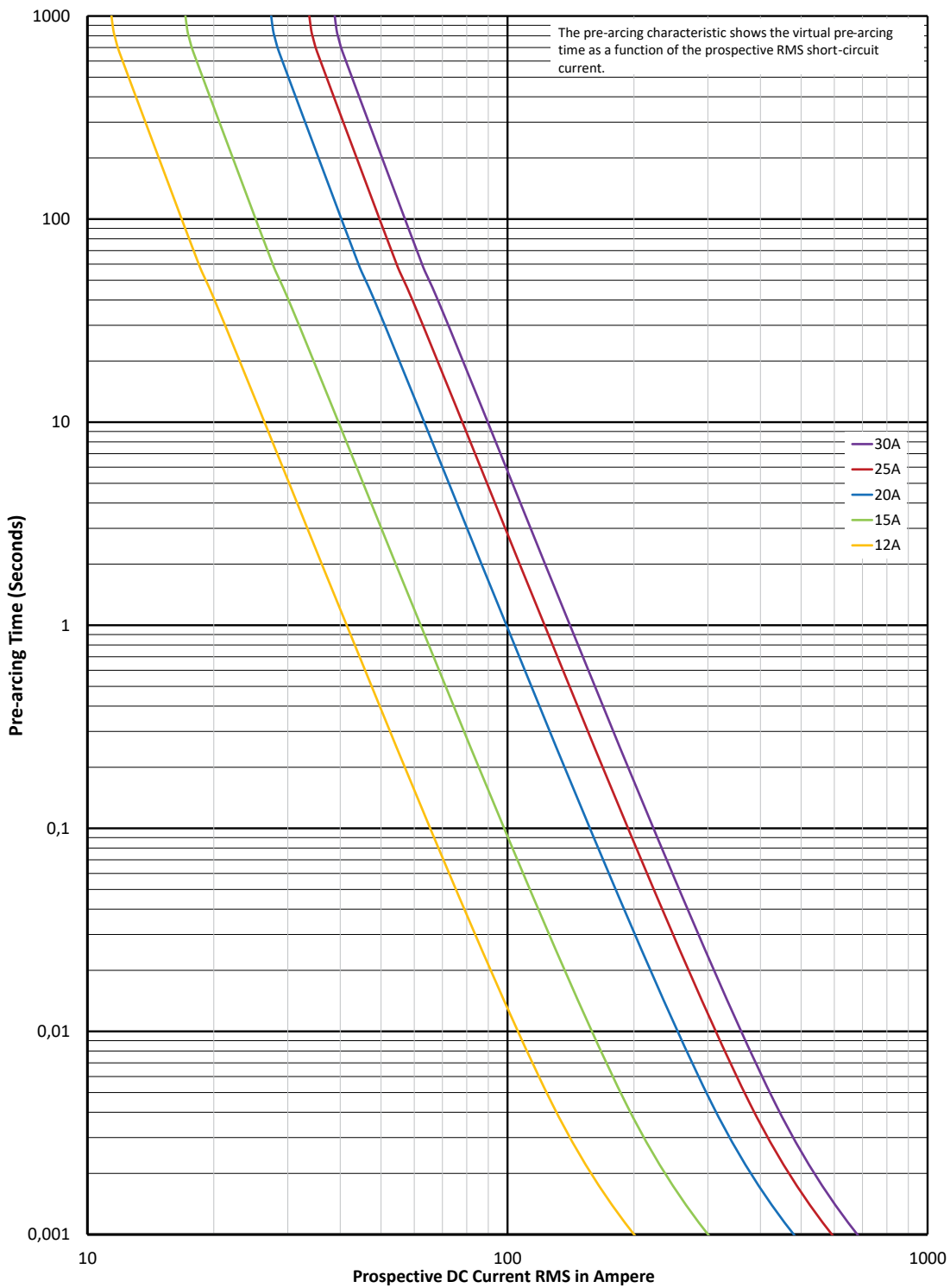

$K_b = 1$   $N = 1,6$

# Ferrule fuse links

1000 V d.c. (IEC), 1125 V d.c. (UL) - 12 A to 30 A - 180D - 10 x 85 mm

## Peak let-through curve

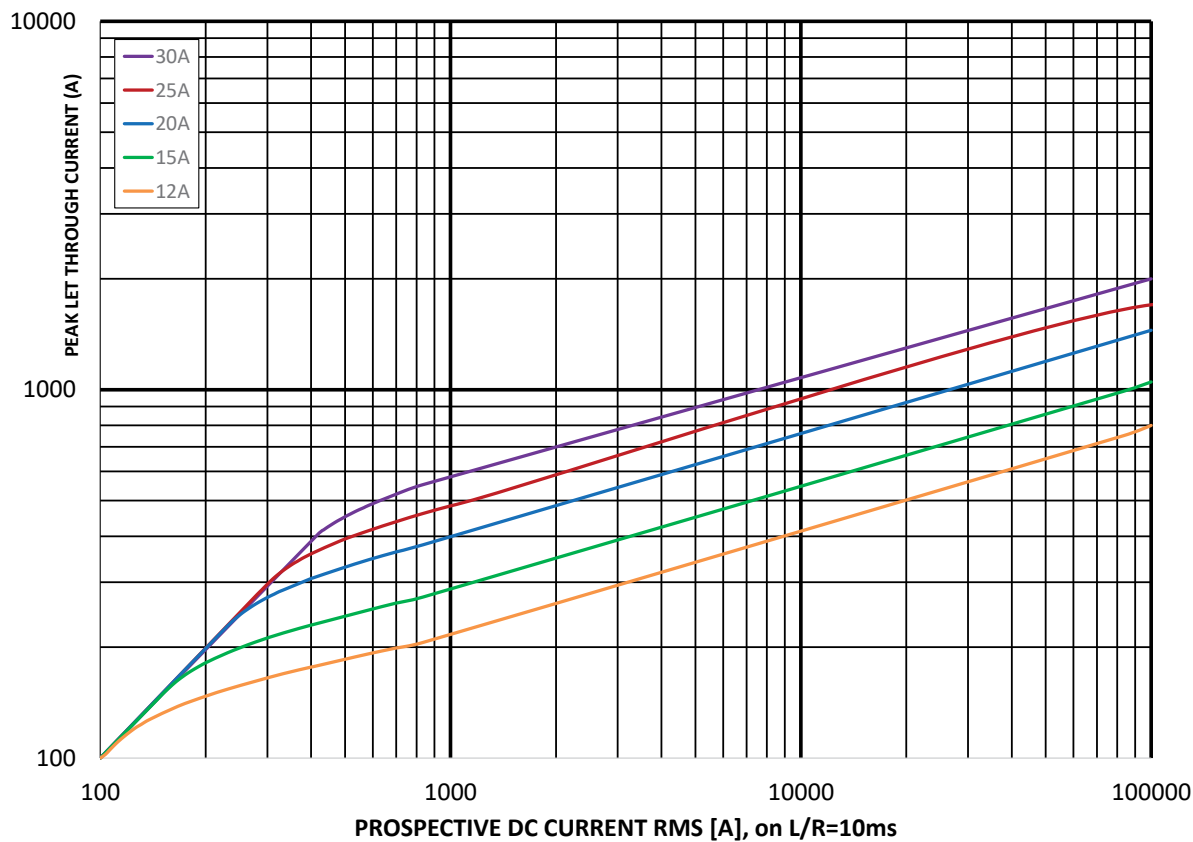

## Watts losses

Watts loss at rated current is given in the electrical characteristics. The curve allows the calculation of the watts losses at load currents lower than the rated current. The correction factor,  $K_p$ , is given as a function of the RMS load current,  $I_b$ , in percent of the rated current.

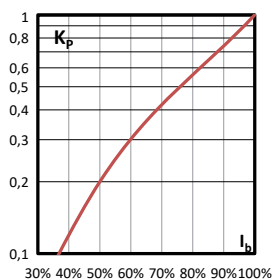

# Square body fuse links

## 500 V d.c. (IEC/UL) - 50 A to 500 A - 180D - Flush end contact fuse body size 1\*

### Specifications

#### Description

Eaton's Bussmann™ series 500 V d.c. aR square body fuse links deliver fast, dependable protection for advanced DC systems, including DC common bus, EV charging infrastructure, DC drives, and power conversion applications.

#### Technical data

- Rated voltage: 500 V d.c. (IEC/UL)
- Rated current: 50 A to 500 A
- Breaking capacity: 100 kA
- Operating class: aR



#### Standards / Agency information

Designed and tested to IEC 60269 part 4, UL 248-13 Recognised, RoHS compliant

#### Catalog numbers - BN/50 and BKN/50

Fuse body size	Rated voltage	Rated current (Amps)	Breaking capacity (kA)	Minimum pre-arcing I <sup>2</sup> t (A <sup>2</sup> Sec)	Max clearing integral A2s at 500 VDC 10 ms L/R	Minimum breaking current (A) @ 500VDC	Power loss in (W)	Catalog number	
								Fuse type: BN/50	Fuse type: BKN/50*
1*	500 V d.c. (IEC/UL)	50	100	77	308	125	13	180D0009	180D3459*
		63	100	115	460	150	17	180D0010	180D3460*
		80	100	185	740	200	21	180D0011	180D3461*
		100	100	360	1440	250	24	180D0012	180D3462*
		125	100	550	2200	350	30	180D0013	180D3463*
		160	100	1100	4400	450	34	180D0014	180D3464*
		200	100	2200	8800	650	41	180D0015	180D3465*
		215	100	4200	16,800	850	47	180D0016	180D3466*
		315	100	7000	28,000	1100	61	180D0017	180D3467*
		350	100	10,000	40,000	1300	64	180D0018	180D3468*
		400	100	15,000	60,000	1600	69	180D0019	180D3469*
		450	100	21,000	84,000	1800	75	180D0020	180D3470*
		500	100	27,000	108,000	2000	83	180D0021	180D3471*

\* Available on request, please contact [bulehighspeedtechnical@eaton.com](mailto:bulehighspeedtechnical@eaton.com)

# Square body fuse links

## 500 V d.c. (IEC/UL) - 50 A to 500 A - 180D - Flush end contact fuse body size 1\*

Catalog numbers - GN/50 and GKN/50

Fuse body size	Rated voltage	Rated current (Amps)	Breaking capacity (kA)	Minimum pre-arcing $I^2t$ (A <sup>2</sup> Sec)	Max clearing integral A2s at 500 VDC 10 ms L/R	Minimum breaking current (A) @ 500VDC	Power loss at $I_n$ (W)	Catalog number	
								Fuse type: GN/50	Fuse type: GKN/50
1*	500 V d.c. (IEC/UL)	50	100	77	308	125	13	180D3509	180D3559
		63	100	115	460	150	17	180D3510	180D3560
		80	100	185	740	200	21	180D3511	180D3561
		100	100	360	1440	250	24	180D3512	180D3562
		125	100	550	2200	350	30	180D3513	180D3563
		160	100	1100	4400	450	34	180D3514	180D3564
		200	100	2200	8800	650	41	180D3515	180D3565
		215	100	4200	16,800	850	47	180D3516	180D3566
		315	100	7000	28,000	1100	61	180D3517	180D3567
		350	100	10,000	40,000	1300	64	180D3518	180D3568
		400	100	15,000	60,000	1600	69	180D3519	180D3569
		450	100	21,000	84,000	1800	75	180D3520	180D3570
		500	100	27,000	108,000	2000	83	180D3521	180D3571

### Dimensions (mm) - BN/50

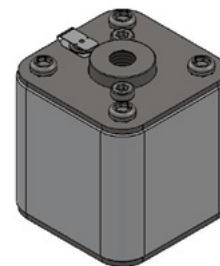
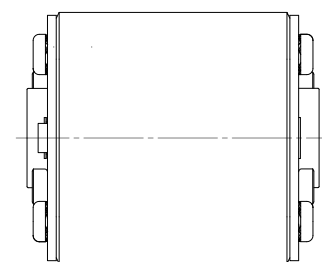
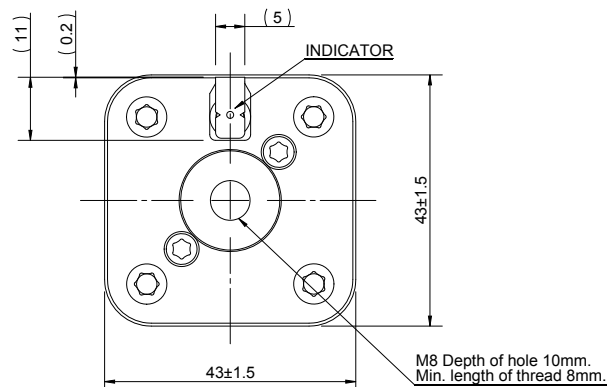
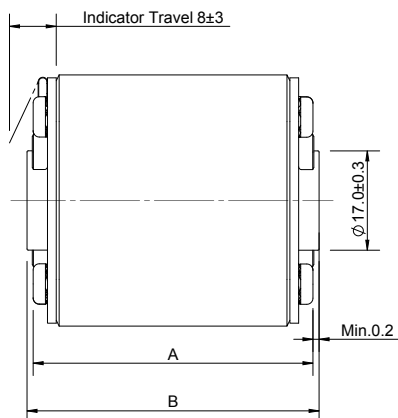

A	B
48.5 ± 1.5	50 ± 1.2

Data sheets 180K0032 BN/50, 180K0032 BKN/50, 180K0032 GN/50 and GKN/50

500 V d.c. (IEC/UL) - 50 A to 500 A - 180D - Flush end contact fuse body size 1\*

Dimensions (mm) - BKN/50

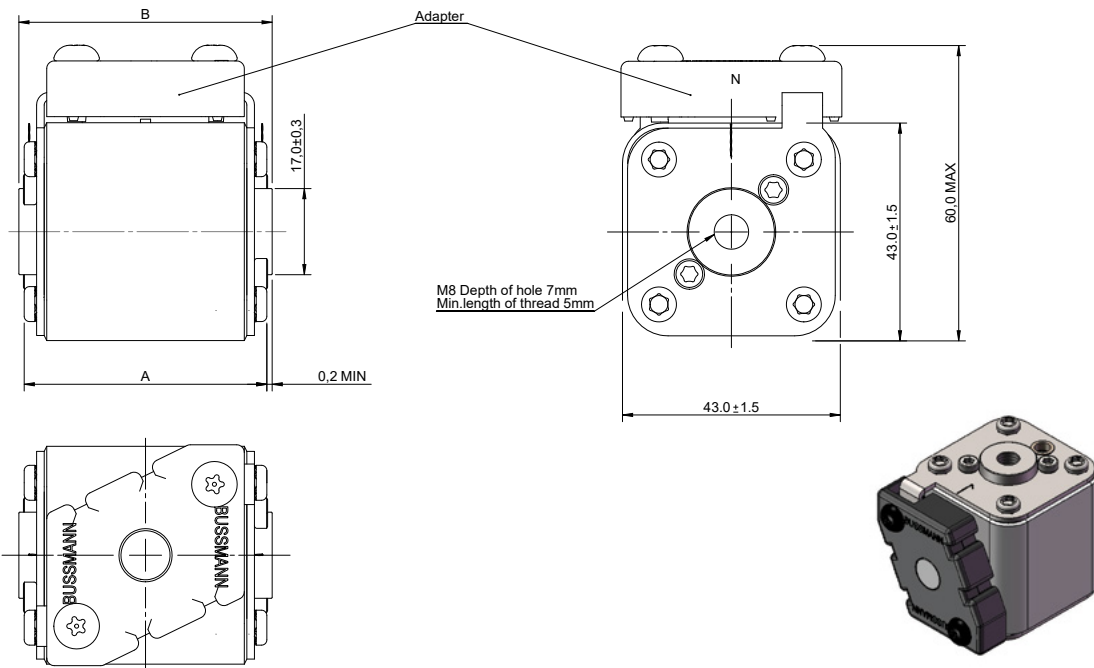

A	B
48.5 ± 1.5	50 ± 1.2

Dimensions (mm) - GN/50

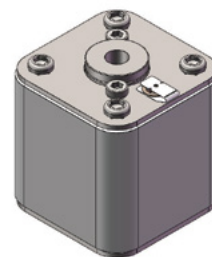
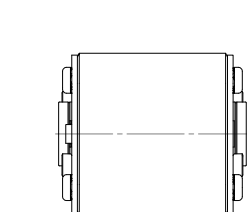
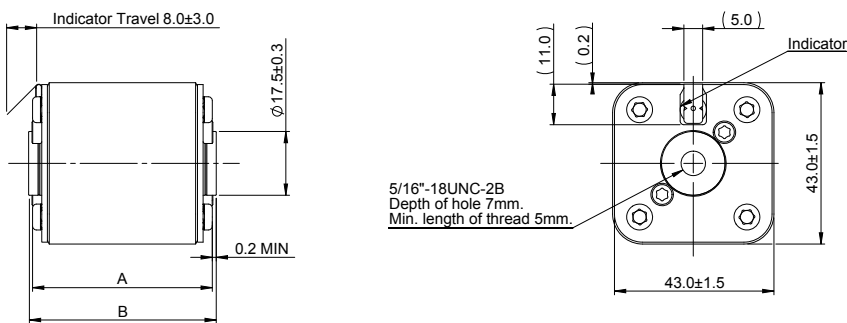

A	B
48.5 ± 1.5	50 ± 1.2

Data sheets 180K0032 BN/50, 180K0032 BKN/50, 180K0032 GN/50 and GKN/50

# Square body fuse links

500 V d.c. (IEC/UL) - 50 A to 500 A - 180D - Flush end contact fuse body size 1\*

Dimensions (mm) - GKN/50

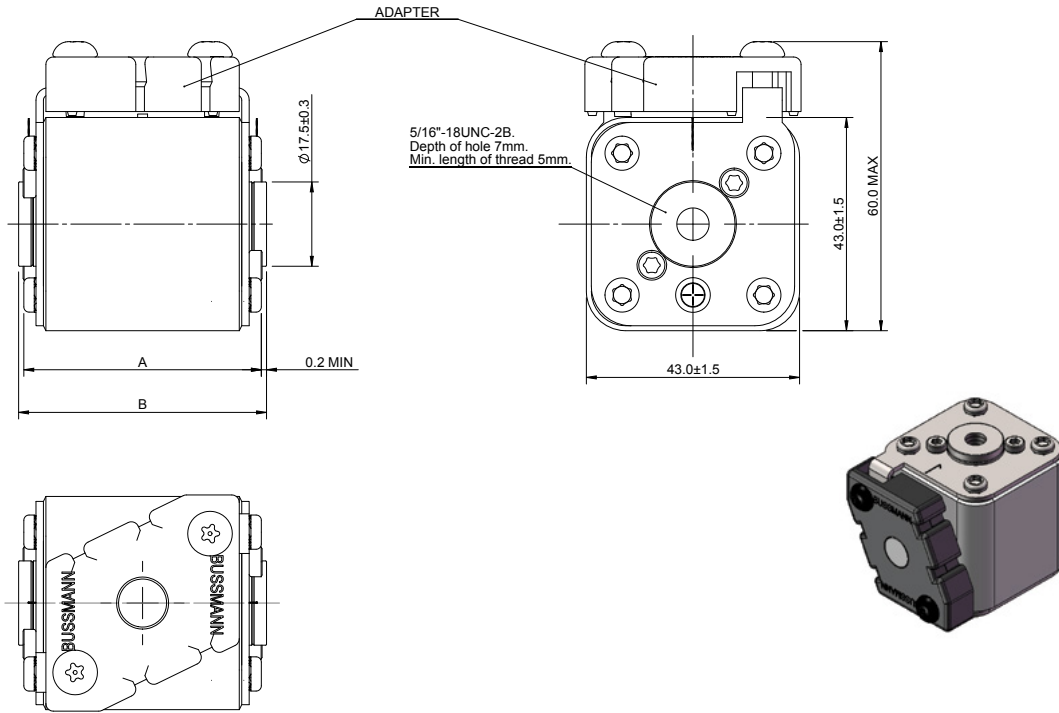

A	B
48.5 $\pm$ 1.5	50 $\pm$ 1.2

500 V d.c. (IEC/UL) - 50 A to 500 A - 180D - Flush end contact fuse body size 1\*

Time-current curve

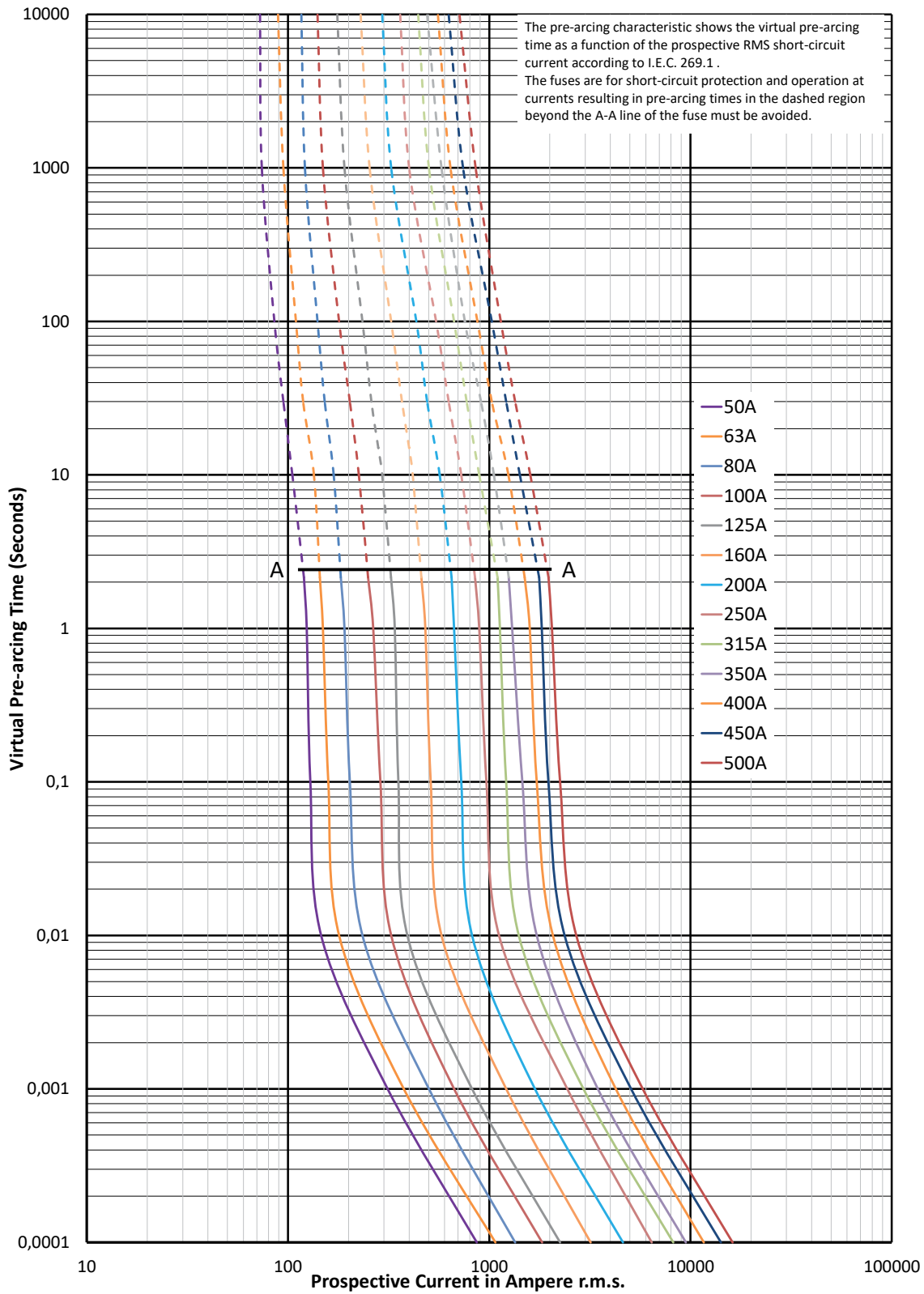

$K_b = 1$

# Square body fuse links

## 500 V d.c. (IEC/UL) - 50 A to 500 A - 180D - Flush end contact fuse body size 1\*

### Peak let-through curve

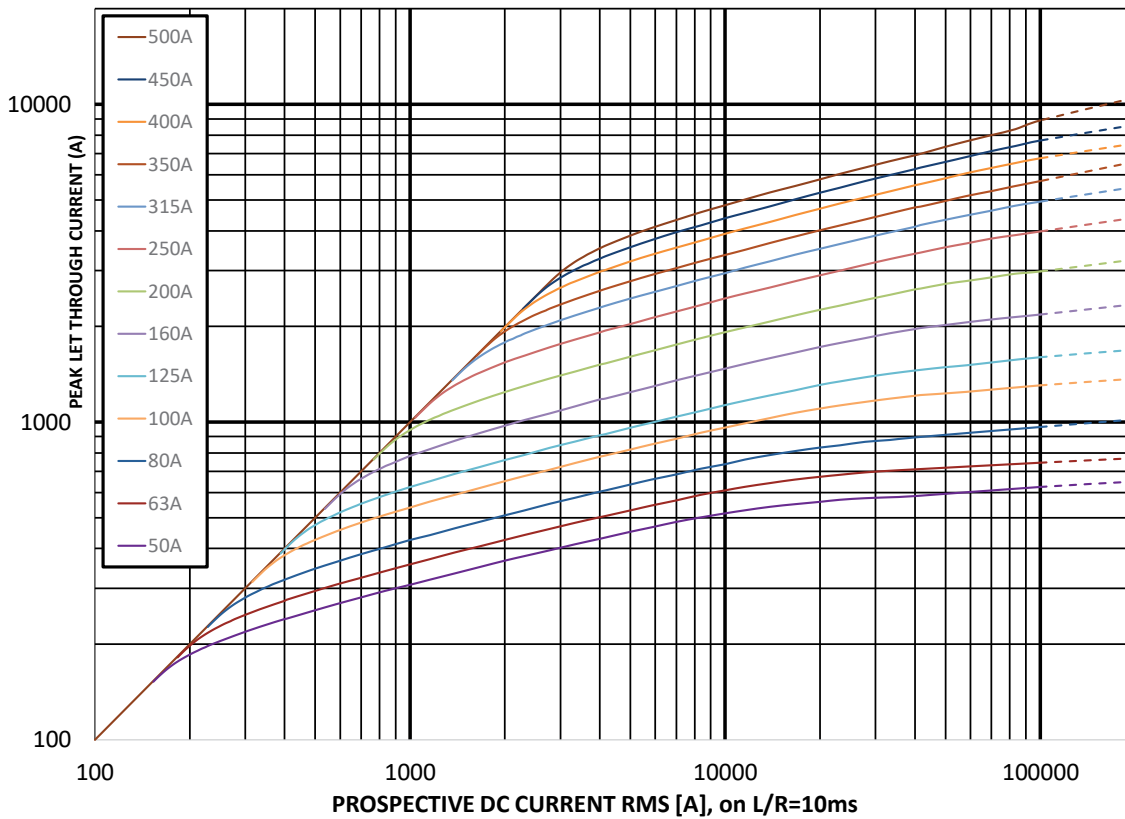

### Watts losses

Watts loss at rated current is given in the electrical characteristics. The curve allows the calculation of the watts losses at load currents lower than the rated current. The correction factor,  $K_p$ , is given as a function of the RMS load current,  $I_b$ , in percent of the rated current.

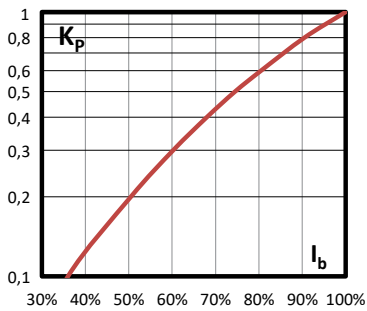

## 800 V d.c. (IEC/UL) - 32 A to 50 A - 180D - DIN1HT Fuse body size 1

### Specifications

#### Description

Eaton's Bussmann™ series 800 V d.c. gR square body fuse links deliver fast, dependable protection for advanced DC systems, including DC common bus, EV charging infrastructure, DC drives, and power conversion applications.

#### Technical data

- Rated voltage: 800 V d.c. (IEC and UL)
- Rated current: 32 A to 50 A
- Breaking capacity: 100 kA
- Operating class: gR

#### Compatible fuse base

SD1-D-PV

#### Standards / Agency information

Designed and tested to IEC 60269 part 4, UL 248-13 Recognised, RoHS compliant

#### Catalog numbers

Fuse body size	Rated voltage	Rated current (Amps)	Breaking capacity (kA at 10ms)	Minimum pre-arcing integral (from cold) A²S	Maximum clearing integral A2S @ 800 V d.c. 10 ms L/R	Minimum breaking current (A) @ 800 V d.c.	Power loss at I <sub>n</sub> (W)	Catalog number
DIN1HT	800 V d.c. (IEC/UL)	32	100	80	690	64	8.5	180D1506
		40	100	185	1600	80	9	180D1507
		50	100	400	3450	100	11	180D1508



#### Dimensions (mm)

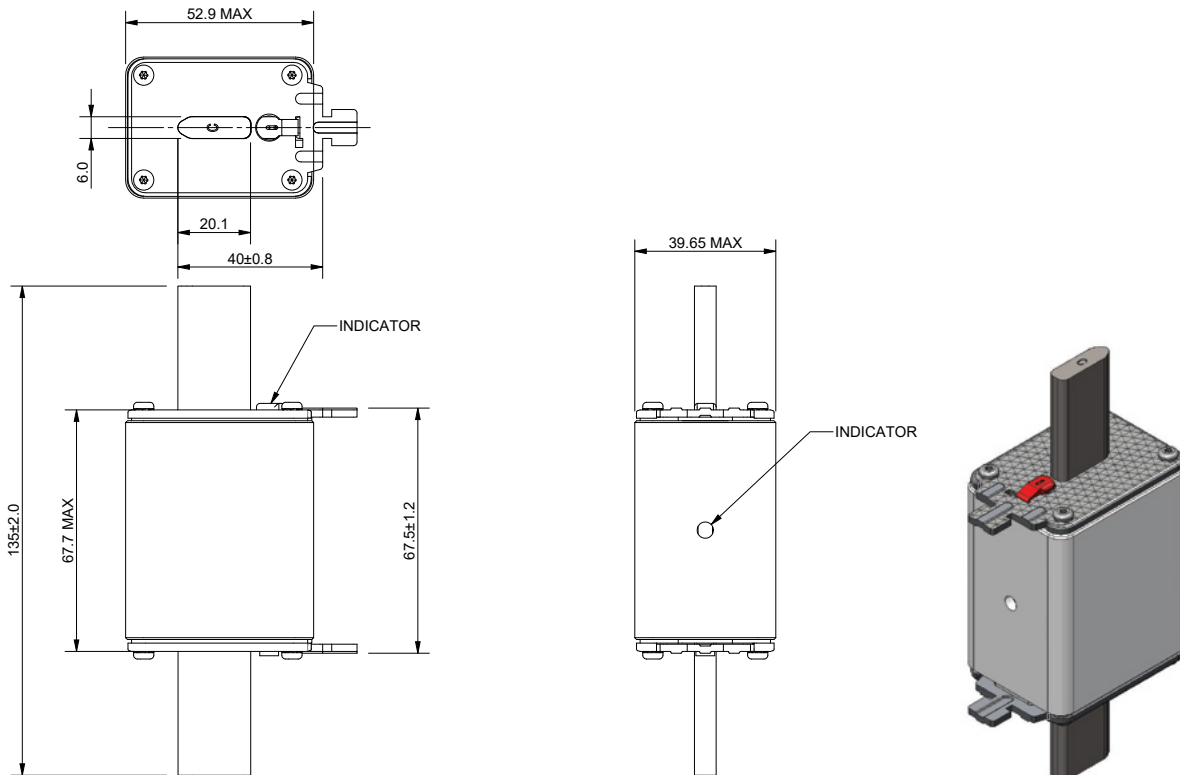

Data sheet: [TD135014EN](#)

# Square body fuse links

## 800 V d.c. (IEC/UL) - 32 A to 50 A - 180D - DIN1HT Fuse body size 1

### Time-current curve

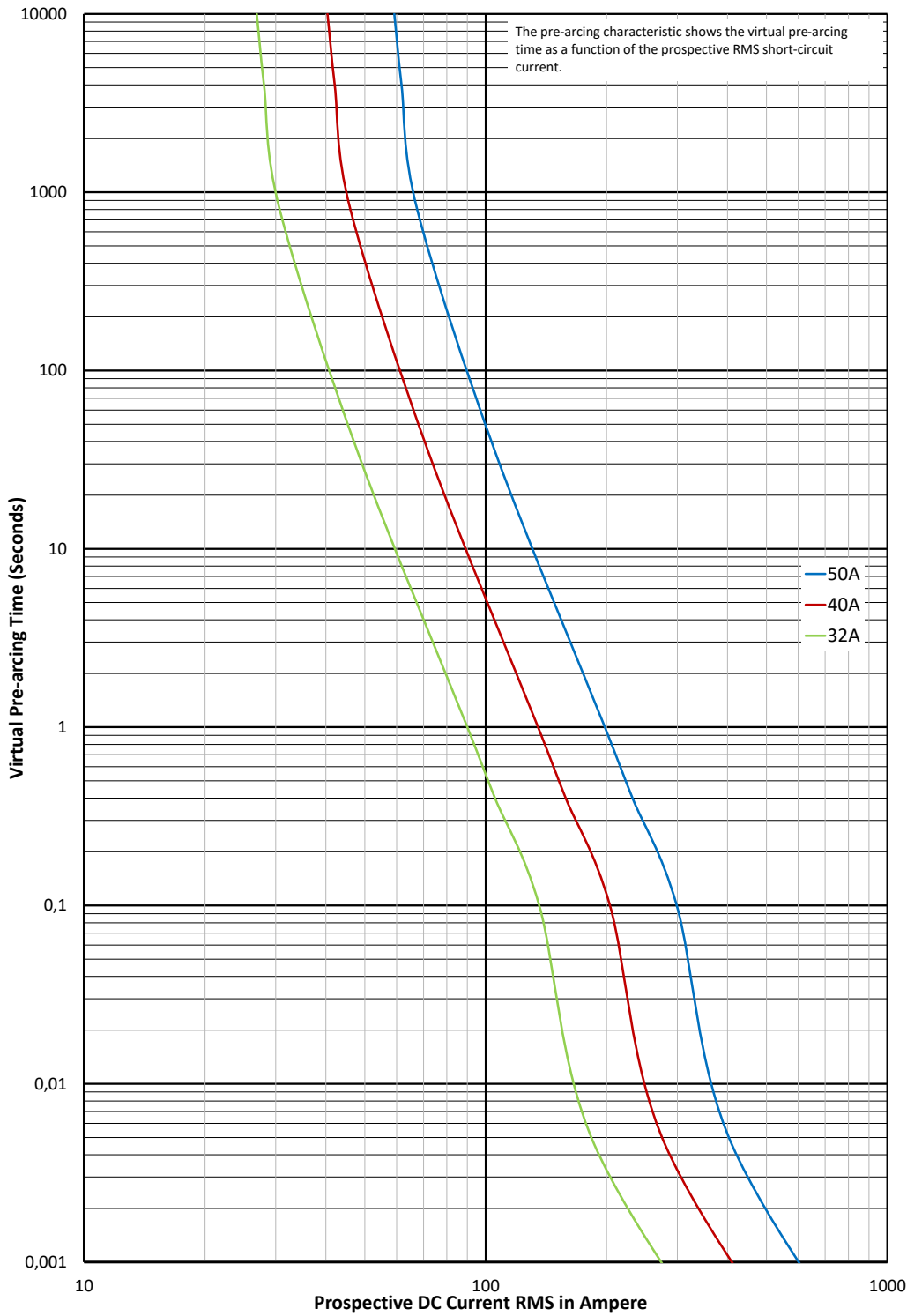

$K_b = 1$   $N = 1,6$

800 V d.c. (IEC/UL) - 32 A to 50 A - 180D - DIN1HT Fuse body size 1

Peak let-through curve

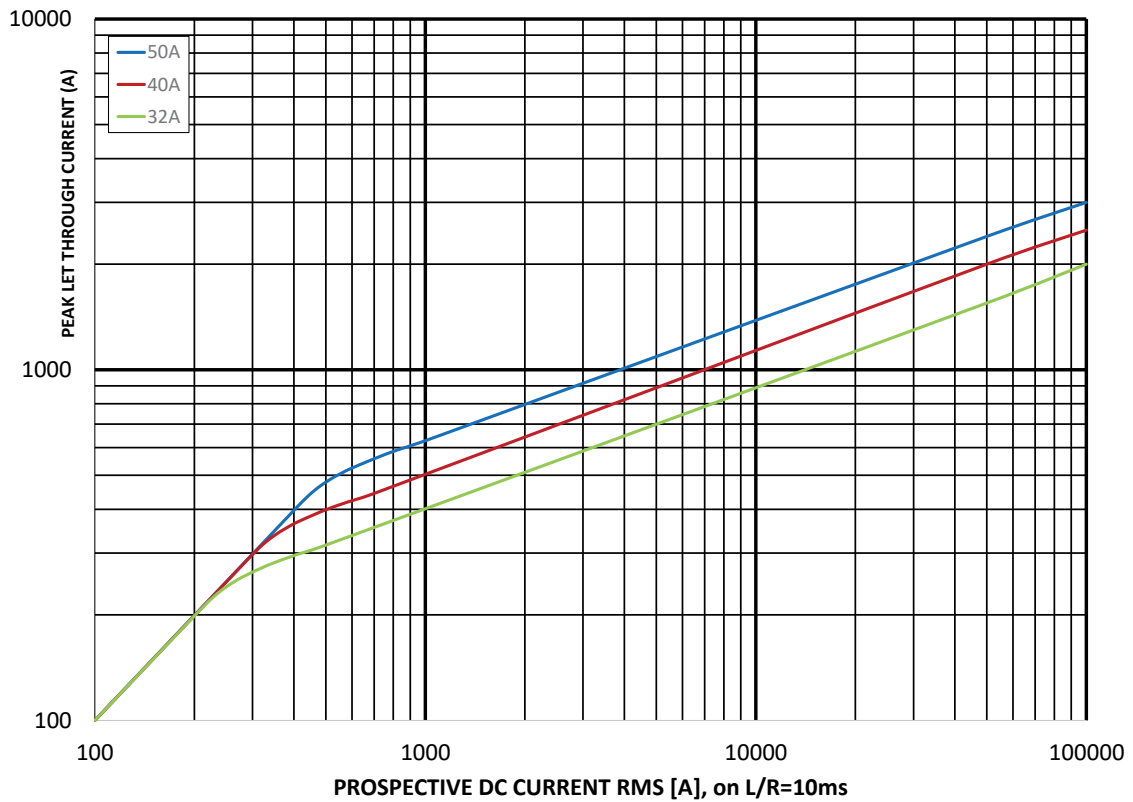

Watts losses

Watts loss at rated current is given in the electrical characteristics. The curve allows the calculation of the watts losses at load currents lower than the rated current. The correction factor,  $K_p$ , is given as a function of the RMS load current,  $I_b$ , in percent of the rated current.

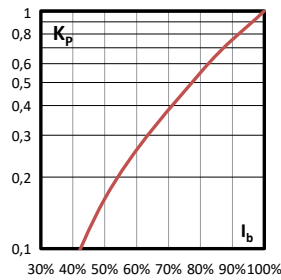

# Square body fuse links

## 800 V d.c. (IEC/UL) - 500 A to 630 A - 180D - Flush end contact and DIN Fuse body size 1

### Specifications

#### Description

Eaton's Bussmann™ series 800 V d.c. aR and aBat square body fuse links deliver fast, dependable protection for advanced DC systems, including DC common bus, EV charging infrastructure, DC drives, and power conversion applications.

#### Technical data

- Rated voltage: 800 V d.c. (IEC and UL)
- Rated current: 500 A to 630 A
- Breaking capacity: 100 kA
- Operating class: aR and aBat

#### Standards / Agency information

Designed and tested to IEC 60269 part 4 and 7, UL 248-13  
Recognised, RoHS compliant

#### Catalog numbers



#### Catalog number

Fuse body size	Rated voltage	Rated current (Amps)	Breaking capacity (kA at 10ms)	Pre-arcing I <sup>2</sup> t (A <sup>2</sup> Sec)	Power loss at In (W)	Fuse type: BKN/75	Fuse type: GKN/75
1	800 V d.c. (IEC/UL)	500	100	69,500	91	180D4395	180D4495
		550	100	95,000	100	180D4396	180D4496
		630	100	130,000	119	180D4397	N/A
		630	100	130,000	119	180D4497	N/A

#### Dimensions (mm) - 1BKN/75

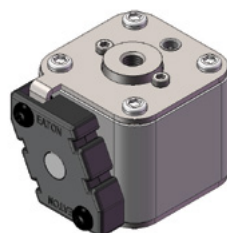
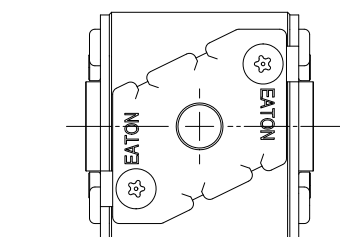
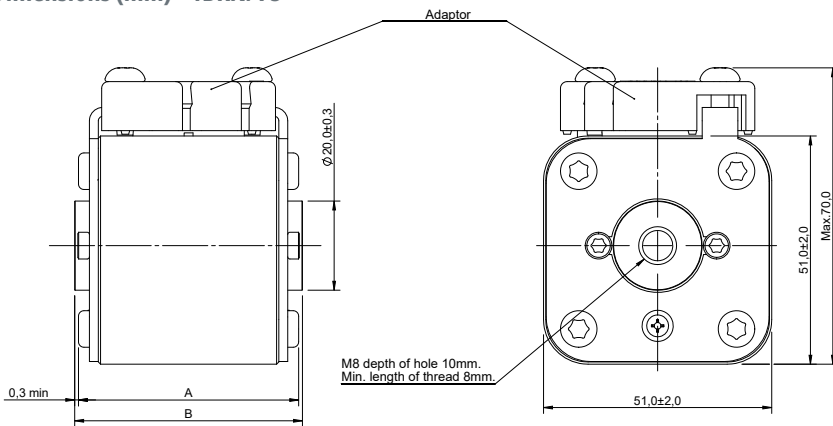

A	B
72.9 ± 1.6	74.6 ± 1.3

800 V d.c. (IEC/UL) - 500 A to 630 A - 180D - Flush end contact and DIN Fuse body size 1

Dimensions (mm) - 1GKN/75

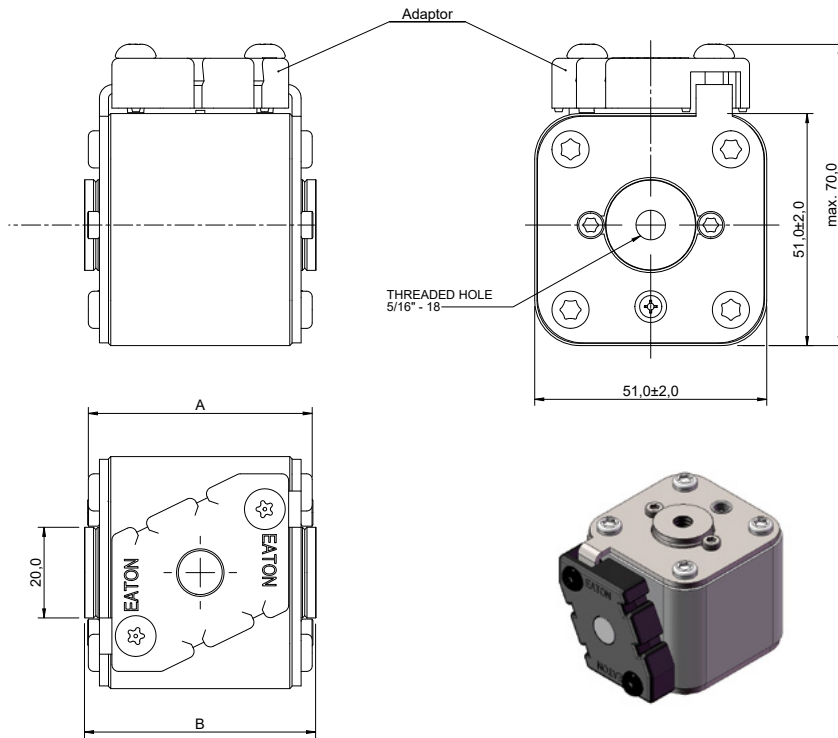

A	B
72.9 ± 1.6	74.6 ± 1.1

# Square body fuse links

## 800 V d.c. (IEC/UL) - 500 A to 630 A - 180D - Flush end contact and DIN Fuse body size 1

Time-current curve

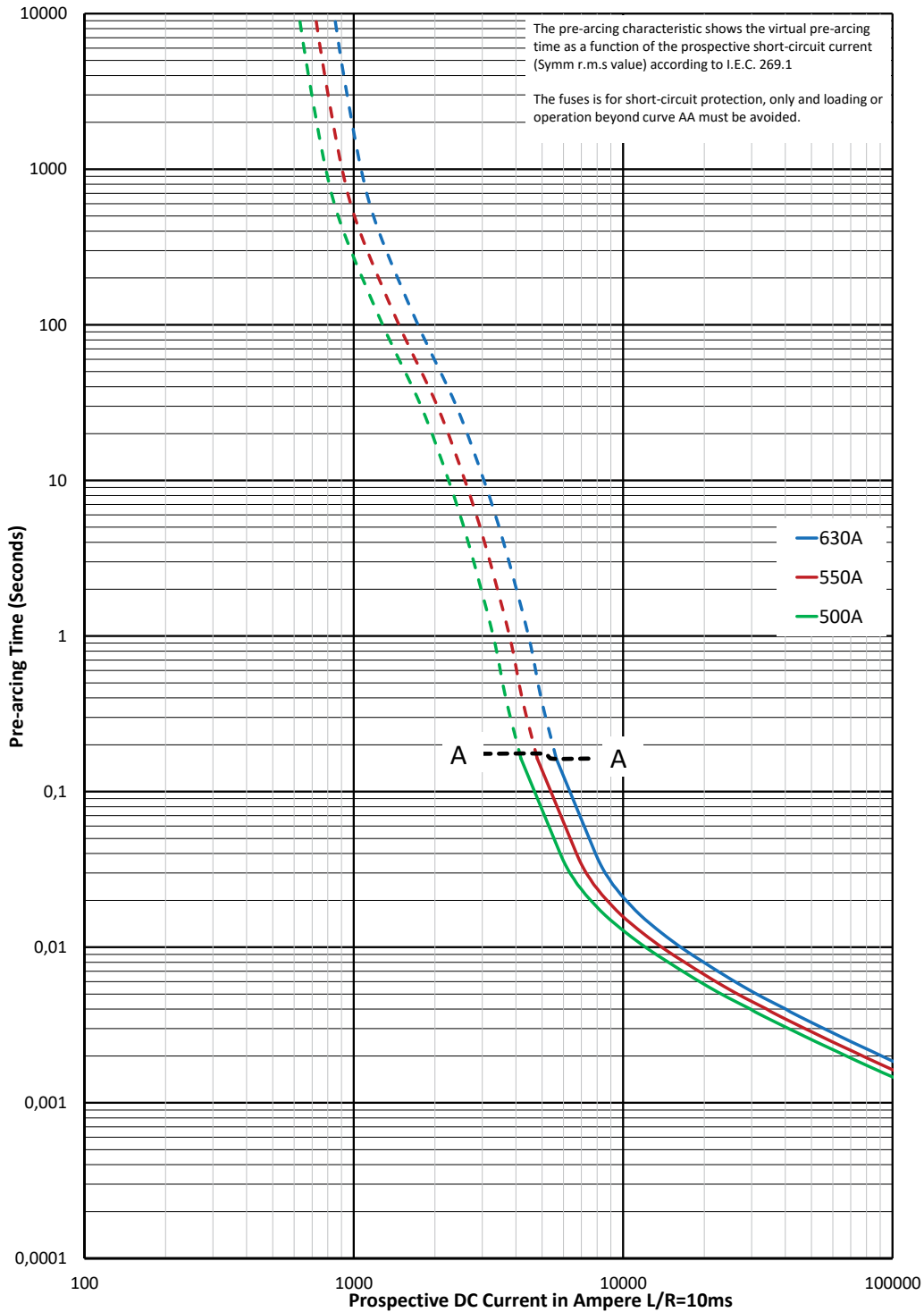

$K_b = 1 \quad N = 1,5$

800 V d.c. (IEC/UL) - 500 A to 630 A - 180D - Flush end contact and DIN Fuse body size 1

Peak let-through curve

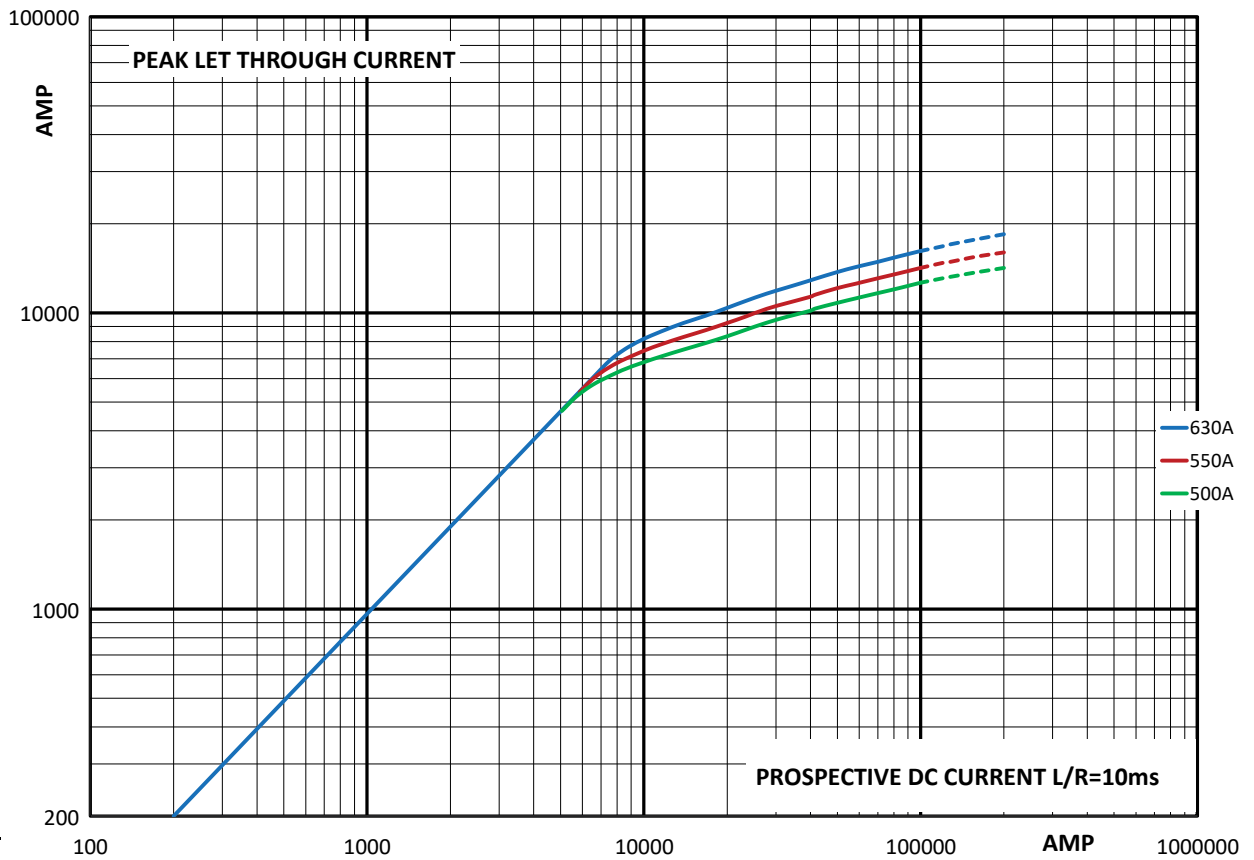

Watts losses

Watts loss at rated current is given in the electrical characteristics. The curve allows the calculation of the watts losses at load currents lower than the rated current. The correction factor,  $K_p$ , is given as a function of the RMS load current,  $I_b$ , in percent of the rated current.

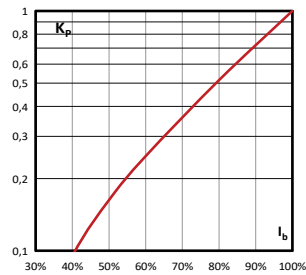

# Square body fuse links

## 800 V d.c. (IEC), 900 V d.c. (UL) - 50 A to 350 A - 180D - Flush end contact fuse body size 1\*

### Specifications

#### Description

Eaton's Bussmann™ series 800 V d.c./900 V d.c. aR square body fuse links deliver fast, dependable protection for advanced DC systems, including DC common bus, EV charging infrastructure, DC drives, and power conversion applications.

#### Technical data

- Rated voltage: 800 V d.c. (IEC), 900 V d.c. (UL)
- Rated current: 50 A to 350 A
- Breaking capacity: 100 kA
- Operating class: aR

#### Standards / Agency information

Designed and tested to IEC 60269 part 4, UL 248-13 Recognised, RoHS compliant



### Catalog numbers

Fuse body size	Rated voltage	Rated current (Amps)	Breaking capacity (kA at 10ms)	Pre-arcing I <sup>2</sup> t (A <sup>2</sup> Sec)	Power loss at In (W)	Catalog number			
						Fuse type: BKN/75	Fuse type: GKN/75	Fuse type: FU/115	Fuse type: FKE/115
1*	800 V d.c. (IEC)	50	100	135	15	180D3388	180D3488	180D3688	180D3738
	900 V d.c. (UL)	63	100	215	20	180D3389	180D3489	180D3689	180D3739
		80	100	420	25	180D3390	180D3490	180D3690	180D3740
		100	100	750	30	180D3391	180D3491	180D3691	180D3741
		125	100	1450	35	180D3392	180D3492	180D3692	180D3742
		160	100	2600	40	180D3393	180D3493	180D3693	180D3743
		200	100	5150	45	180D3394	180D3494	180D3694	180D3744
		250	100	9200	55	180D3395	180D3495	180D3695	180D3745
		315	100	18,500	60	180D3396	180D3496	180D3696	180D3746
		350	100	27,000	65	180D3397	180D3497	180D3697	180D3747

800 V d.c. (IEC), 900 V d.c. (UL) - 50 A to 350 A - 180D - Flush end contact fuse body size 1\*

Dimensions (mm) - BKN/75

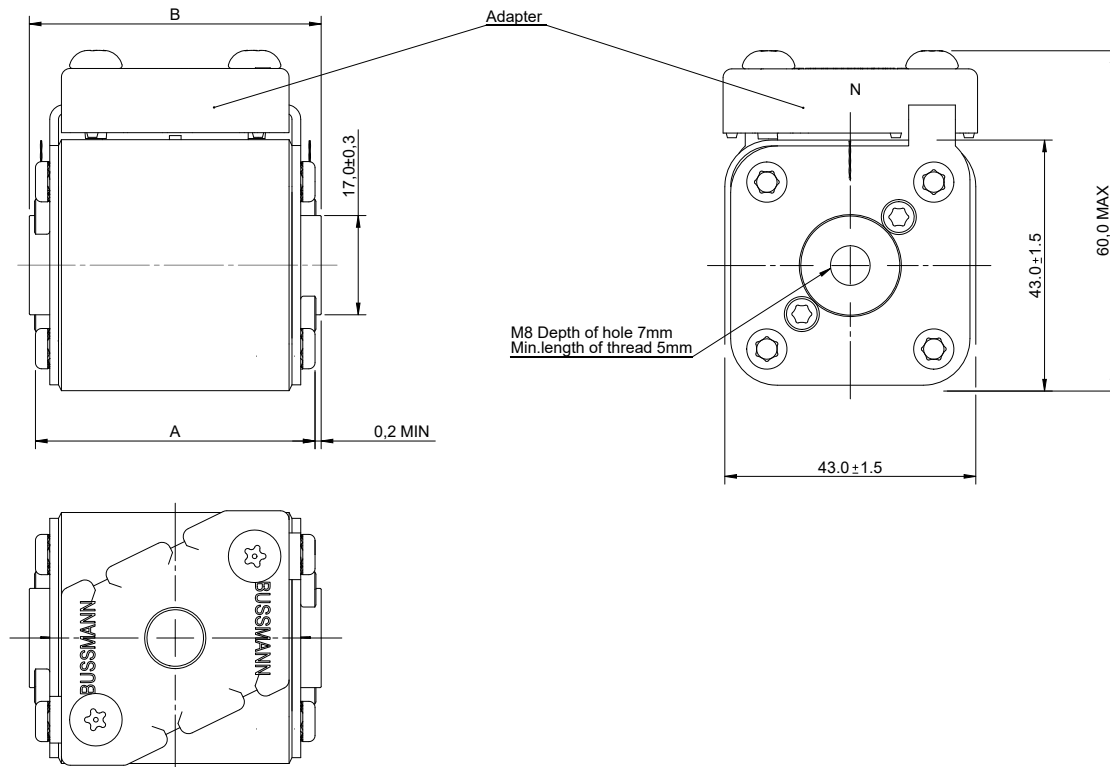

Dimensions (mm) - GKN/75

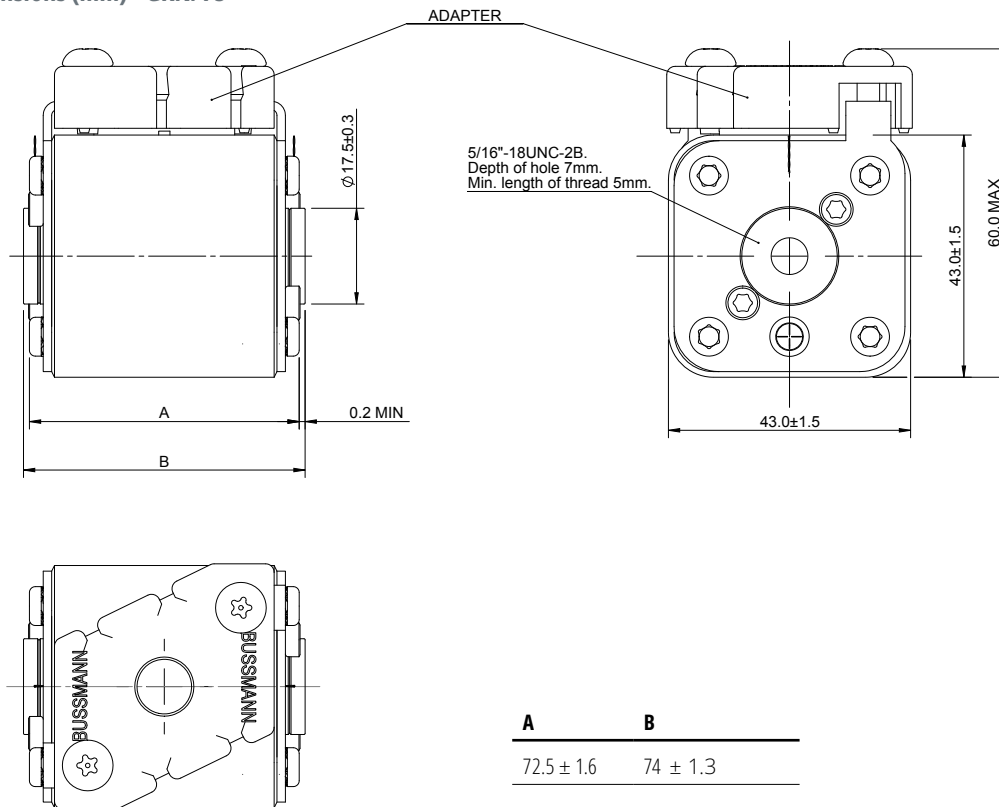

# Square body fuse links

## 800 V d.c. (IEC), 900 V d.c. (UL) - 50 A to 350 A - 180D - Flush end contact fuse body size 1\*

Dimensions (mm) - FU/115

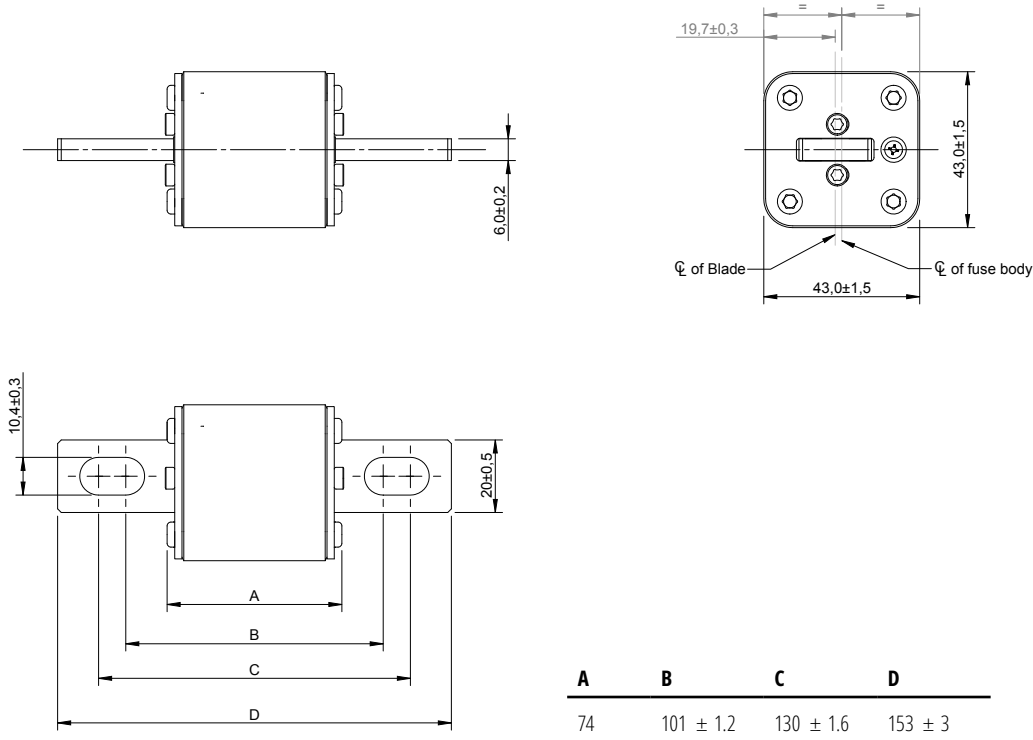

Dimensions (mm) - FKE/115

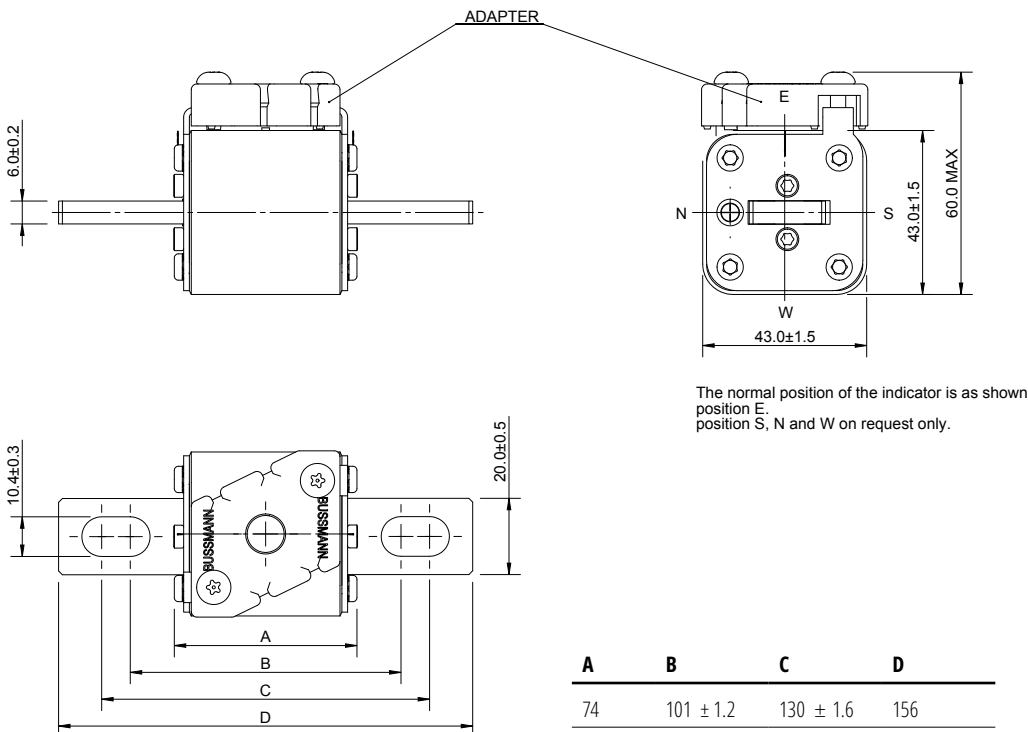

800 V d.c. (IEC), 900 V d.c. (UL) - 50 A to 350 A - 180D - Flush end contact fuse body size 1\*

Time-current curve

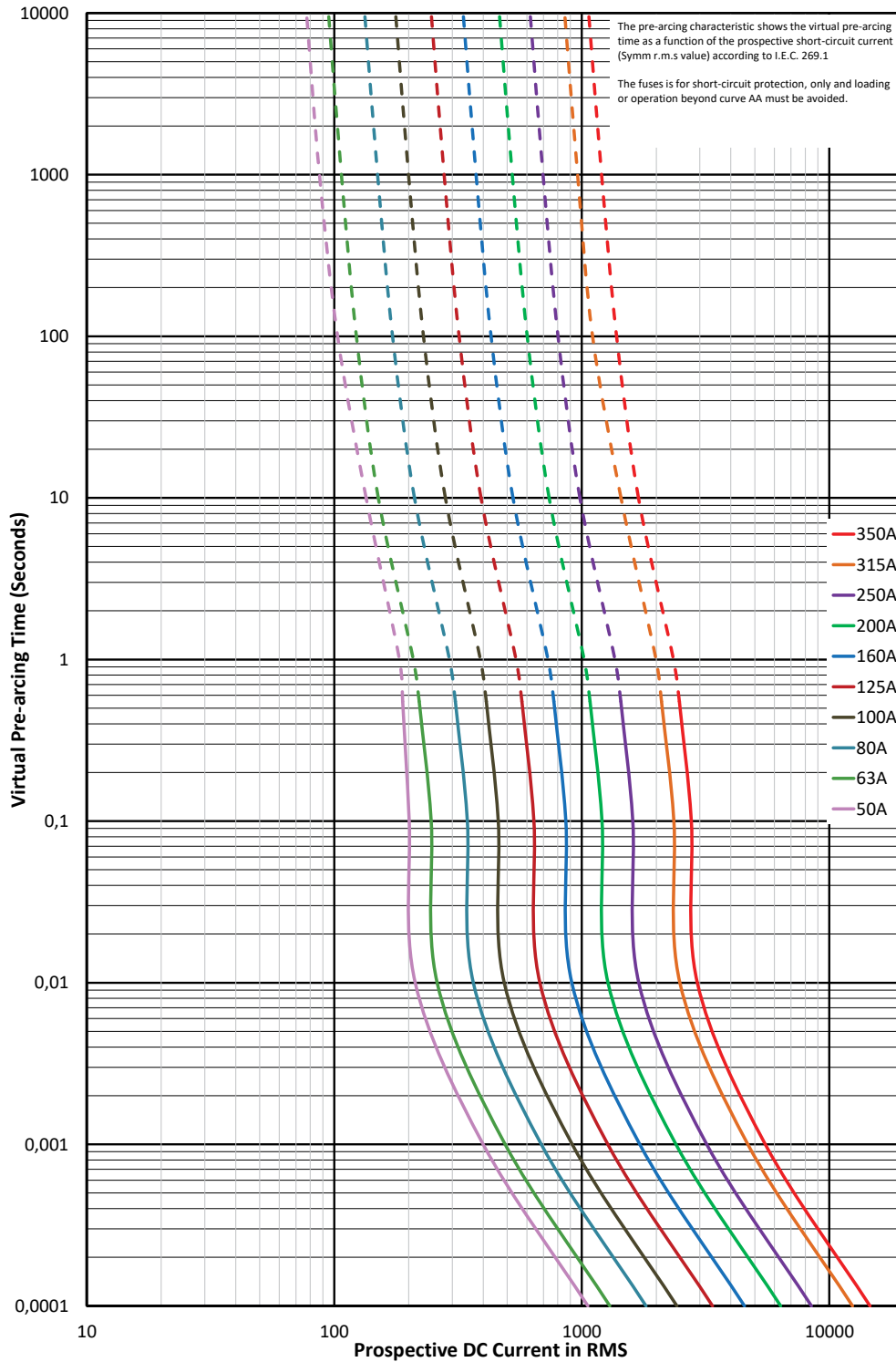

$K_b = 1$   $N = 1,5$

# Square body fuse links

800 V d.c. (IEC), 900 V d.c. (UL) - 50 A to 350 A - 180D - Flush end contact fuse body size 1\*

## Peak let-through curve

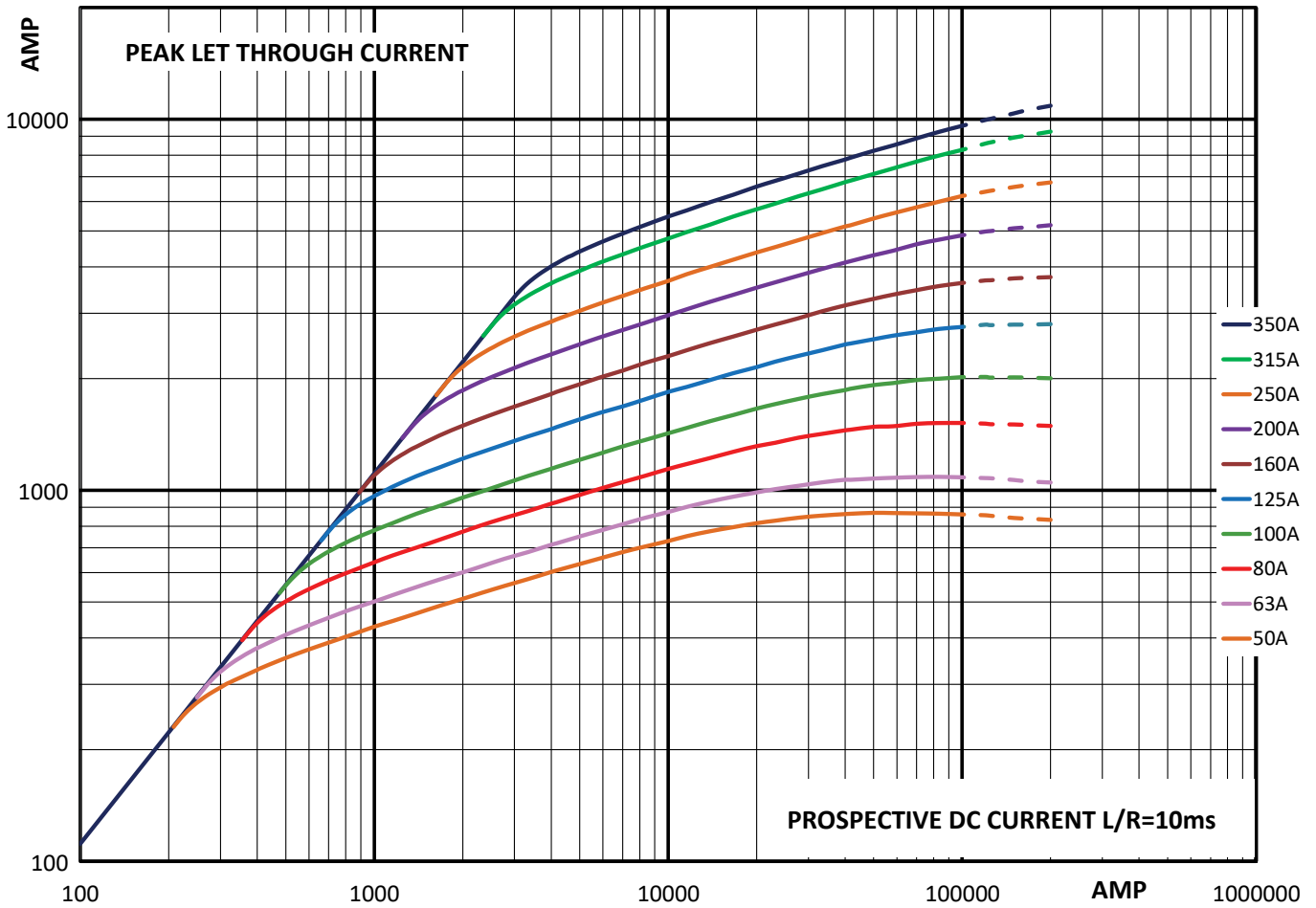

## Watts losses

Watts loss at rated current is given in the electrical characteristics. The curve allows the calculation of the watts losses at load currents lower than the rated current. The correction factor,  $K_p$ , is given as a function of the RMS load current,  $I_b$ , in percent of the rated current.

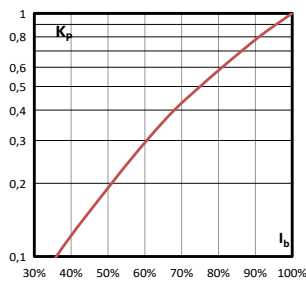

800 V d.c. (IEC), 900 V d.c. (UL) - 160 A to 450 A - 180D - Flush end contact and DIN Fuse body size 1

Specifications

Description

Eaton's Bussmann™ series 800 V d.c./900 V d.c. aR square body fuse links deliver fast, dependable protection for advanced DC systems, including DC common bus, EV charging infrastructure, DC drives, and power conversion applications.

Technical data

- Rated voltage: 800 V d.c. (IEC), 900 V d.c. (UL)
- Rated current: 160 A to 450 A
- Breaking capacity: 100 kA
- Operating class: aR



Standards / Agency information

Designed and tested to IEC 60269 part 4, UL 248-13 Recognised, RoHS compliant

Catalog numbers

Fuse body size	Rated voltage	Rated current (Amps)	Breaking capacity (kA at 10ms)	Pre-arcing I <sup>2</sup> t (A <sup>2</sup> Sec)	Power loss at In (W)	Catalog number					
						Fuse type: BKN/75	Fuse type: BKN/80	Fuse type: GKN/75	Fuse type: 1/110	Fuse type: TN/110	Fuse type: KN/110
1	800 V d.c. (IEC)	160	100	1900	45	180D4388	180D4438	180D4488	180D4138	180D4188	180D4238
	900 V d.c. (UL)	200	100	3800	50	180D4389	180D4439	180D4489	180D4139	180D4189	180D4239
		250	100	7750	60	180D4390	180D4440	180D4490	180D4140	180D4190	180D4240
		315	100	15,000	65	180D4391	180D4441	180D4491	180D4141	180D4191	180D4241
		350	100	20,000	70	180D4392	180D4442	180D4492	180D4142	180D4192	180D4242
		400	100	29,500	75	180D4393	180D4443	180D4493	180D4143	180D4193	180D4243
		450	100	42,000	80	180D4394	180D4444	180D4494	180D4144	180D4194	180D4244

Dimensions (mm) - BKN/75

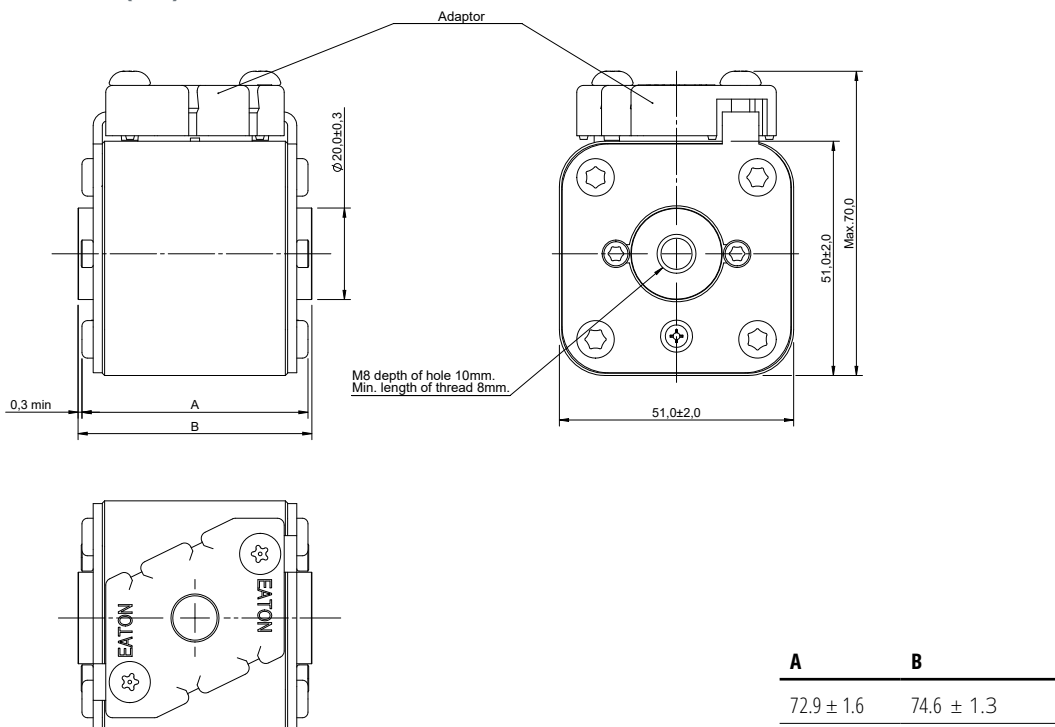

# Square body fuse links

800 V d.c. (IEC), 900 V d.c. (UL) - 160 A to 450 A - 180D - Flush end contact and DIN Fuse body size 1

Dimensions (mm) - BKN/80

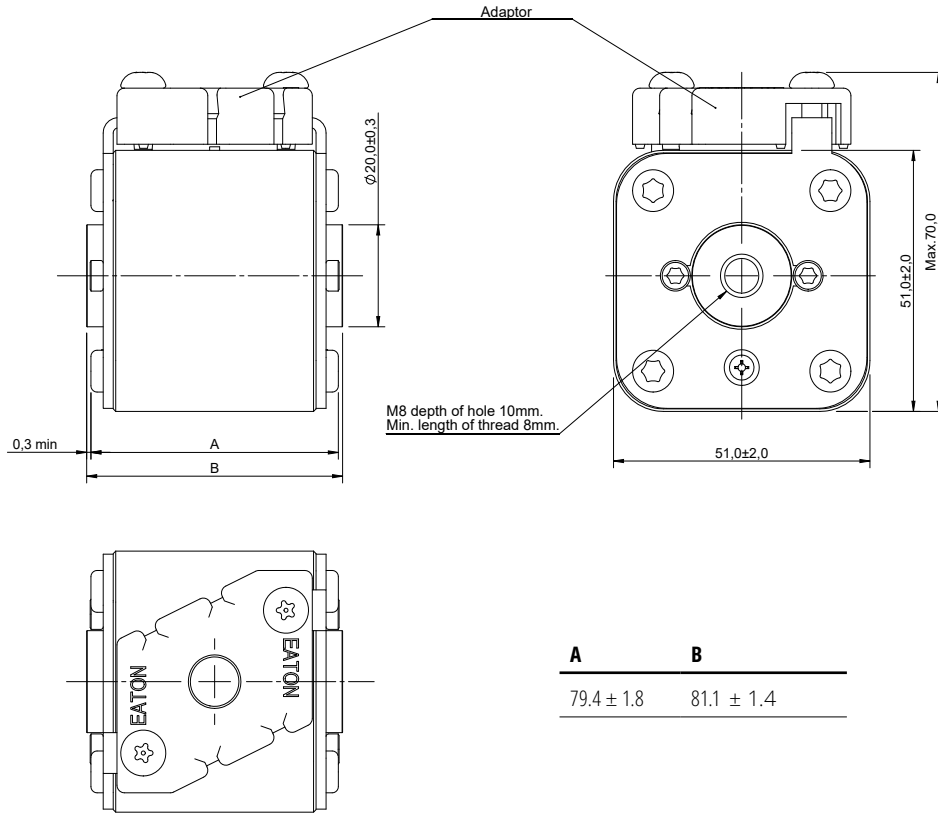

Dimensions (mm) - GKN/75

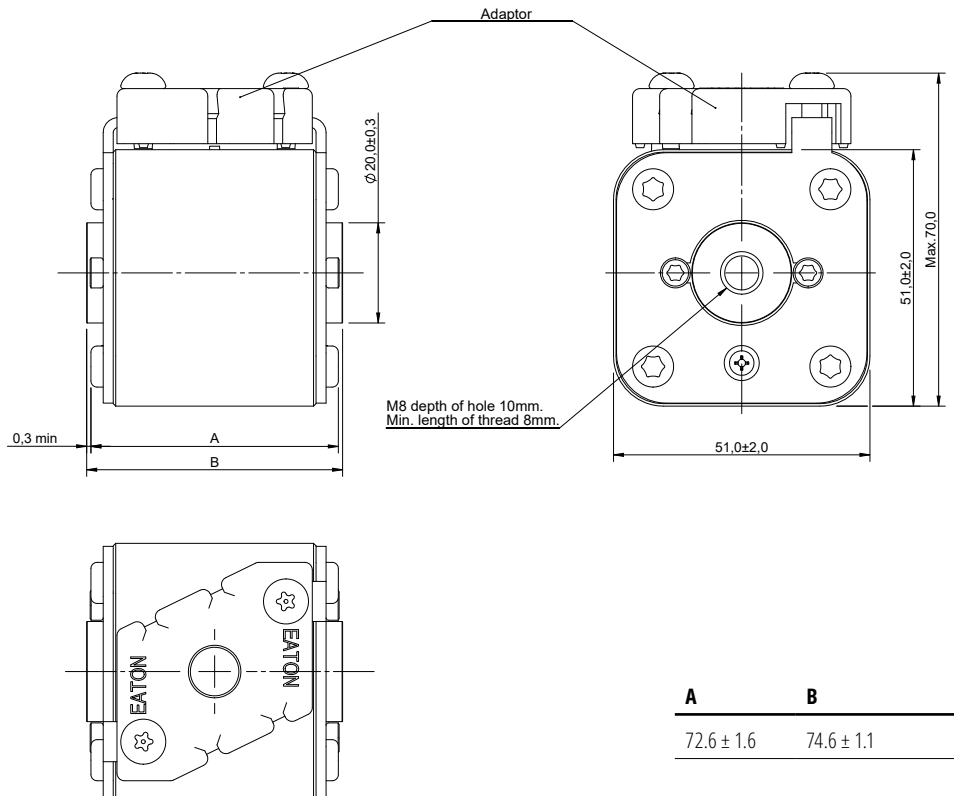

## 800 V d.c. (IEC), 900 V d.c. (UL) - 160 A to 450 A - 180D - Flush end contact and DIN Fuse body size 1

Dimensions (mm) - 1/110 and TN/110

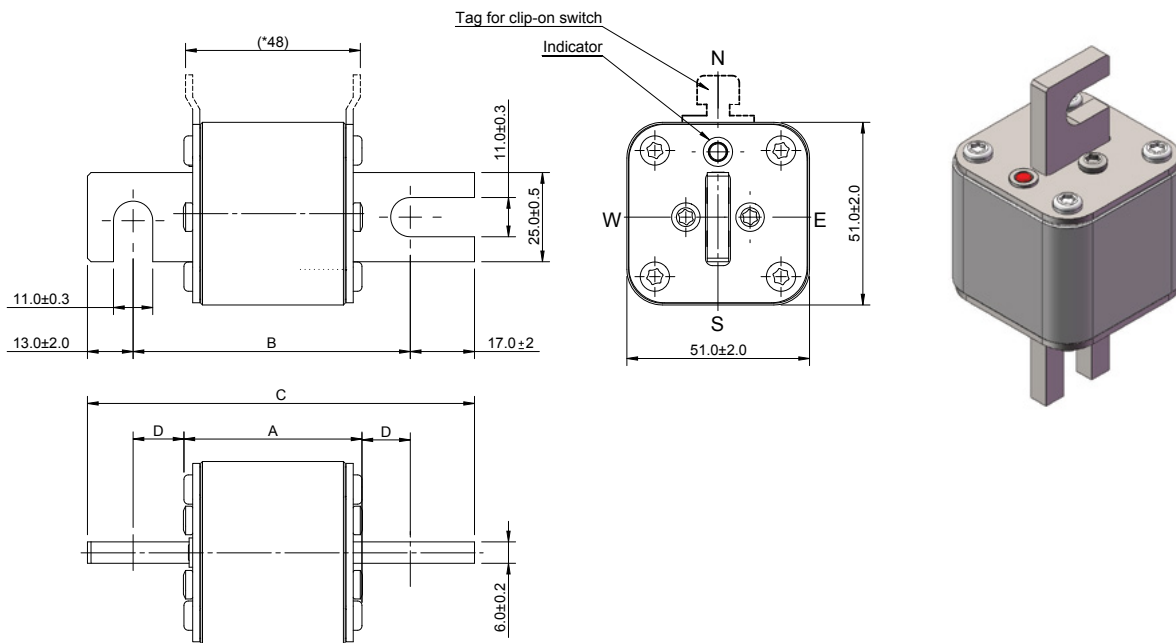

Dimensions (mm) - KN/110

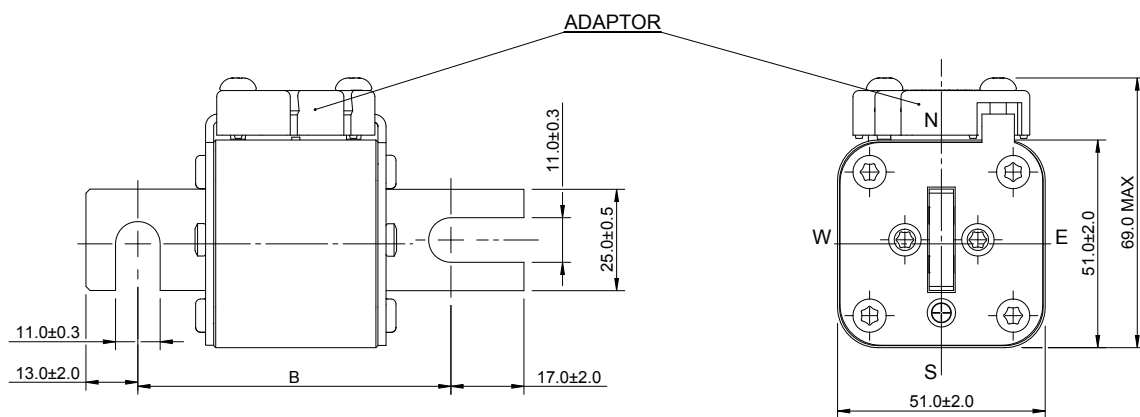

The normal position of the indicator is as shown position N.  
Position S,E and W on request only.

A	B	C	D
$49.6 \pm 1.2$	$108 \pm 1.8$	$138.5 \pm 2.0$	$29 \pm 2$

# Square body fuse links

800 V d.c. (IEC), 900 V d.c. (UL) - 160 A to 450 A - 180D - Flush end contact and DIN Fuse body size 1

## Time-current curve

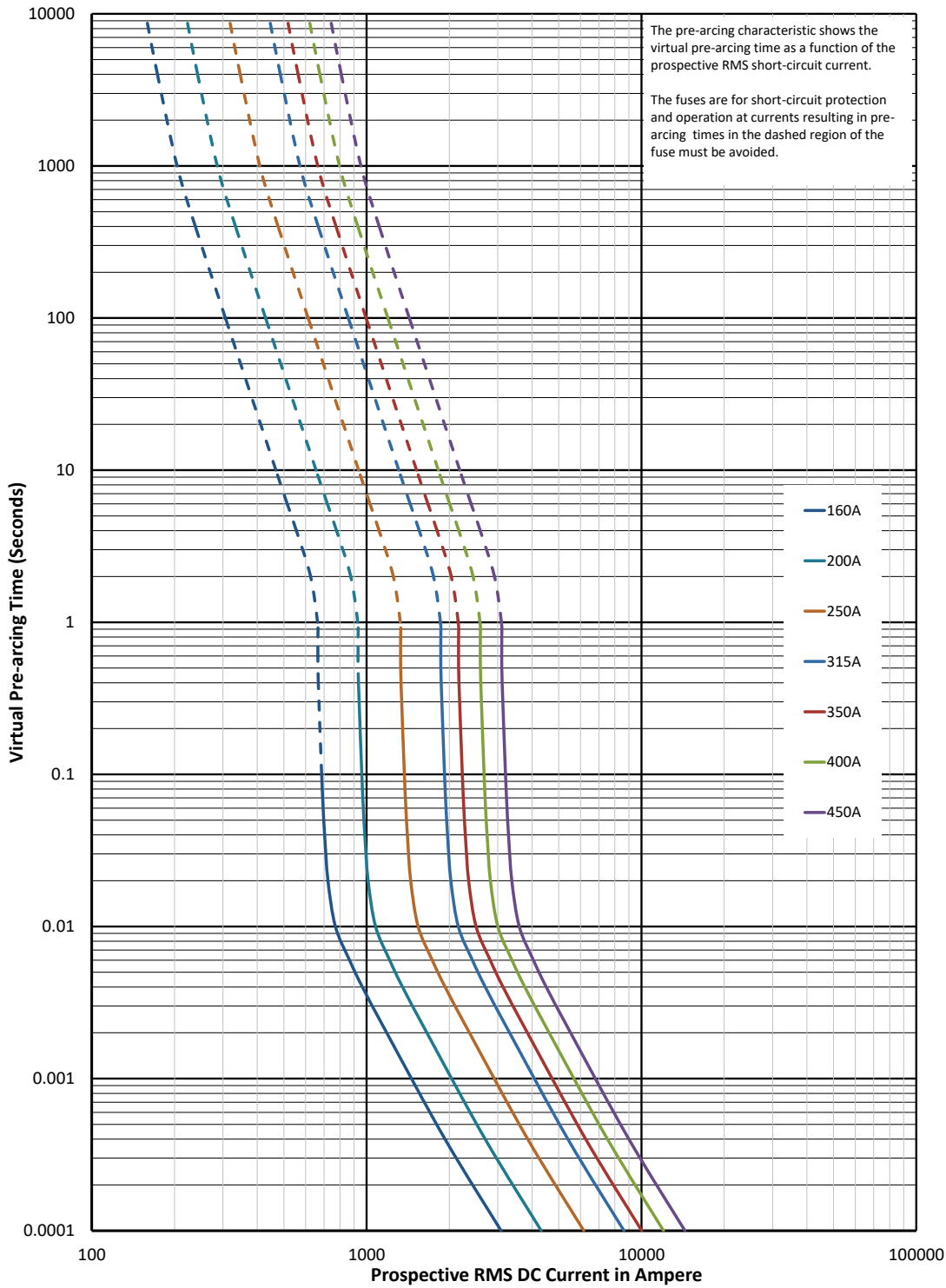

$K_b = 1 \quad N = 1.6$

## 800 V d.c. (IEC), 900 V d.c. (UL) - 160 A to 450 A - 180D - Flush end contact and DIN Fuse body size 1

### Peak let-through curve

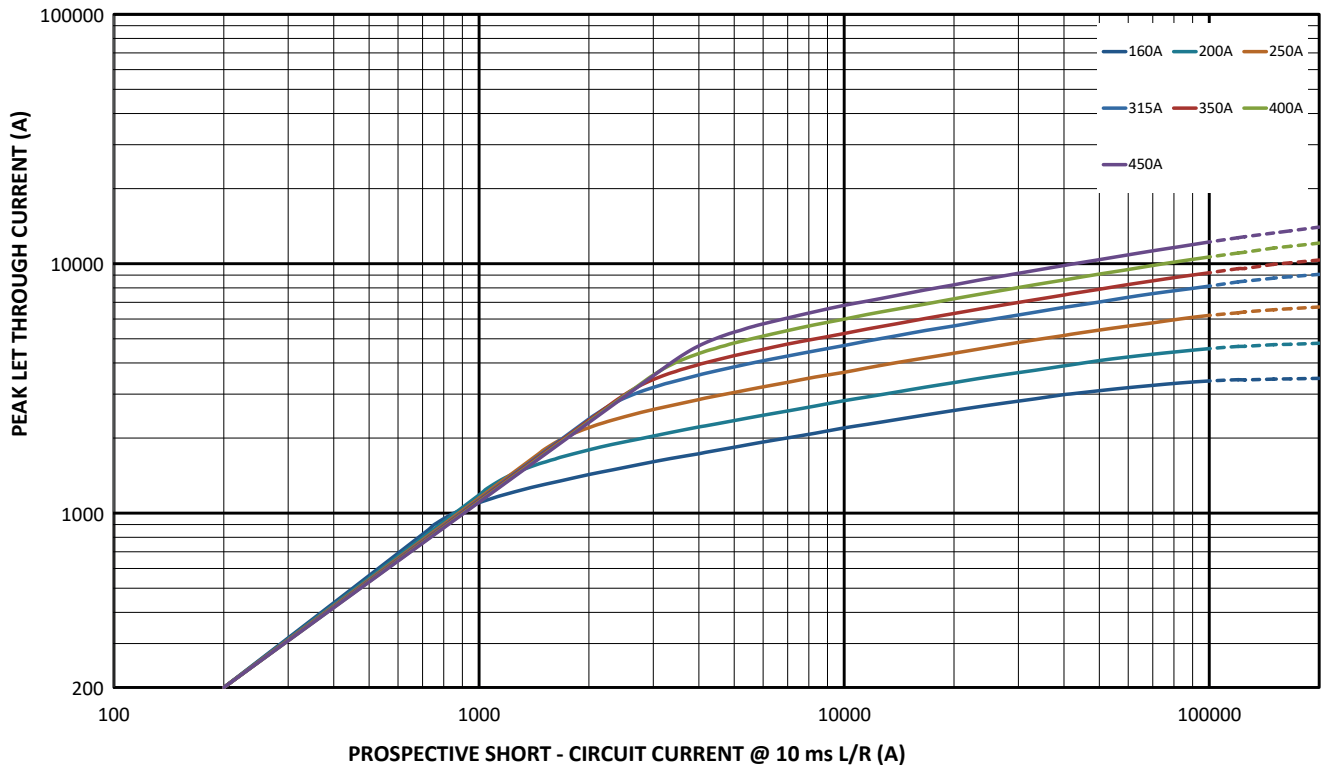

### Watts losses

Watts loss at rated current is given in the electrical characteristics. The curve allows the calculation of the watts losses at load currents lower than the rated current. The correction factor,  $K_p$ , is given as a function of the RMS load current,  $I_b$ , in percent of the rated current.

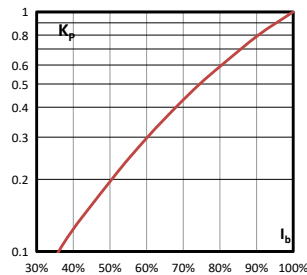

# Square body fuse links

## 800 V d.c. (IEC), 900 V d.c. (UL) - 315 A to 800 A - 180D - Flush end contact and DIN Fuse body size 3

### Specifications

#### Description

Eaton's Bussmann™ series 800 V d.c./900 V d.c. aR square body fuse links deliver fast, dependable protection for advanced DC systems, including DC common bus, EV charging infrastructure, DC drives, and power conversion applications.

#### Technical data

- Rated voltage: 800 V d.c. (IEC), 900 V d.c. (UL)
- Rated current: 315 A to 800 A
- Breaking capacity: 100 kA
- Operating class: aR



#### Standards / Agency information

Designed and tested to IEC 60269 part 4, UL 248-13 Recognised, RoHS compliant

#### Catalog numbers

Fuse body size	Rated voltage	Rated current (Amps)	Breaking capacity (kA at 10ms)	Pre-arcing I <sup>2</sup> t (A <sup>2</sup> Sec)	Power loss at In (W)	Catalog number	
						Fuse type: BKN/80	Fuse type: TN/110
3	800 V d.c. (IEC)	315A	100	9500	85	180D6538	180D6188
	900 V d.c. (UL)	350A	100	13,500	90	180D6539	180D6189
		400A	100	19,500	95	180D6540	180D6190
		450A	100	31,000	100	180D6541	180D6191
		500A	100	39,000	105	180D6542	180D6192
		550A	100	55,000	110	180D6543	180D6193
		630A	100	835,00	115	180D6544	180D6194
		700A	100	115,000	120	180D6545	180D6195
800A	100	205,000	125	180D6546	N/A		

#### Dimensions (mm) - BKN/80

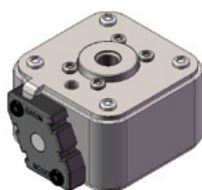
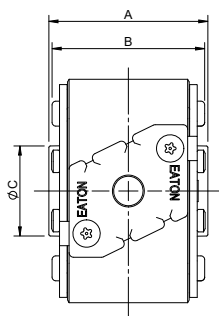
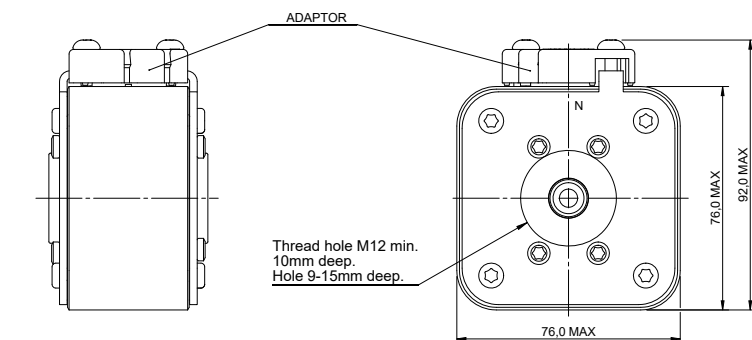

A	B	C
82.4 ± 1.5	82.5	29.6

800 V d.c. (IEC), 900 V d.c. (UL) - 315 A to 800 A - 180D - Flush end contact and DIN Fuse body size 3

Dimensions (mm) - TN/110

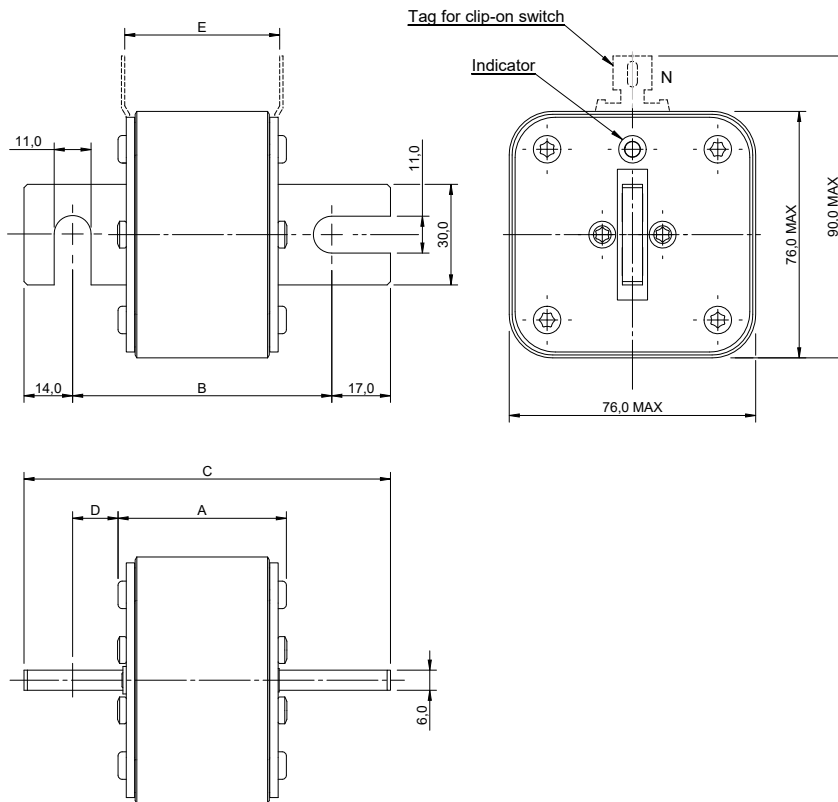

A	B	C	D
82.5	108 ± 2	141	14 ± 2

# Square body fuse links

800 V d.c. (IEC), 900 V d.c. (UL) - 315 A to 800 A - 180D - Flush end contact and DIN Fuse body size 3

Time-current curve

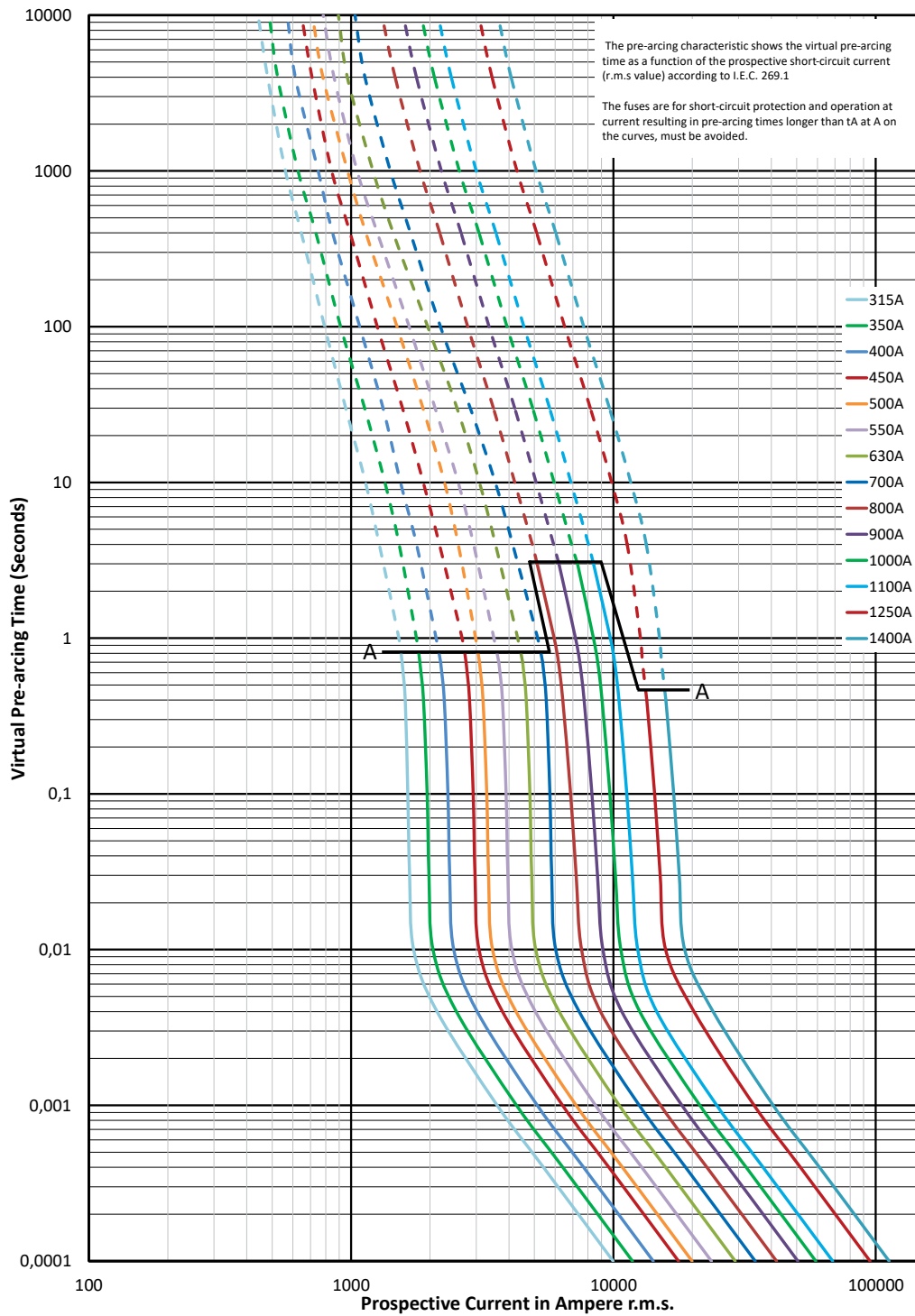

$K_b = 1 \quad N = 1,6$

800 V d.c. (IEC), 900 V d.c. (UL) - 315 A to 800 A - 180D - Flush end contact and DIN Fuse body size 3

Peak let-through curve

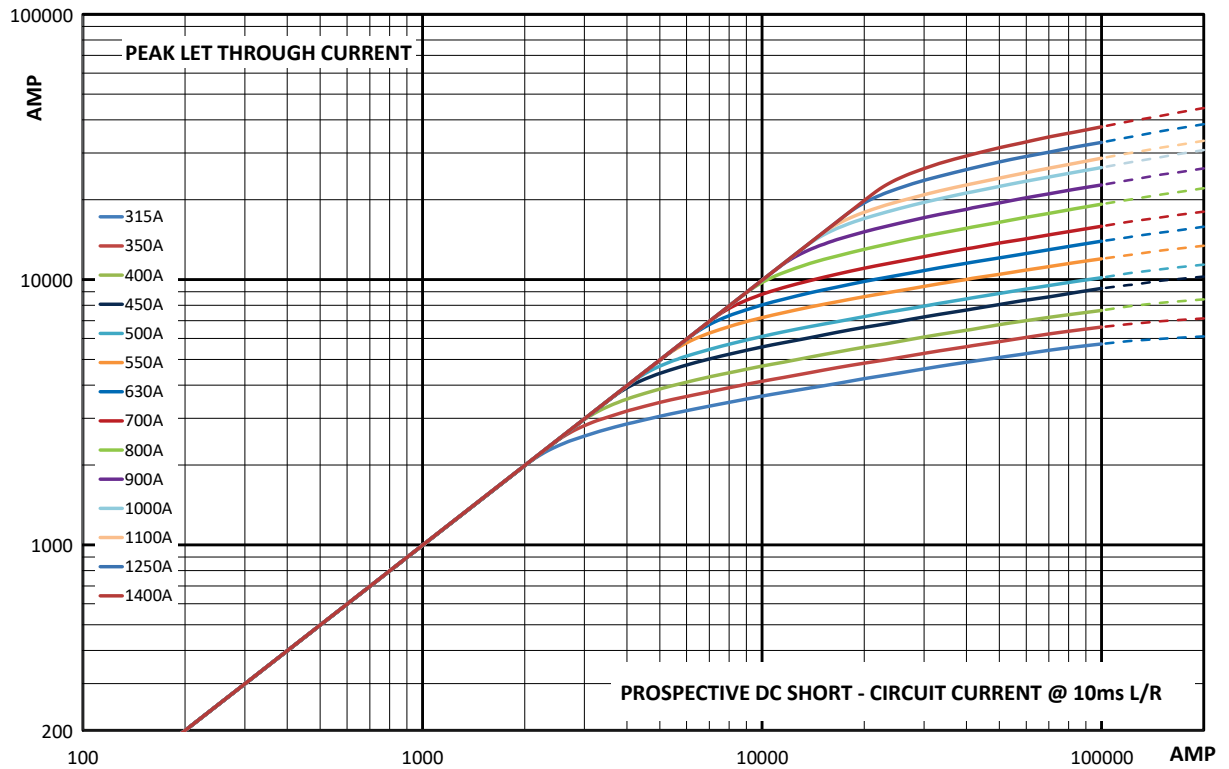

Watts losses

Watts loss at rated current is given in the electrical characteristics. The curve allows the calculation of the watts losses at load currents lower than the rated current. The correction factor,  $K_p$ , is given as a function of the RMS load current,  $I_b$ , in percent of the rated current.

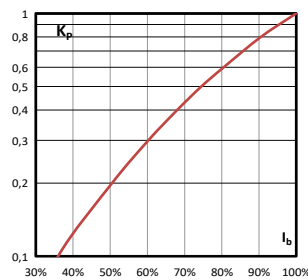

# Square body fuse links

## 800 V d.c. (IEC), 900 V d.c. (UL) - 1000 A to 1600 A - 180D - Flush end contact fuse body size 23

### Specifications

#### Description

Eaton's Bussmann series 800 V d.c./900 V d.c. gR square body fuse links deliver fast, dependable protection for advanced DC systems, including DC common bus, EV charging infrastructure, DC drives, and power conversion applications.

#### Technical data

- Rated voltage: 800 V d.c. (IEC), 900 V d.c. (UL)
- Rated current: 1000 A to 1600 A
- Breaking capacity: 100 kA
- Operating class: gR



#### Standards / Agency information

Designed and tested to IEC 60269 part 4, UL 248-13 Recognised, RoHS compliant

#### Catalog numbers

Fuse body size	Rated voltage	Rated current (Amps)	Breaking capacity (kA)	Minimum Pre-arcing I <sup>2</sup> t (A <sup>2</sup> Sec)	Maximum Clearing Integral A2s @ 800Vdc 10ms L/R	Minimum Breaking Current (A) @ 800VDC	Power loss at I <sub>n</sub> (W)	Catalog number
23	800 V d.c. (IEC)	1000	100	476,300	1,488,000	2000	247	180D2017
	900 V d.c. (UL)	1250	100	694,000	2,168,000	2500	349	180D2018
		1400	100	1,071,600	3,357,000	2800	353	180D2019
		1500	100	1,230,200	3,842,000	3000	377	180D2020
		1600	100	1,399,700	4,371,000	3200	383	180D2021

#### Dimensions (mm)

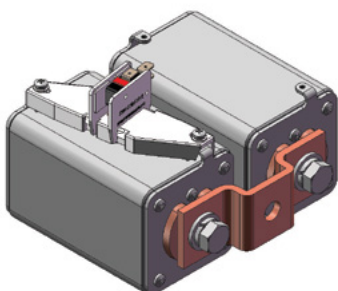
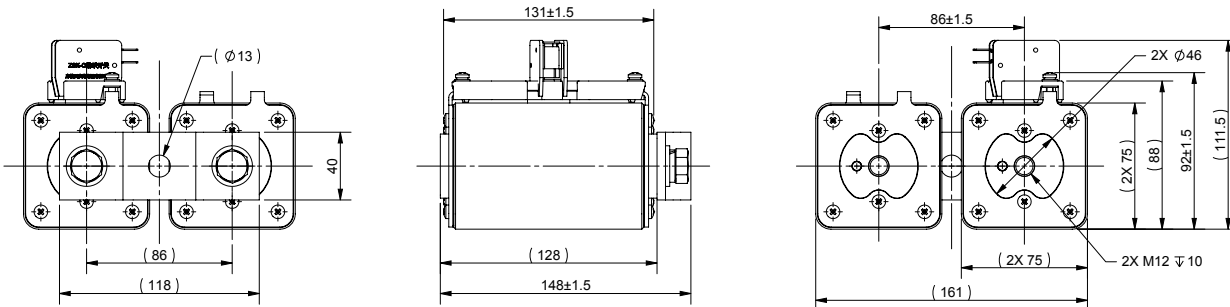

Data sheet: 5785657

800 V d.c. (IEC), 900 V d.c. (UL) - 1000 A to 1600 A - 180D - Flush end contact fuse body size 23

Time-current curve

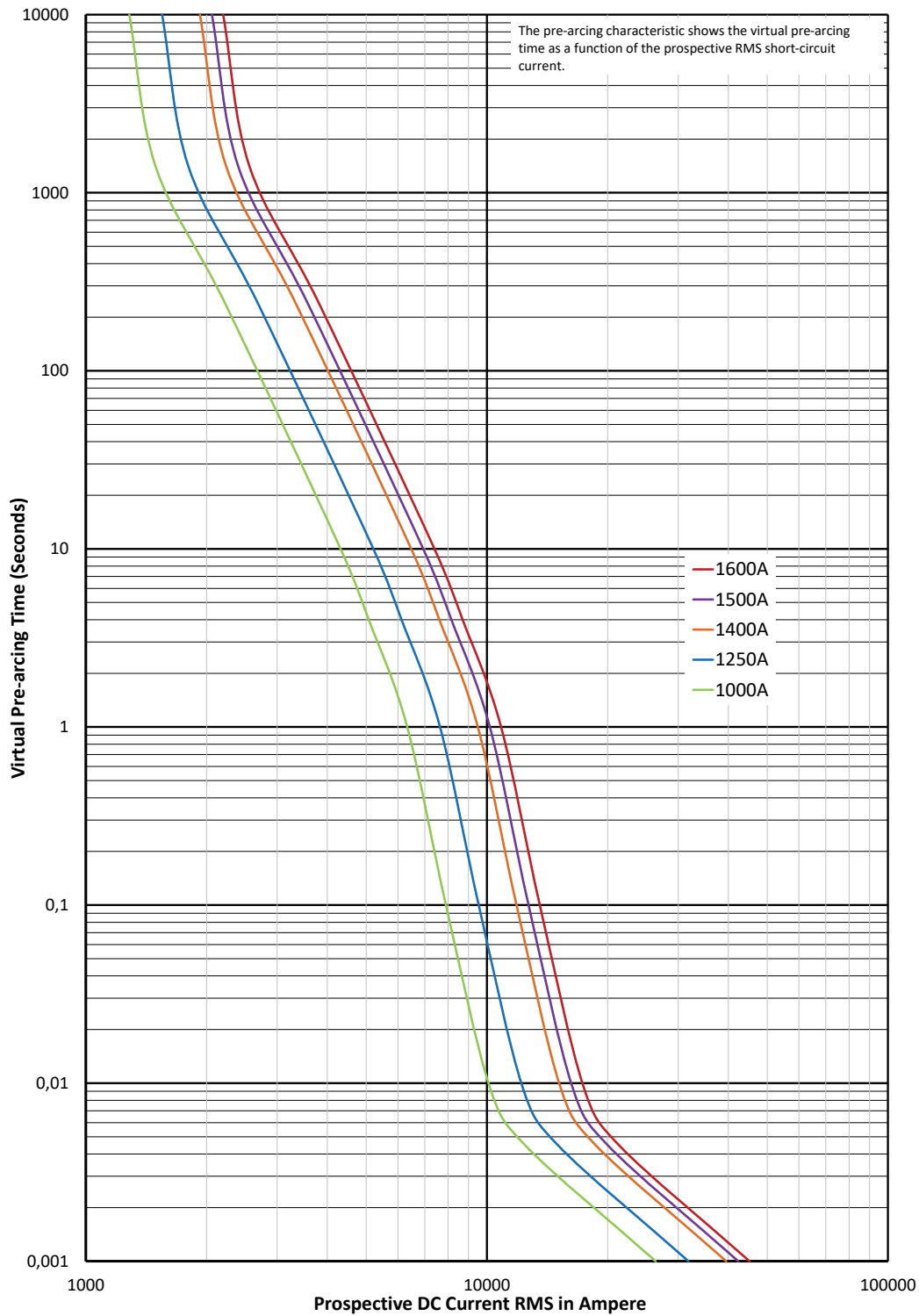

$K_b = 1$   $N = 1,6$

# Square body fuse links

800 V d.c. (IEC), 900 V d.c. (UL) - 1000 A to 1600 A - 180D - Flush end contact fuse body size 23

## Peak let-through curve

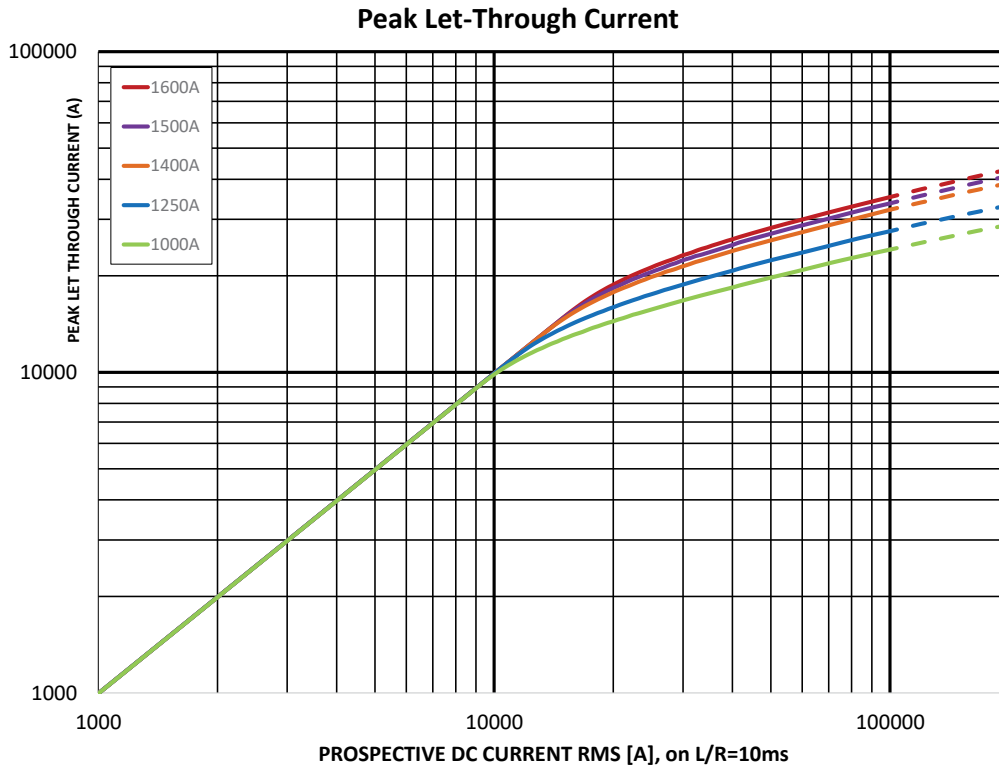

### Total clearing I<sup>2</sup>t

The total clearing I<sup>2</sup>t at rated voltage and tested DC time constant are given in electrical characteristics. For other voltages the clearing I<sup>2</sup>t is found by multiplying by correction factor, K, given as a function of applied working voltages, E.

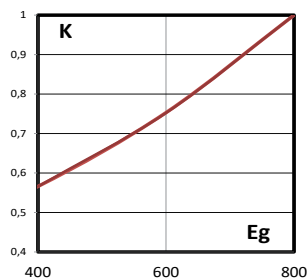

### Watts losses

Watts loss at rated current is given in the electrical characteristics. The curve allows the calculation of the watts losses at load currents lower than the rated current. The correction factor, K<sub>p</sub>, is given as a function of the RMS load current, I<sub>b</sub>, in percent of the rated current.

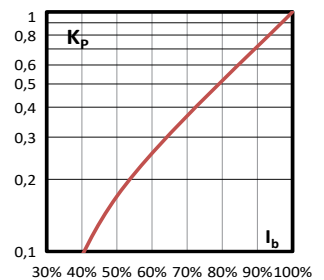

800 V d.c. (IEC), 900 V d.c. (UL) - 630 A to 2200 A - 180D - Flush end contact fuse body size 23

Specifications

Description

Eaton's Bussmann series 800 V d.c./900 V d.c. aR square body fuse links deliver fast, dependable protection for advanced DC systems, including DC common bus, EV charging infrastructure, DC drives, and power conversion applications.

Technical data

- Rated voltage: 800 V d.c. (IEC), 900 V d.c. (UL)
- Rated current: 630 A to 2200 A
- Breaking capacity: 100 kA
- Operating class: aR



Standards / Agency information

Designed and tested to IEC 60269 part 4, UL 248-13 Recognised, RoHS compliant

Catalog numbers

Fuse body size	Rated voltage	Rated current (Amps)	Breaking capacity (kA at 10ms)	Pre-arcing I <sup>2</sup> t (A <sup>2</sup> Sec)	Power loss at I <sub>n</sub> (W)	Catalog number	
						Fuse type: BKN/75	Fuse type: BKN/80
23	800 V d.c. (IEC)	630	100	38,000	185	180D6785	N/A
	900 V d.c. (UL)	700	100	54,000	195	180D6786	N/A
		800	100	78,000	205	180D6787	N/A
		900	100	120,000	215	180D6806	N/A
		1000	100	155,000	225	180D6788	N/A
		1100	100	220,000	235	180D6789	N/A
		1250	100	330,000	245	180D6790	N/A
		1400	100	460,000	255	180D6791	N/A
		2000	100	1,800,000	285	N/A	180D6794
	2200	100	2,300,000	300	N/A	180D6827	

Dimensions (mm)

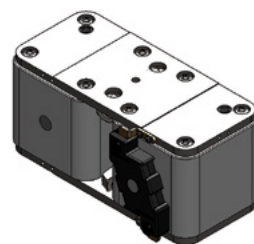
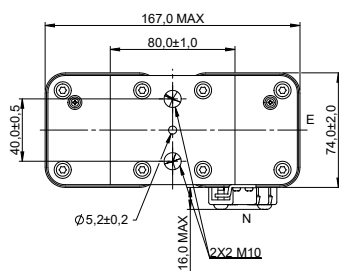
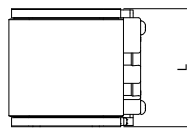
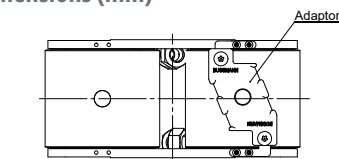

	L
BKN/75	75 ± 1
BKN/80	82 ± 1.1

The normal Position of the indicator is as shown position N, Position E only on request.

# Square body fuse links

## 800 V d.c. (IEC), 900 V d.c. (UL) - 630 A to 2200 A - 180D - Flush end contact fuse body size 23

### Time-current curve

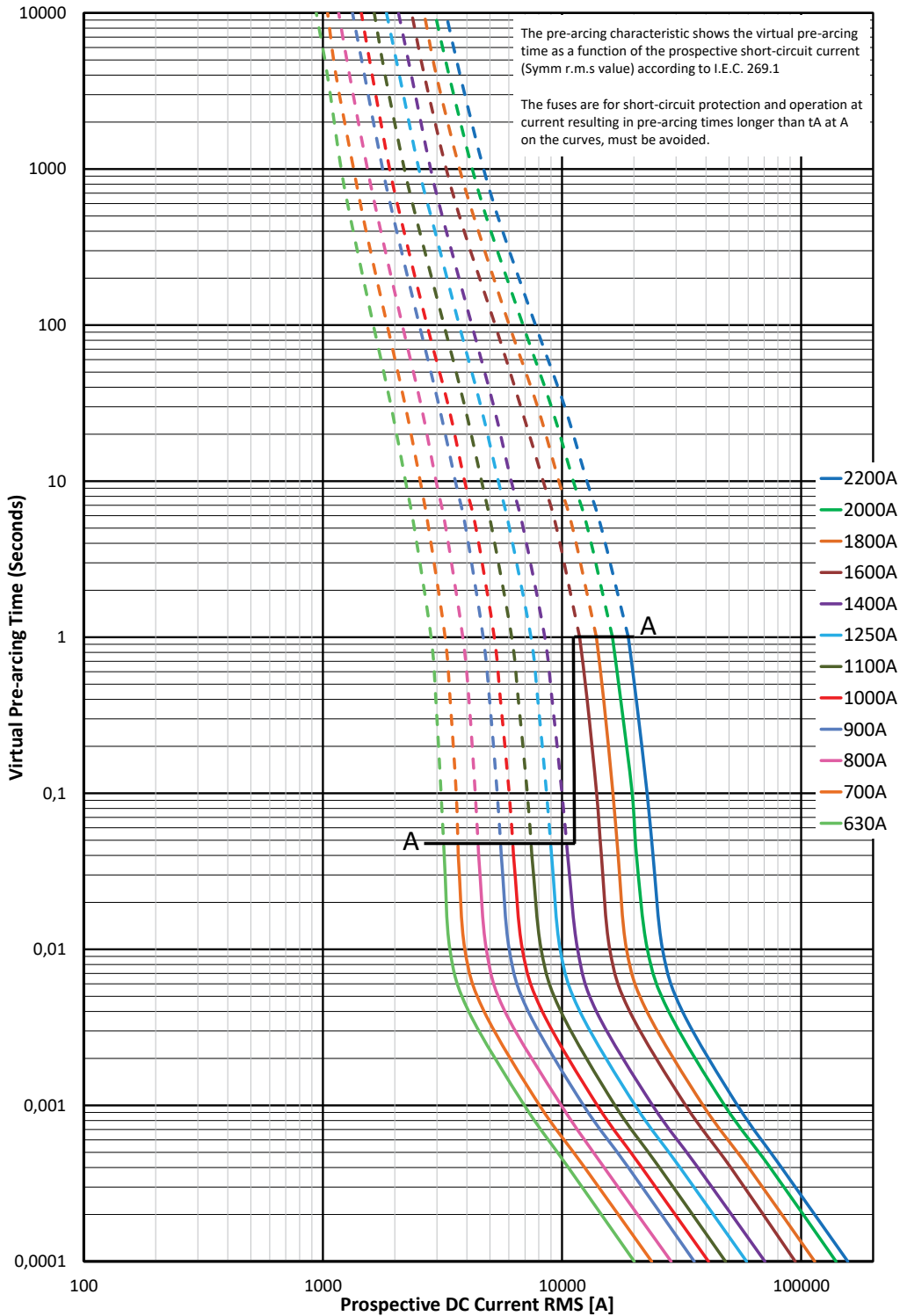

800 V d.c. (IEC), 900 V d.c. (UL) - 630 A to 2200 A - 180D - Flush end contact fuse body size 23

Peak let-through curve

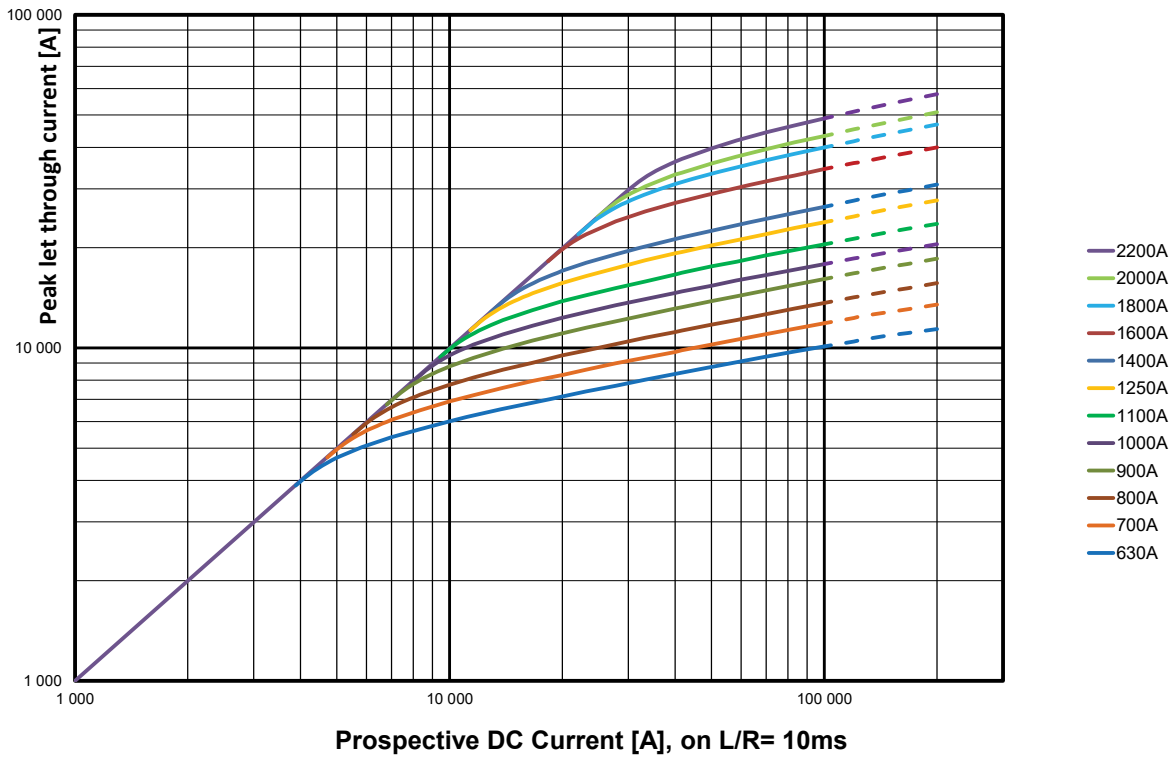

Watts losses

Watts loss at rated current is given in the electrical characteristics. The curve allows the calculation of the watts losses at load currents lower than the rated current. The correction factor,  $K_p$ , is given as a function of the RMS load current,  $I_b$ , in percent of the rated current.

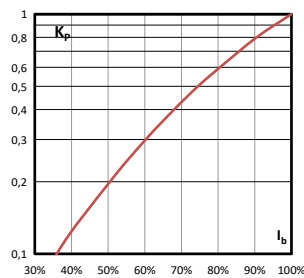

# Square body fuse links

## 1000 V d.c. (IEC) - 63 A to 400 A - BSF-NH - NH Style

### Specifications

#### Description

Eaton's Bussmann series NH battery storage fuses are specifically designed to protect and isolate battery array combiners and disconnects. These fuse links are capable of interrupting low overcurrents associated with faulted battery storage systems (reverse current, multi-array fault).

#### Technical data

- Rated voltage: 1000 V d.c.
- Rated current: 63 A to 400 A
- Operating class: gBat proposed for full range fuse links for protection of battery storage systems
- Breaking capacity: 100 kA
- Time constant: 4.5ms at 100 kA

#### Microswitches

- For bladed fuse links only
  - 170H0236
  - 170H0238

#### Fuse holders

- For bladed fuse links only
  - SD1-D-PV
  - SD2-D-PV
  - SD3-D-PV

#### Standards / Agency information

IEC 60269-7



### Catalog numbers

Fuse link body size	Rated voltage	Rated current (Amps)	I <sup>2</sup> t (A <sup>2</sup> Sec)		Watts loss (W)		Catalog numbers	
			Pre-arcing	Total at 1000 V d.c.	0.7 I <sub>n</sub>	I <sub>n</sub>	Bladed version	Bolted version
1	1000 V d.c.	63	470	4300	5	12	BSF-063G-NH110	BSF-063G-NH110-B
		80	640	5760	6	15.5	BSF-080G-NH110	BSF-080G-NH110-B
		100	1300	11,700	7	16.5	BSF-100G-NH110	BSF-100G-NH110-B
		125	2600	23,400	7	17.5	BSF-125G-NH110	BSF-125G-NH110-B
		160	5200	46,800	11	27.5	BSF-160G-NH110	BSF-160G-NH110-B
		200	10,200	82,000	10	25	BSF-200G-NH110	BSF-200G-NH110-B
2	1000 V d.c.	160	4600	37,000	11	28	BSF-160G-NH210	BSF-160G-NH210-B
		200	9500	76,000	13	32	BSF-200G-NH210	BSF-200G-NH210-B
		250	17,000	136,000	15	38	BSF-250G-NH210	BSF-250G-NH210-B
3	1000 V d.c.	315	32,000	260,000	18	44	BSF-315G-NH310	BSF-315G-NH310-B
		355	44,500	370,000	18	46	BSF-355G-NH310	BSF-355G-NH310-B
		400	67,500	550,000	20	50	BSF-400G-NH310	BSF-400G-NH310-B

1000 V d.c. (IEC) - 63 A to 400 A - BSF-NH - NH Style

Dimensions (mm) - Size 1, bladed

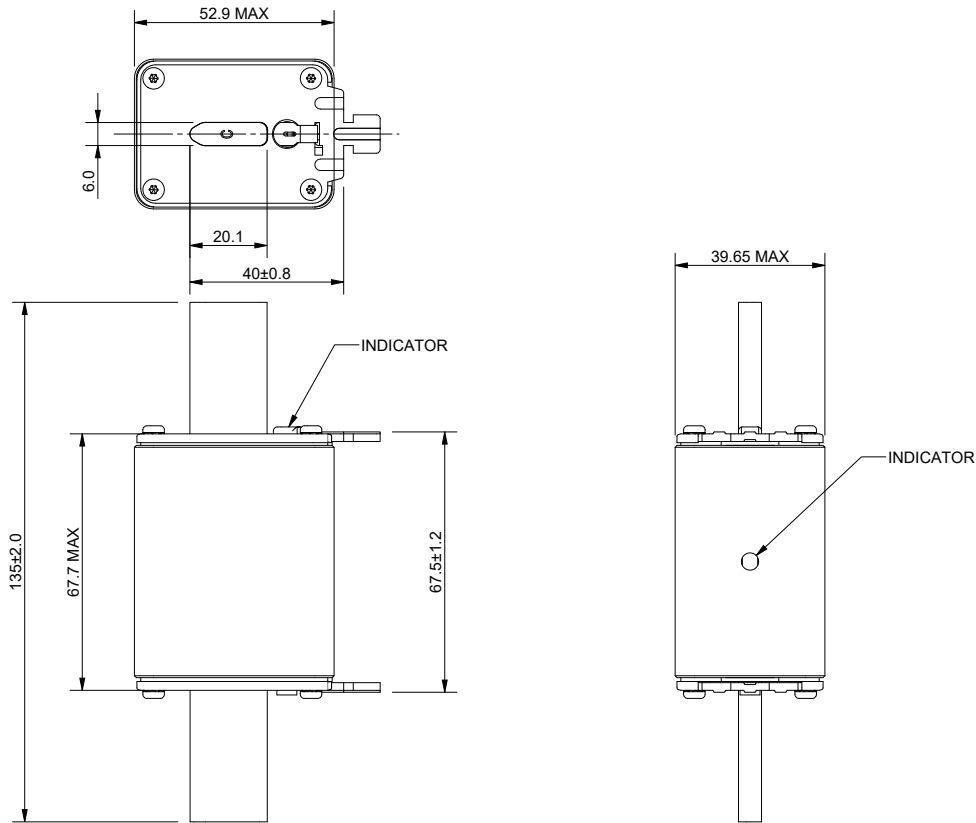

Dimensions (mm) - Size 2, bladed

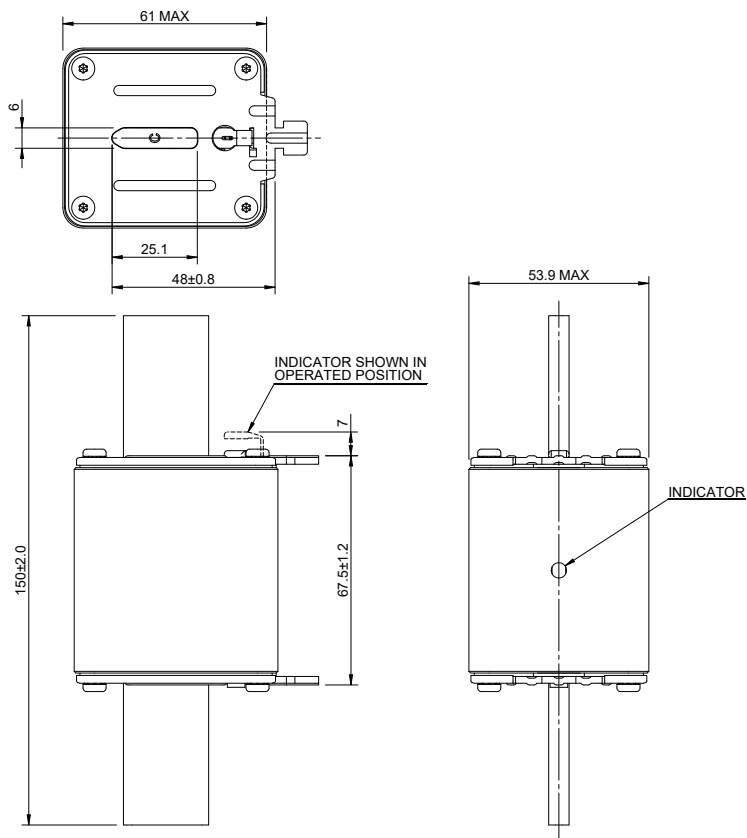

Data sheet: 135001

# Square body fuse links

## 1000 V d.c. (IEC) - 63 A to 400 A - BSF-NH - NH Style

### Dimensions (mm) - Size 3, bladed

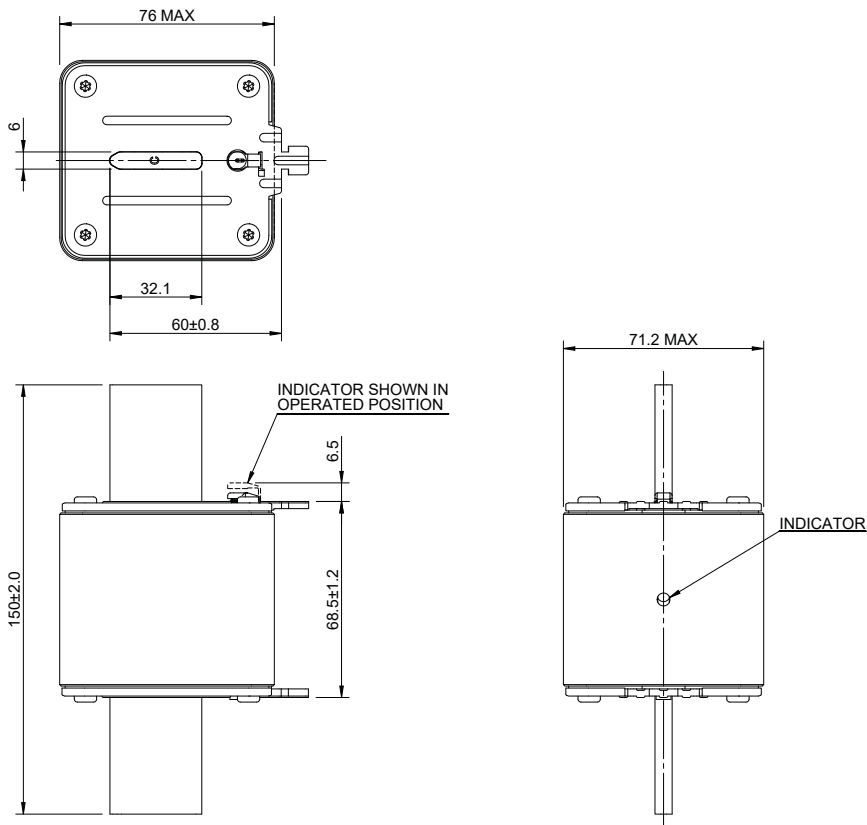

### Dimensions (mm) - Size 1, bolted

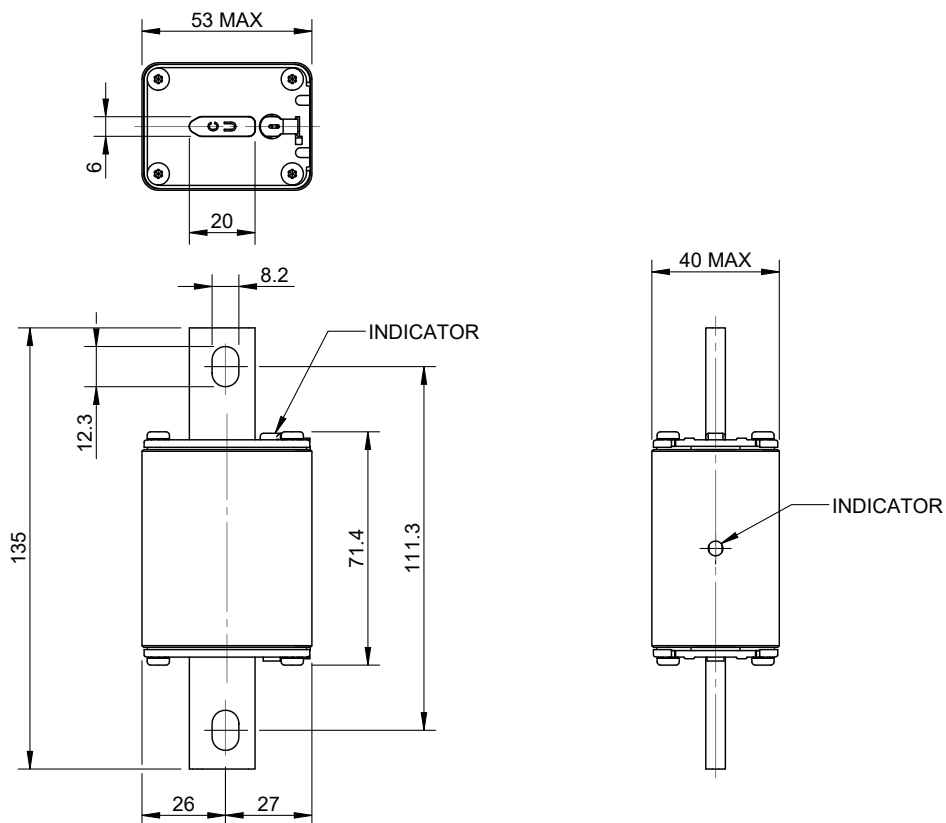

1000 V d.c. (IEC) - 63 A to 400 A - BSF-NH - NH Style

Dimensions (mm)- Size 2, bolted

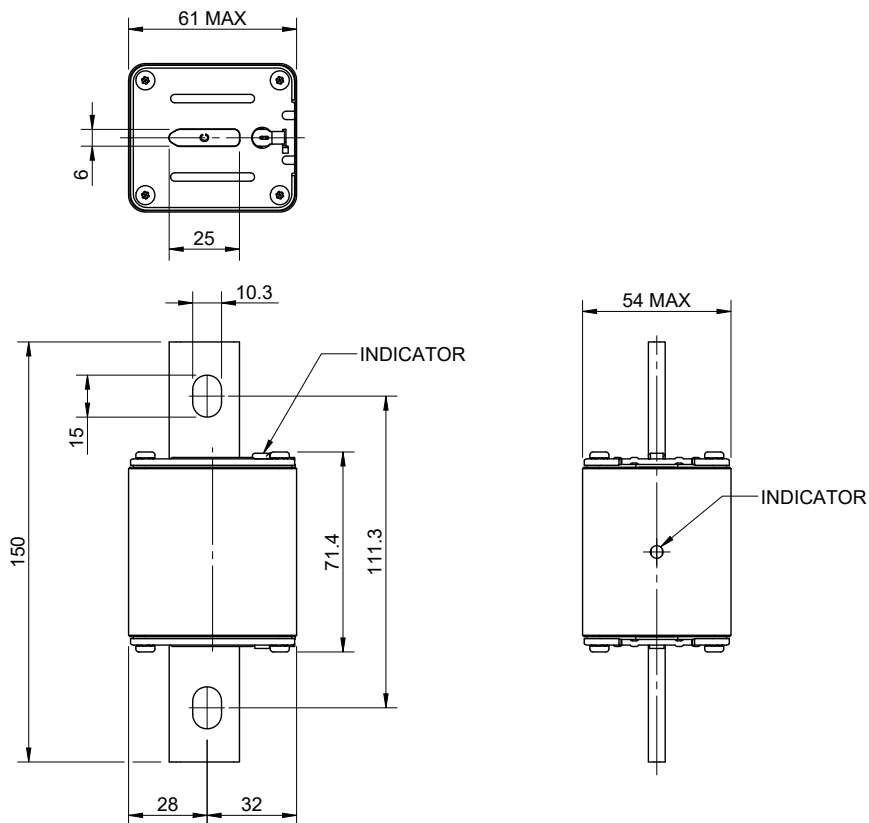

Dimensions (mm) - Size 3, bolted

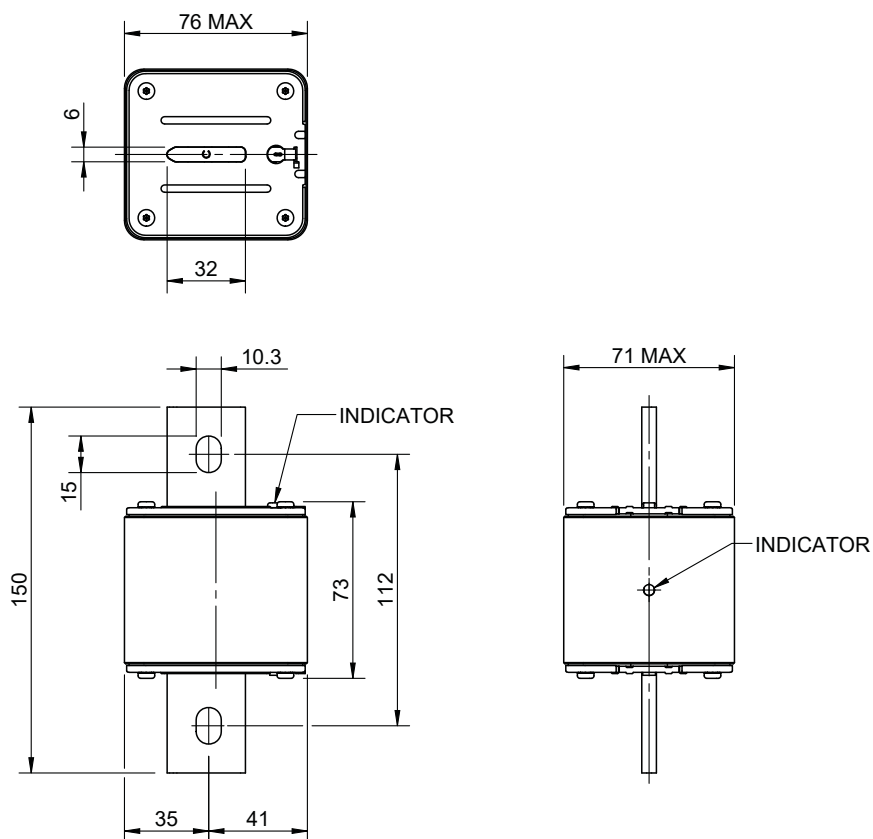

# Square body fuse links

## 1000 V d.c. (IEC) - 63 A to 400 A - BSF-NH - NH Style

Time-current curve - Size 1, 63 A to 200 A

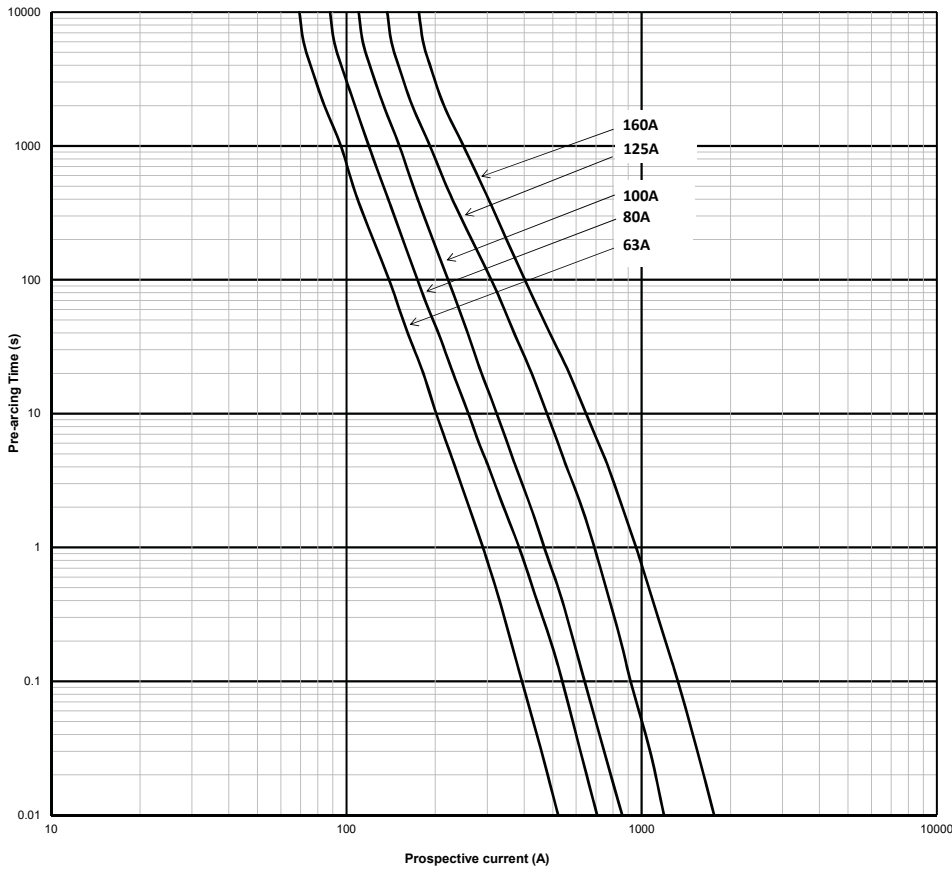

Time-current curve - Size 2, 160 A to 250 A

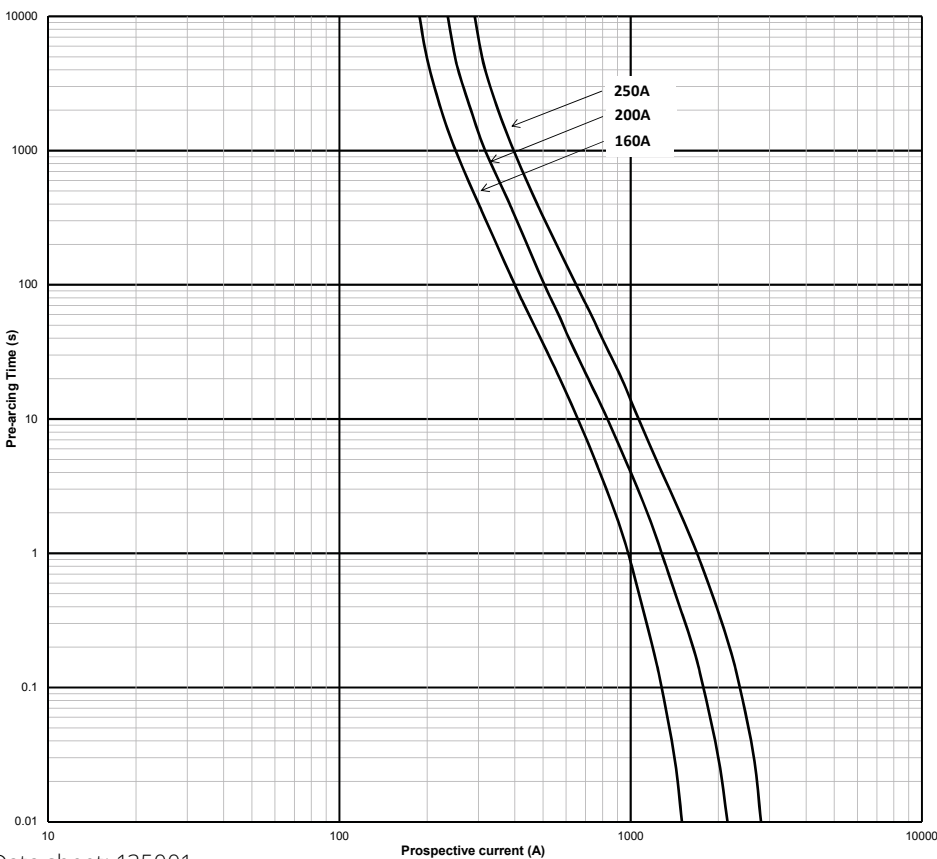

Data sheet: 135001

1000 V d.c. (IEC) - 63 A to 400 A - BSF-NH - NH Style

Time-current curve - Size 3, 315 A to 400 A

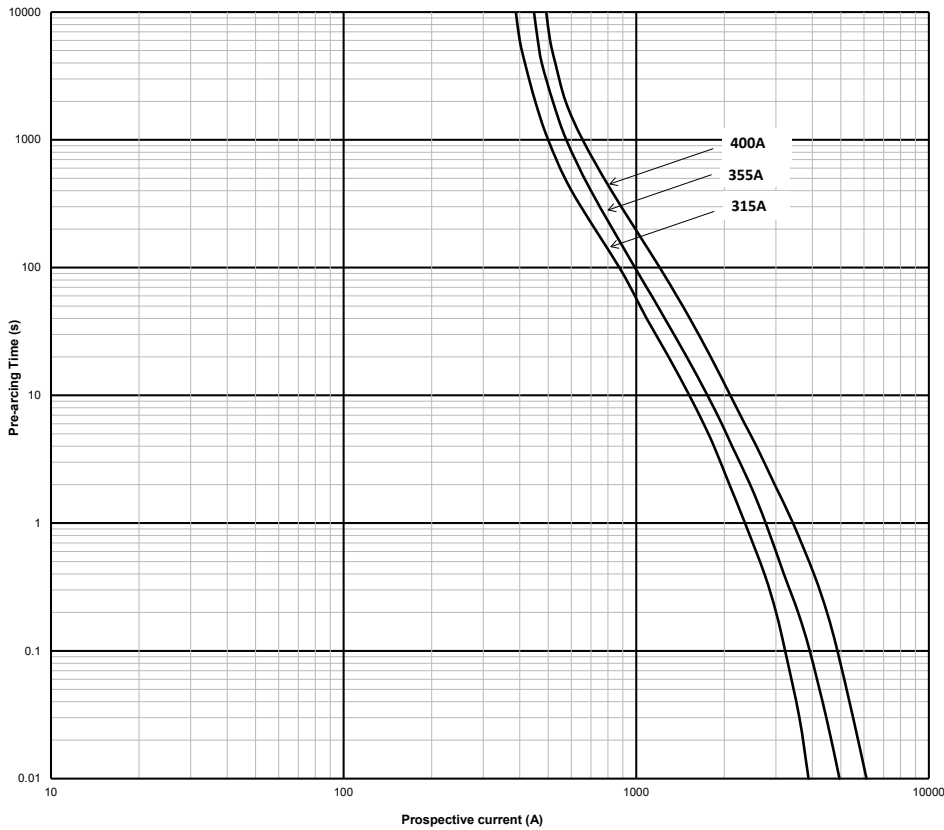

Temperature derating

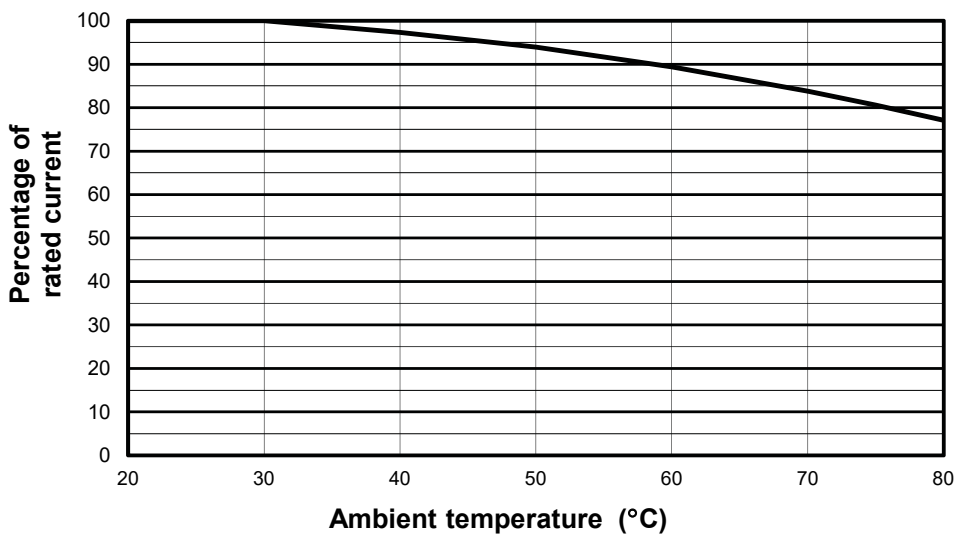

(The ambient temperature is that local to the fuse link)

# Square body fuse links

## 1000 V d.c. (IEC/UL) - 250 A to 550 A - 180D - Flush end contact fuse body size 2

### Specifications

#### Description

Eaton's Bussmann series 1000 V d.c. aR square body fuse links deliver fast, dependable protection for advanced DC systems, including DC common bus, EV charging infrastructure, DC drives, and power conversion applications.

#### Technical data

- Rated voltage: 1000 V d.c. (IEC/UL)
- Rated current: 250 A to 550 A
- Breaking capacity: 100 kA
- Operating class: aR



#### Standards / Agency information

Designed and tested to IEC 60269 part 4, UL 248-13 Recognised, RoHS compliant

#### Catalog numbers

Fuse body size	Rated voltage	Rated current (Amps)	Breaking capacity (kA at 10ms)	Pre-arcing I <sup>2</sup> t (A <sup>2</sup> Sec)	Power loss at I <sub>n</sub> (W)	Fuse type: BKN/75
2	1000 V d.c. (IEC/UL)	250A	100	6500	65	180D5388
		280A	100	9350	70	180D5389
		315A	100	13,000	75	180D5390
		350A	100	16,500	80	180D5391
		400A	100	23,000	85	180D5392
		450A	100	34,000	90	180D5393
		500A	100	48,000	95	180D5394
		550A	100	62,000	100	180D5395

#### Dimensions (mm)

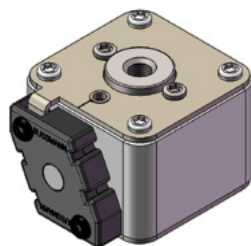
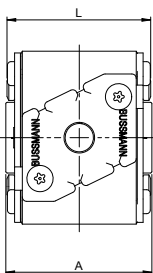
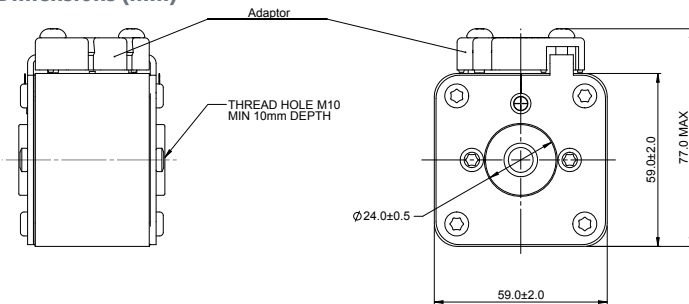

A	L
74.3±1.4	75 ± 1

1000 V d.c. (IEC/UL) - 250 A to 550 A - 180D - Flush end contact fuse body size 2

Time-current curve

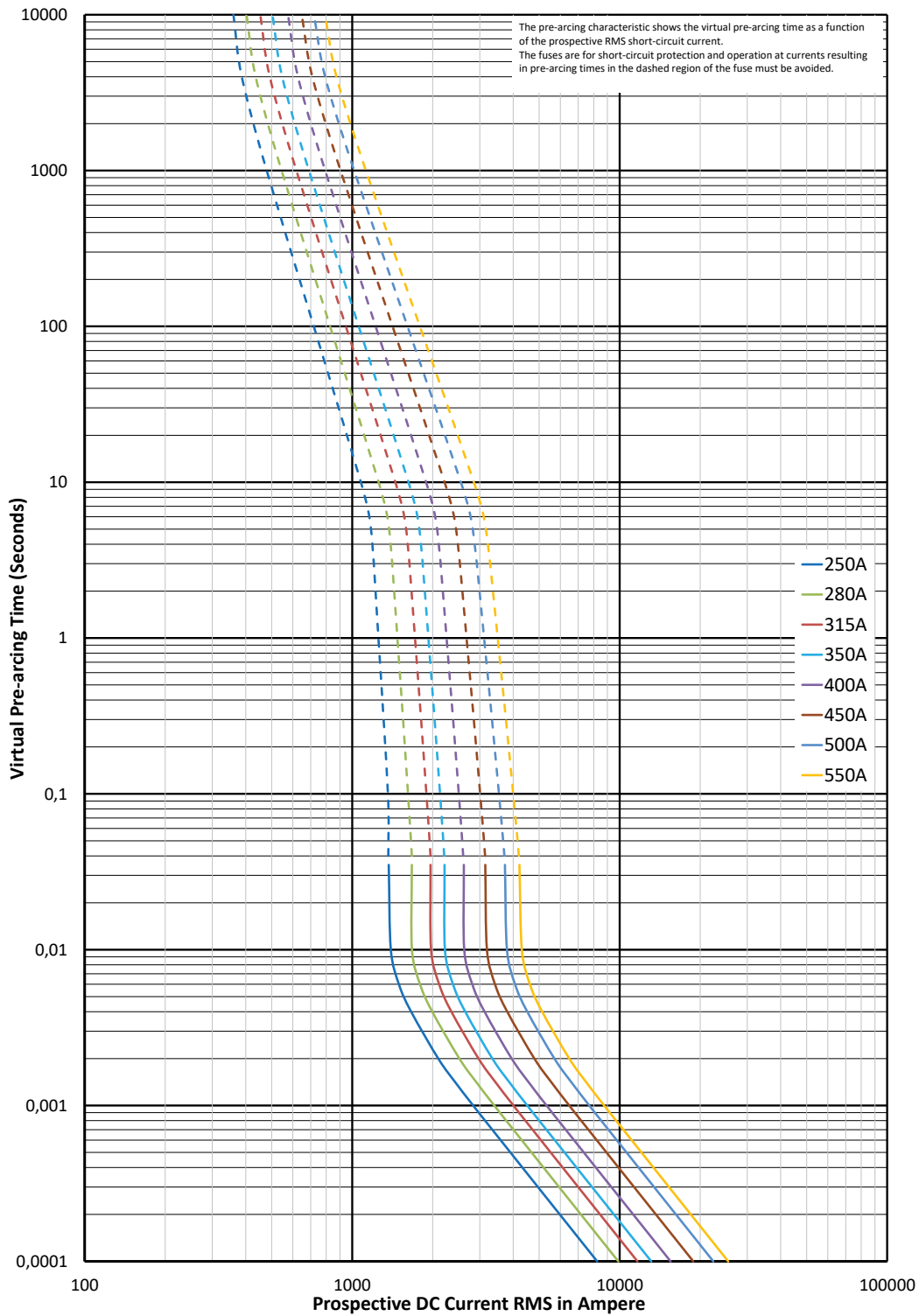

$K_b = 1$     $N = 1,6$

# Square body fuse links

## 1000 V d.c. (IEC/UL) - 250 A to 550 A - 180D - Flush end contact fuse body size 2

### Peak let-through curve

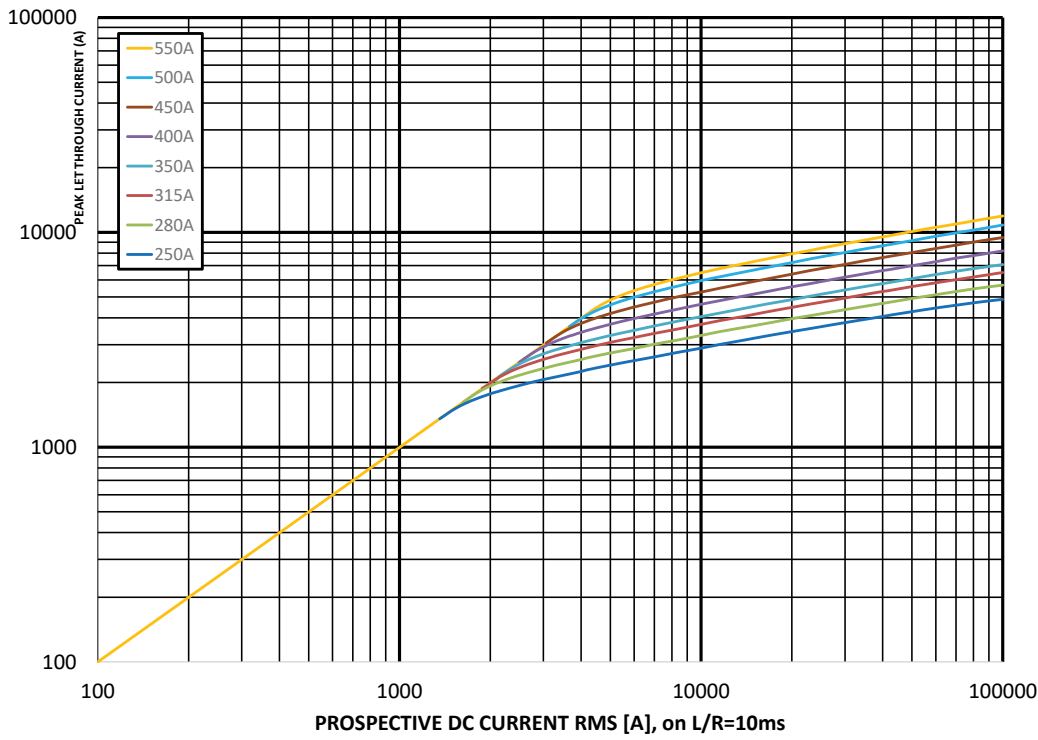

### Watts losses

Watts loss at rated current is given in the electrical characteristics. The curve allows the calculation of the watts losses at load currents lower than the rated current. The correction factor,  $K_p$ , is given as a function of the RMS load current,  $I_b$ , in percent of the rated current.

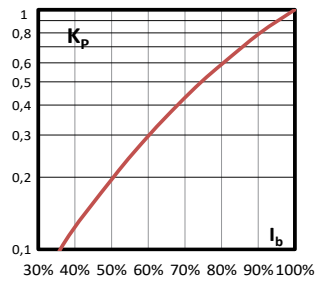

## 1000 V d.c. (UL) - 700 A to 1000 A - 180D - Flush end contact fuse body size 2

### Specifications

#### Description

Eaton's Bussmann series 1000 V d.c. aR square body fuse links deliver fast, dependable protection for advanced DC systems, including DC common bus, EV charging infrastructure, DC drives, and power conversion applications.

#### Technical data

- Rated voltage:
  - 1000 V d.c. (UL) for 700 A and 800 A
  - 900 V d.c. (UL) for 1000 A
- Rated current: 700 A to 1000 A
- Breaking capacity: 70 kA
- Operating class: aR



#### Standards / Agency information

Designed and tested to UL 248-13 Recognised, RoHS compliant

#### Catalog numbers

Fuse body size	Rated voltage	Rated current (Amps)	Breaking capacity (kA)	Minimum pre-arcing $I^2t$ (A <sup>2</sup> Sec)	Power loss at $I_n$ (W)	Catalog number
2	1000 V d.c. (UL)	700	70	160,000	125	180D5447
		800	70	245,000	130	180D5448
	900 V d.c. (UL)	1000	70	480,000	145	180D5500

#### Dimensions (mm)

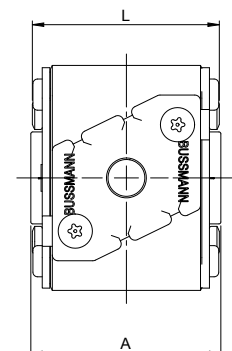
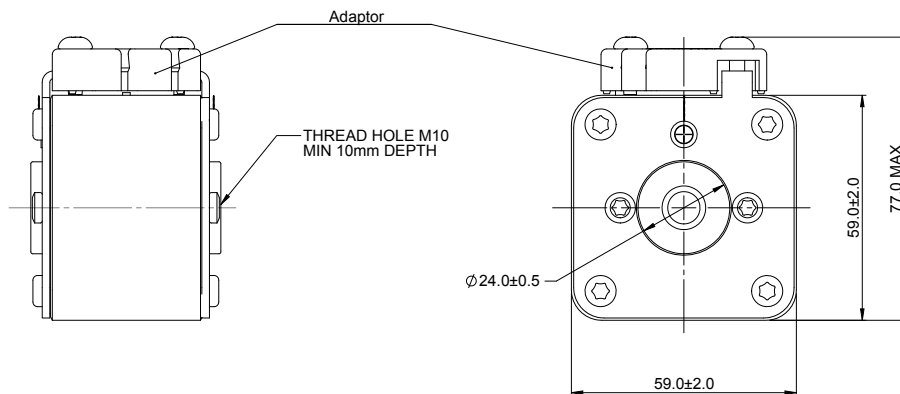

	A	L
700 A and 800 A	80.3 ± 1.5	79.5 ± 1.3
1000 A	91.3 ± 1.5	79.5 ± 1.3

# Square body fuse links

## 1000 V d.c. (UL) - 700 A to 1000 A - 180D - Flush end contact fuse body size 2

Time-current curve

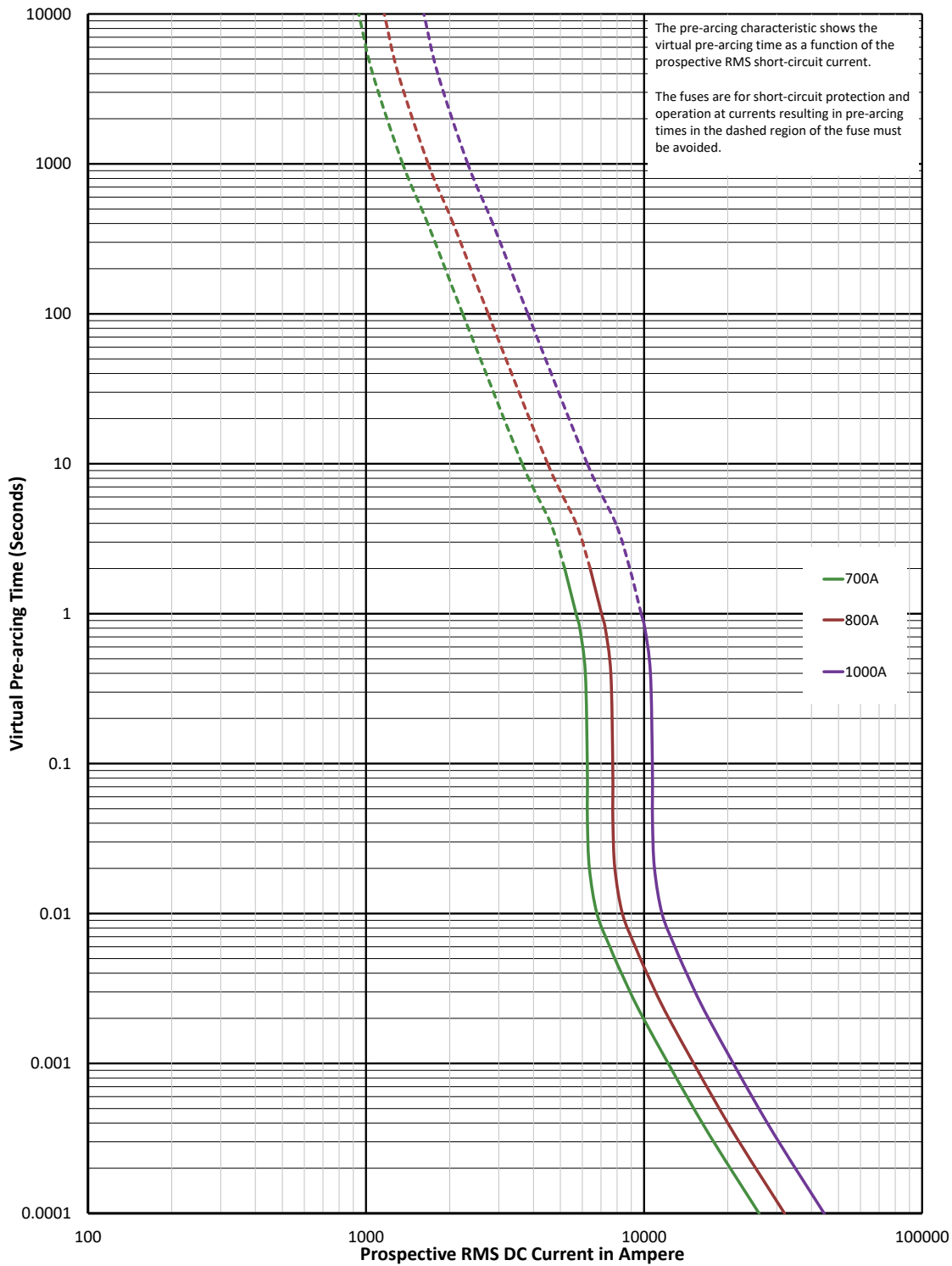

$K_b = 1$     $N = 1.6$

1000 V d.c. (UL) - 700 A to 1000 A - 180D - Flush end contact fuse body size 2

Peak let-through curve



Watts losses

Watts loss at rated current is given in the electrical characteristics. The curve allows the calculation of the watts losses at load currents lower than the rated current. The correction factor,  $K_p$ , is given as a function of the RMS load current,  $I_b$ , in percent of the rated current.

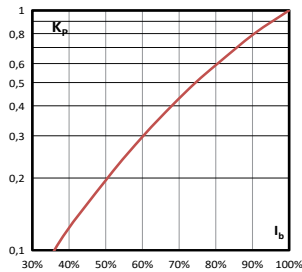

# Square body fuse links

## 1000 V d.c. (IEC), 1125 V d.c. (UL) - 50 A to 125 A - 180D - Square body bladed size 01HT

### Specifications

#### Description

Eaton's Bussmann series 1000 V d.c./1125 V d.c. gR square body fuse links deliver fast, dependable protection for advanced DC systems, including DC common bus, EV charging infrastructure, DC drives, and power conversion applications.

#### Technical data

- Rated voltage: 1000 V d.c. (IEC) 1125 V d.c. (UL)
- Rated current: 50 A to 125 A
- Breaking capacity: 100 kA
- Operating class: gR

#### Compatible fuse holder

- SB1XL-S

#### Standards / Agency information

Designed and tested to IEC 60269 part 4, UL 248-13 Recognised, RoHS compliant

#### Catalog numbers

Fuse body size	Rated voltage	Rated current (Amps)	Breaking capacity (kA at 10ms)	Pre-arcing I <sup>2</sup> t (A <sup>2</sup> Sec)	Power loss at I <sub>n</sub> (W)	Catalog number
01HT	1000 V d.c. (IEC)	50	100	175	25	180D1608
	1125 V d.c. (UL)	63	100	362	26	180D1609
		80	100	565	35	180D1610
		100	100	1100	40	180D1611
		125	100	2200	44	180D1612



#### Dimensions (mm)

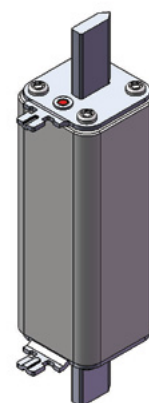
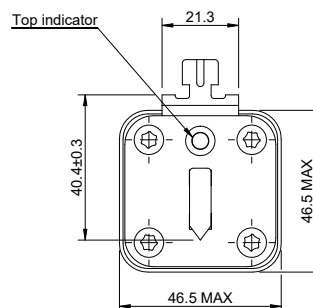
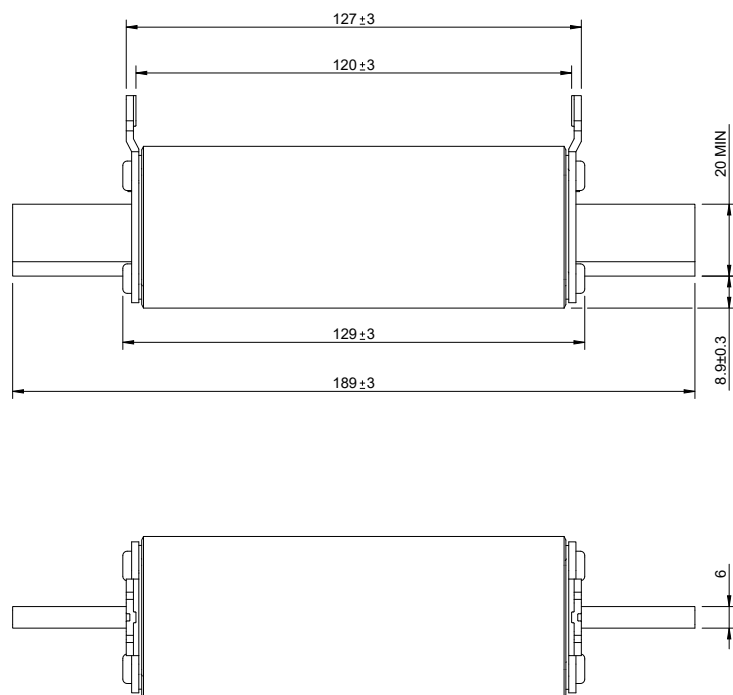

Data sheet: [TD135016EN](#)

1000 V d.c. (IEC), 1125 V d.c. (UL) - 50 A to 125 A - 180D - Square body bladed size 01HT

Time-current curve

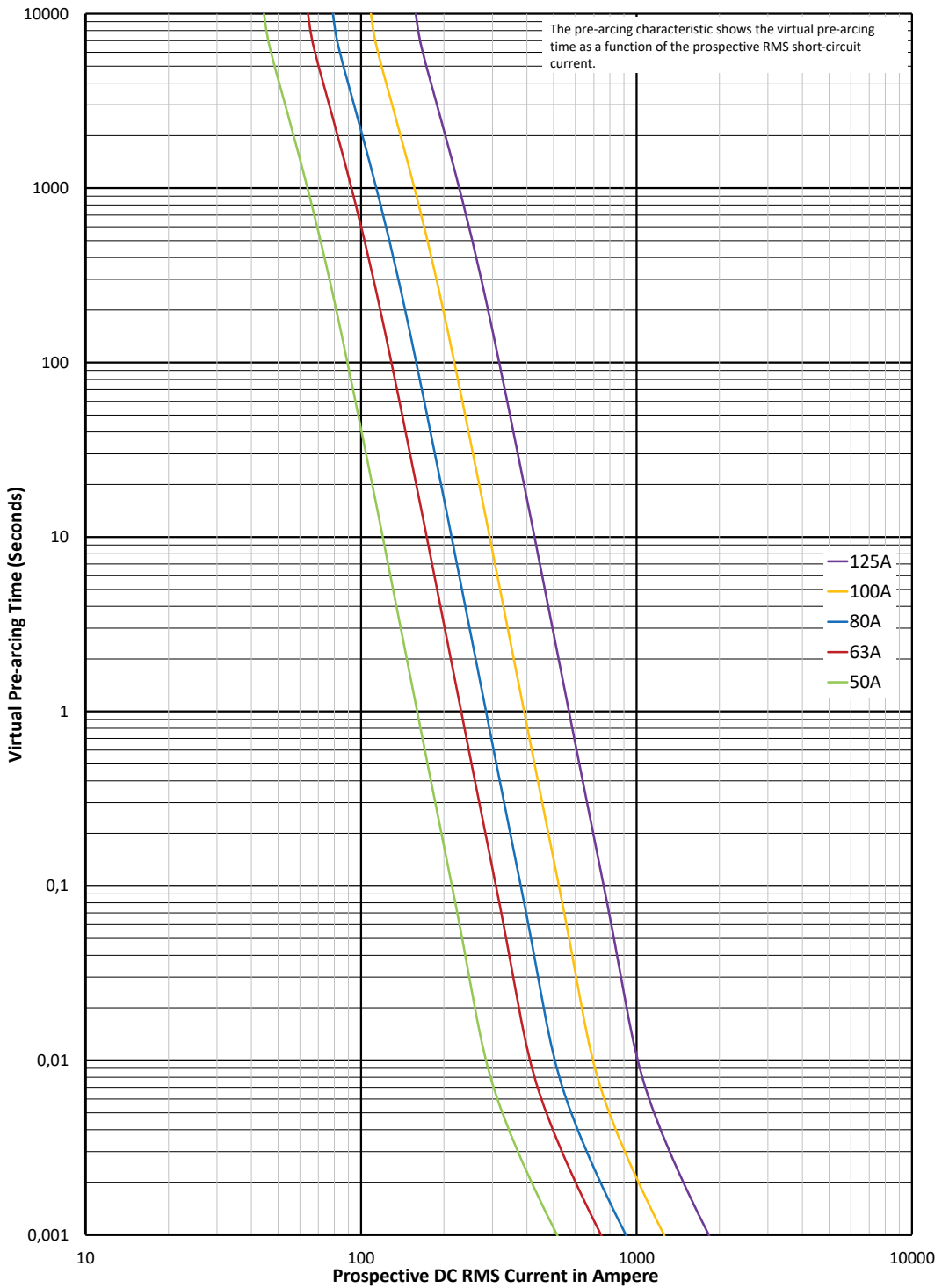

$K_b = \frac{1}{N} = \frac{1}{1,6}$

# Square body fuse links

1000 V d.c. (IEC), 1125 V d.c. (UL) - 50 A to 125 A - 180D - Square body bladed size 01HT

## Peak let-through curve

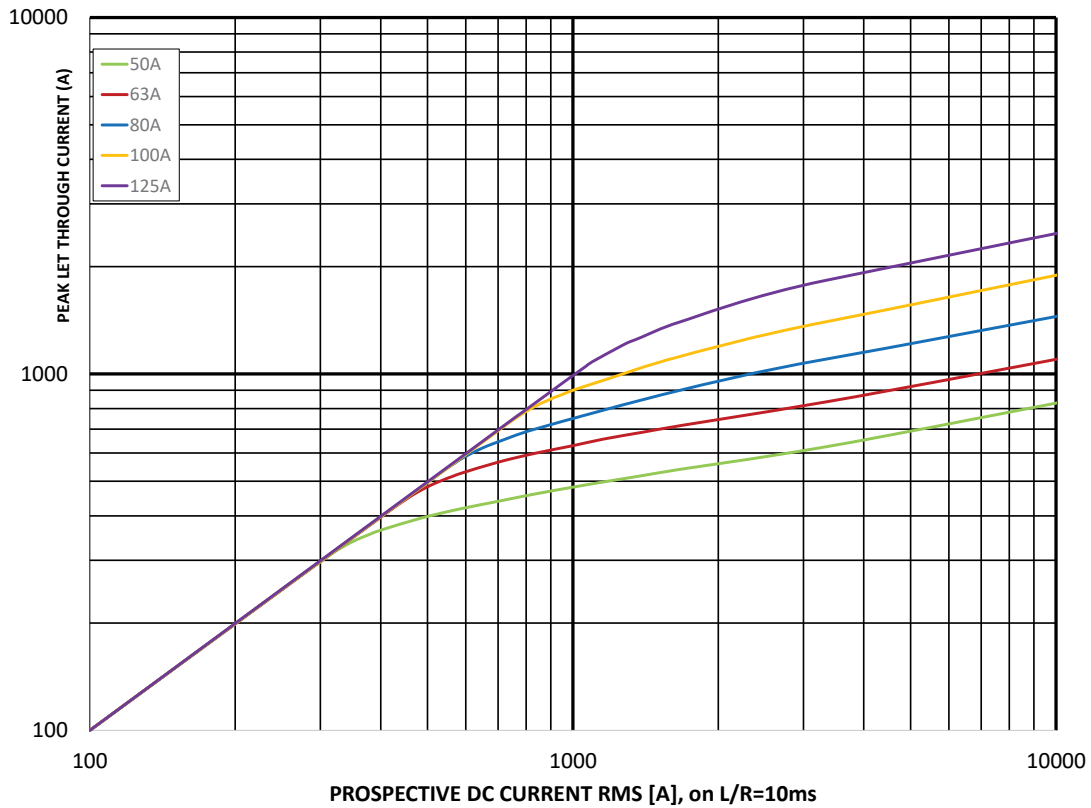

## Watts losses

Watts loss at rated current is given in the electrical characteristics. The curve allows the calculation of the watts losses at load currents lower than the rated current. The correction factor,  $K_p$ , is given as a function of the RMS load current,  $I_b$ , in percent of the rated current.

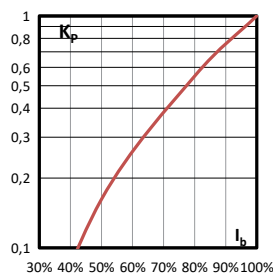

## 1000 V d.c. (IEC), 1125 V d.c. (UL) - 125 A to 250 A - 180D - Square body bladed size 2HT

### Specifications

#### Description

Eaton's Bussmann series 1000 V d.c./1125 V d.c. gR square body fuse links deliver fast, dependable protection for advanced DC systems, including DC common bus, EV charging infrastructure, DC drives, and power conversion applications.

#### Technical data

- Rated voltage: 1000 V d.c. (IEC) 1125 V d.c. (UL)
- Rated current: 125 A to 250 A
- Breaking capacity: 100 kA
- Operating class: gR

#### Compatible fuse holder

- SB2XL-S

#### Standards / Agency information

Designed and tested to IEC 60269 part 4, UL 248-13 Recognised, RoHS compliant

#### Catalog numbers

Fuse body size	Rated voltage	Rated current (Amps)	Breaking capacity (kA at 10ms)	Pre-arcing I <sup>2</sup> t (A <sup>2</sup> Sec)	Power loss at I <sub>n</sub> (W)	Catalog number
2HT	1000 V d.c. (IEC)	125	100	2200	44	180D2612
	1125 V d.c. (UL)	160	100	5000	48	180D2613
		200	100	8800	57	180D2614
		250	100	16,600	70	180D2615



#### Dimensions (mm)

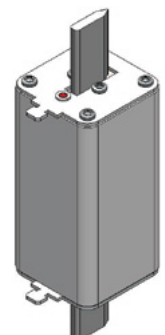
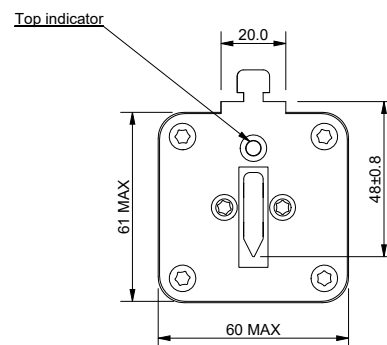
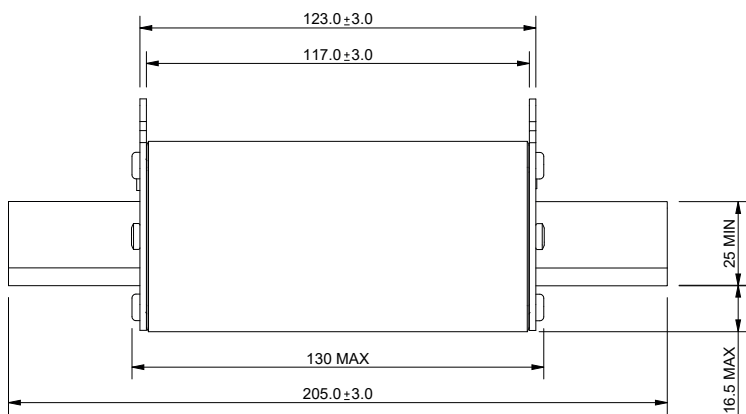

Data sheet: [TD135017EN](#)

# Square body fuse links

## 1000 V d.c. (IEC), 1125 V d.c. (UL) - 125 A to 250 A - 180D - Square body bladed size 2HT

Time-current curve

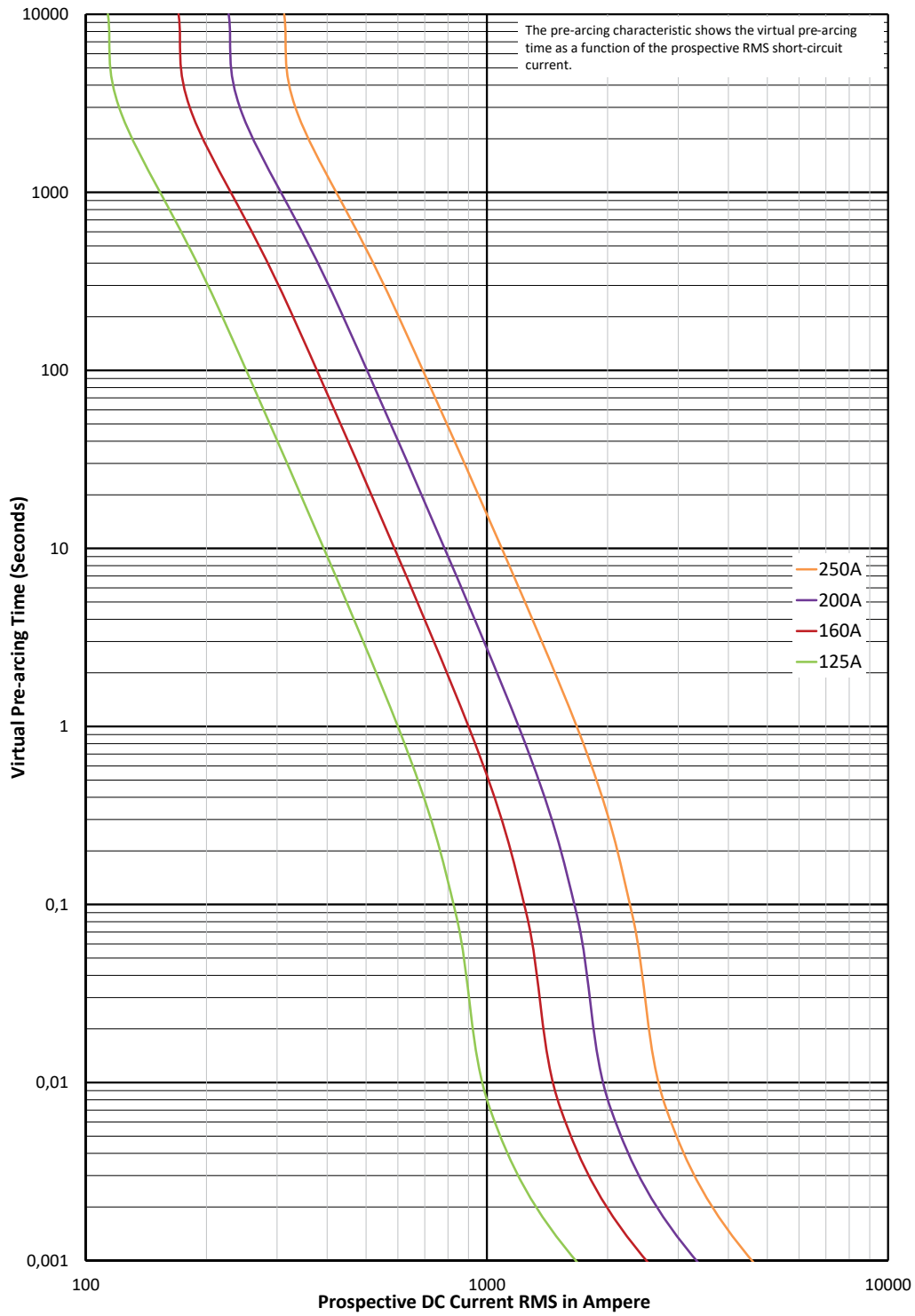

$K_b = 1$   $N = 1,6$

1000 V d.c. (IEC), 1125 V d.c. (UL) - 125 A to 250 A - 180D - Square body bladed size 2HT

Peak let-through curve

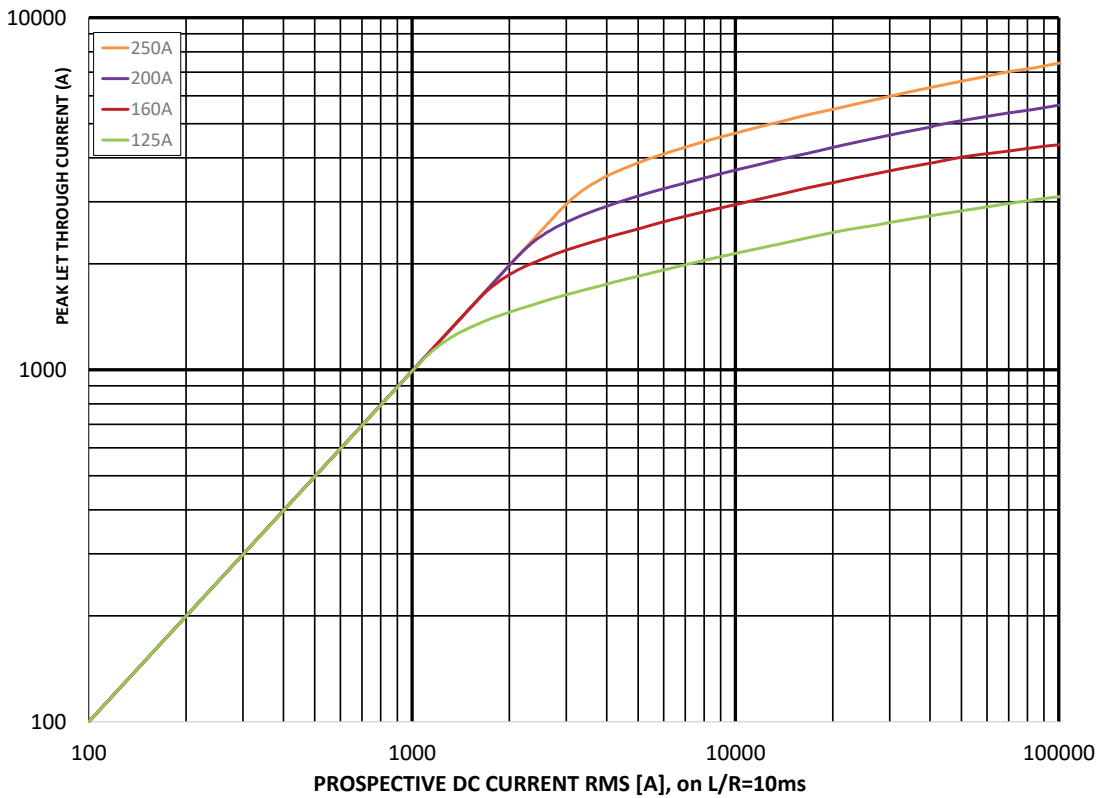

Watts losses

Watts loss at rated current is given in the electrical characteristics. The curve allows the calculation of the watts losses at load currents lower than the rated current. The correction factor,  $K_p$ , is given as a function of the RMS load current,  $I_b$ , in percent of the rated current.

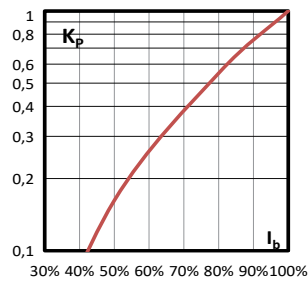

# Square body fuse links

## 1000 V d.c. (IEC), 1125 V d.c. (UL) - 250 A to 500 A - 180D Square body bladed size 3HT

### Specifications

#### Description

Eaton's Bussmann series 1000 V d.c./1125 V d.c. gR square body fuse links deliver fast, dependable protection for advanced DC systems, including DC common bus, EV charging infrastructure, DC drives, and power conversion applications.

#### Technical data

- Rated voltage: 1000 V d.c. (IEC) 1125 V d.c. (UL)
- Rated current: 250 A to 500 A
- Breaking capacity: 100 kA
- Operating class: gR

#### Compatible fuse holder

- SB3L-S

#### Compatible microswitch

- 170H0236

#### Standards / Agency information

Designed and tested to IEC 60269 part 4, UL 248-13 Recognised, RoHS compliant

#### Catalog numbers

Fuse body size	Rated voltage	Rated current Amps	Breaking capacity (kA at 10ms)	Pre-arcing I <sup>2</sup> t (A <sup>2</sup> Sec)	Power loss at In (W)	Catalog number
3HT	1000 V d.c. (IEC)	250	100	74,000	49	180D3615
	1125 V d.c. (UL)	315	100	150,000	52	180D3616
		355	100	195,000	59	180D3617
		400	100	296,000	61	180D3618
		450	100	412,000	67	180D3619
		500	100	532,000	73	180D3620



#### Dimensions (mm)

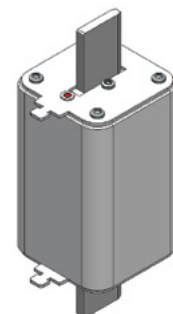
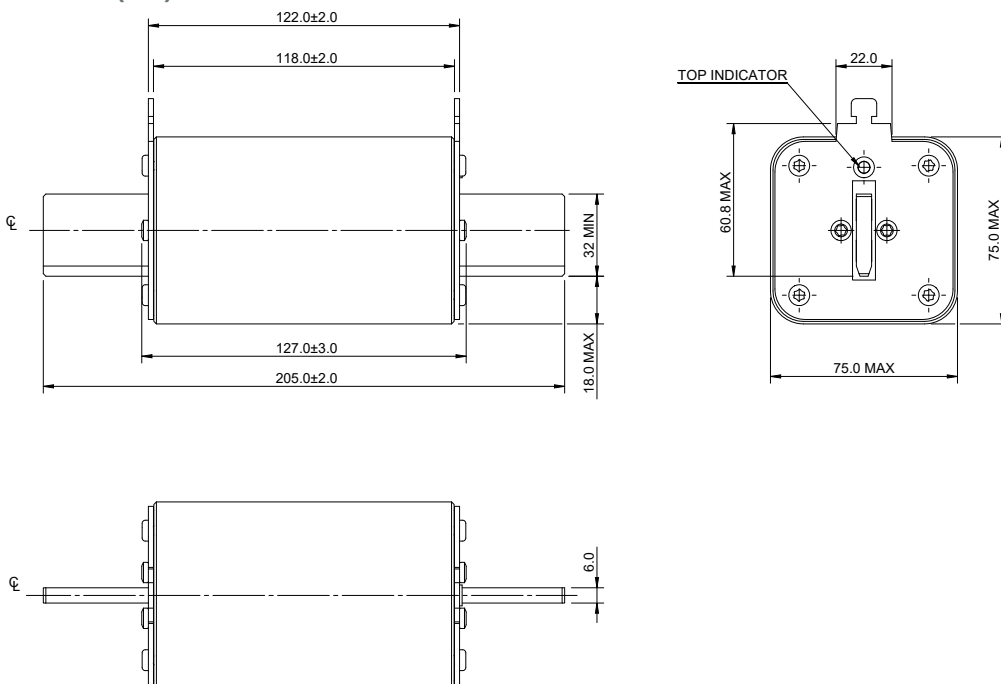

Data sheet: [TD135018EN](#)

1000 V d.c. (IEC), 1125 V d.c. (UL) - 250 A to 500 A - 180D Square body bladed size 3HT

Time-current curve

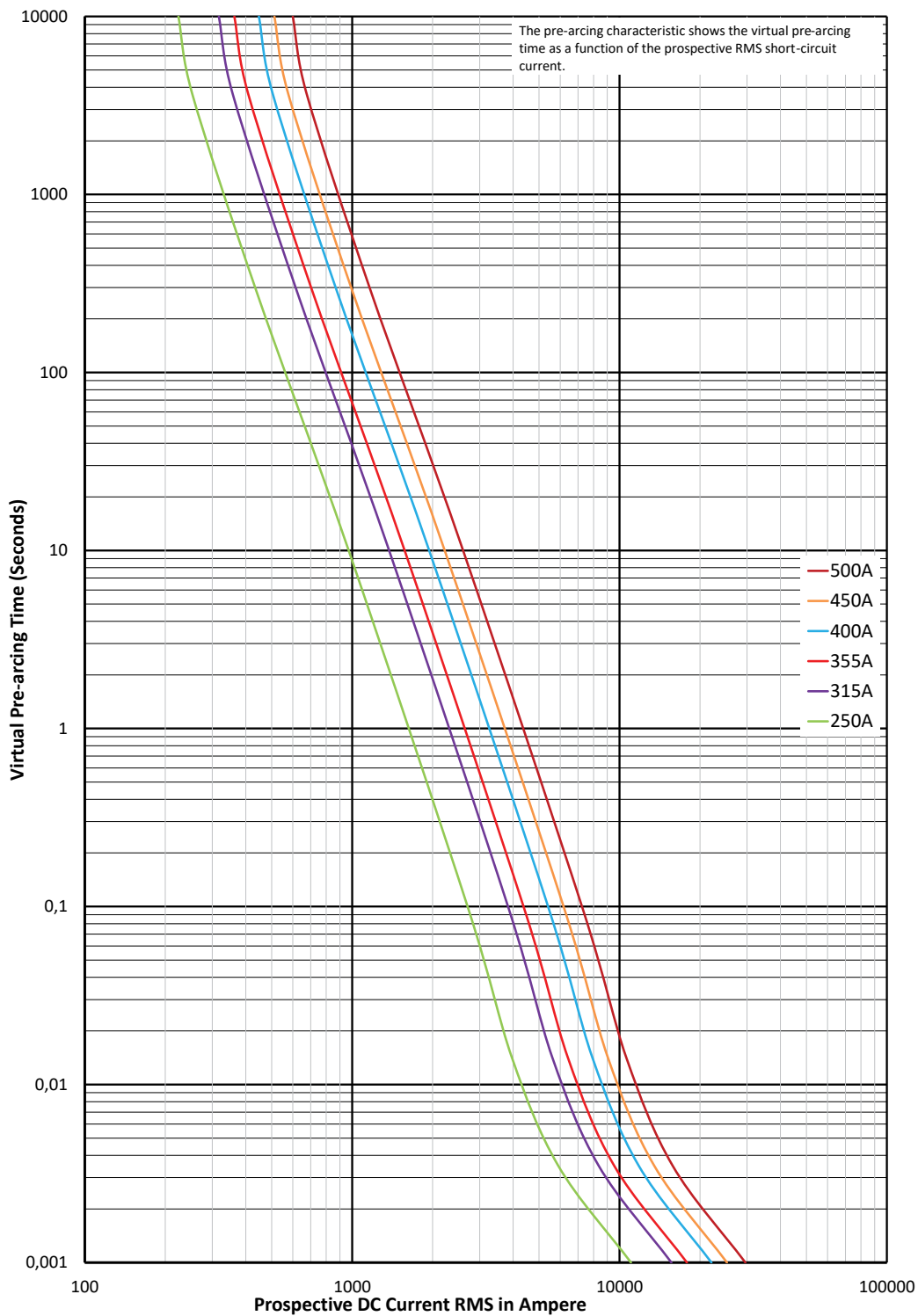

$K_b = 1$   $N = 1,6$

# Square body fuse links

1000 V d.c. (IEC), 1125 V d.c. (UL) - 250 A to 500 A - 180D Square body bladed size 3HT

## Peak let-through curve

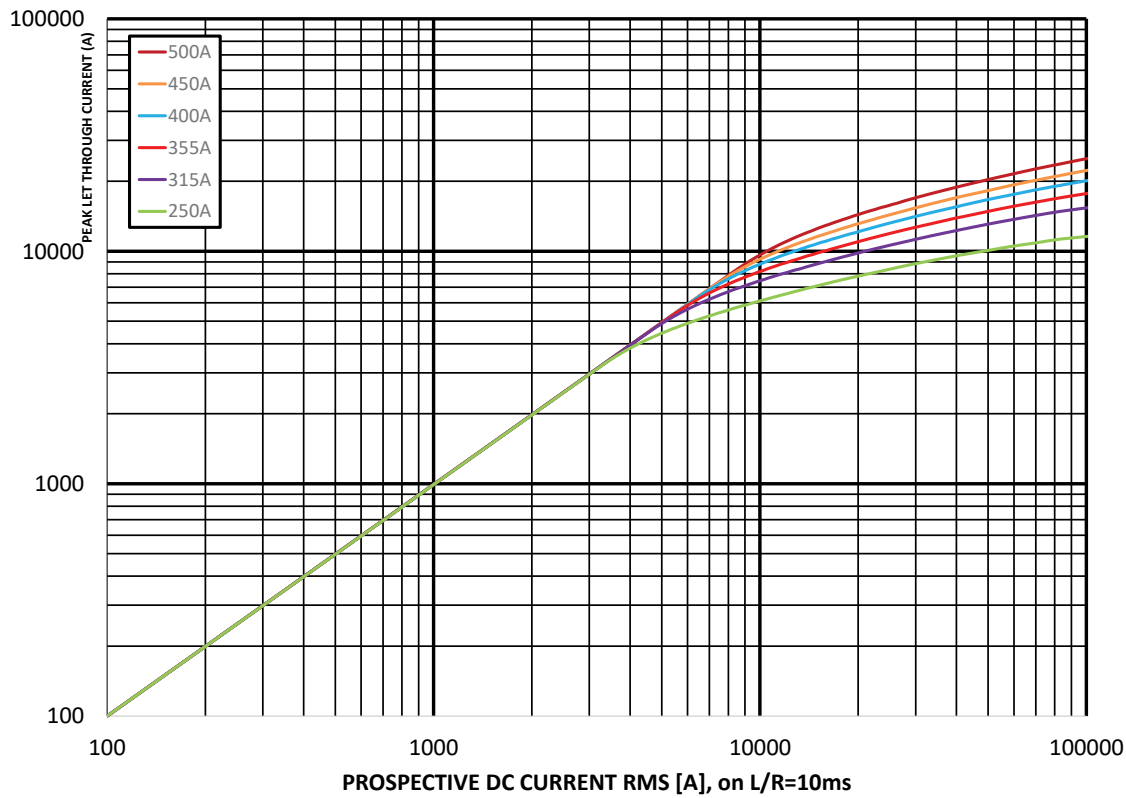

## Watts losses

Watts loss at rated current is given in the electrical characteristics. The curve allows the calculation of the watts losses at load currents lower than the rated current. The correction factor,  $K_p$ , is given as a function of the RMS load current,  $I_b$ , in percent of the rated current.

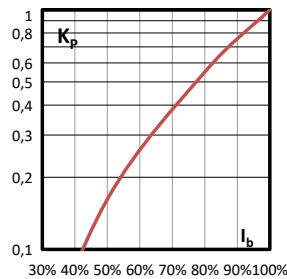

1500 V d.c. (IEC/UL) - 100 A to 315 A - 180D - Flush end, DIN and US Style contact fuse size 1

Specifications

Description

Eaton's Bussmann series 1500 V d.c. aR and aBAT square body fuse links provide fast, reliable protection for modern DC systems including BESS, EV charging infrastructure, DC drives, and power conversion applications.

Technical data

- Rated voltage: 1500 V d.c. (IEC/UL)
- Rated current: 100 A to 315 A
- Breaking capacity:
  - 100 kA at 10 ms L/R
  - 250 kA at 3ms L/R
- Operating class: aR and aBat

Compatible microswitch

- 170H0069



Standards / Agency information

Designed and tested to IEC 60269 part 4 and 7, UL 248-13  
Recognised, RoHS compliant

Catalog numbers

Fuse body size	Rated voltage	Rated current (Amps)	Minimum breaking capacity (A)	Maximum breaking capacity	Pre-arcing I <sup>2</sup> t (A <sup>2</sup> Sec)	Power loss at In (W)	Catalog number		
							Fuse type: 1BKN/130 (Flush end)	Fuse type: 1KE/160 (DIN)	Fuse type: 1FKE/170 (US Style)
1	1500 V d.c. (IEC/UL)	100	205	100kA at 10ms L/R	815	56	180D7420	180D7426	180D7432
		125	300	250kA at 3ms L/R	1700	65	180D7421	180D7427	180D7433
		160	435		3800	70	180D7422	180D7428	180D7434
		200	605		7300	80	180D7423	180D7429	180D7435
		250	875		15,000	90	180D7424	180D7430	180D7436
		315	1245		31,000	100	180D7425	180D7431	180D7437

Dimensions (mm) - 1BKN/130 (Flush end)

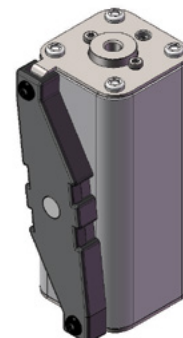
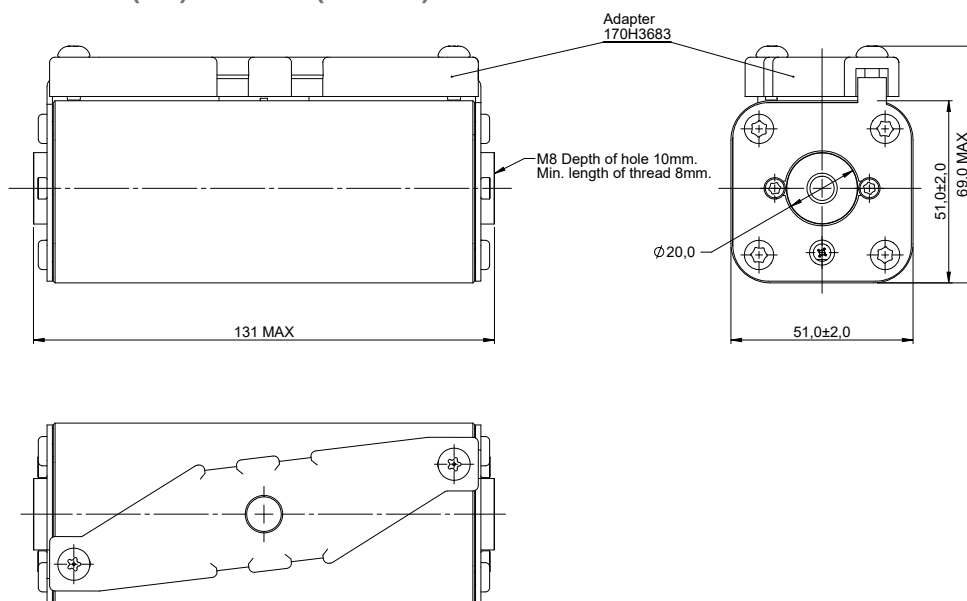

Data sheet: [TD135025EN](#)

# Square body fuse links

## 1500 V d.c. (IEC/UL) - 100 A to 315 A - 180D - Flush end, DIN and US Style contact fuse size 1

### Dimensions (mm) - 1KE/160 (DIN)

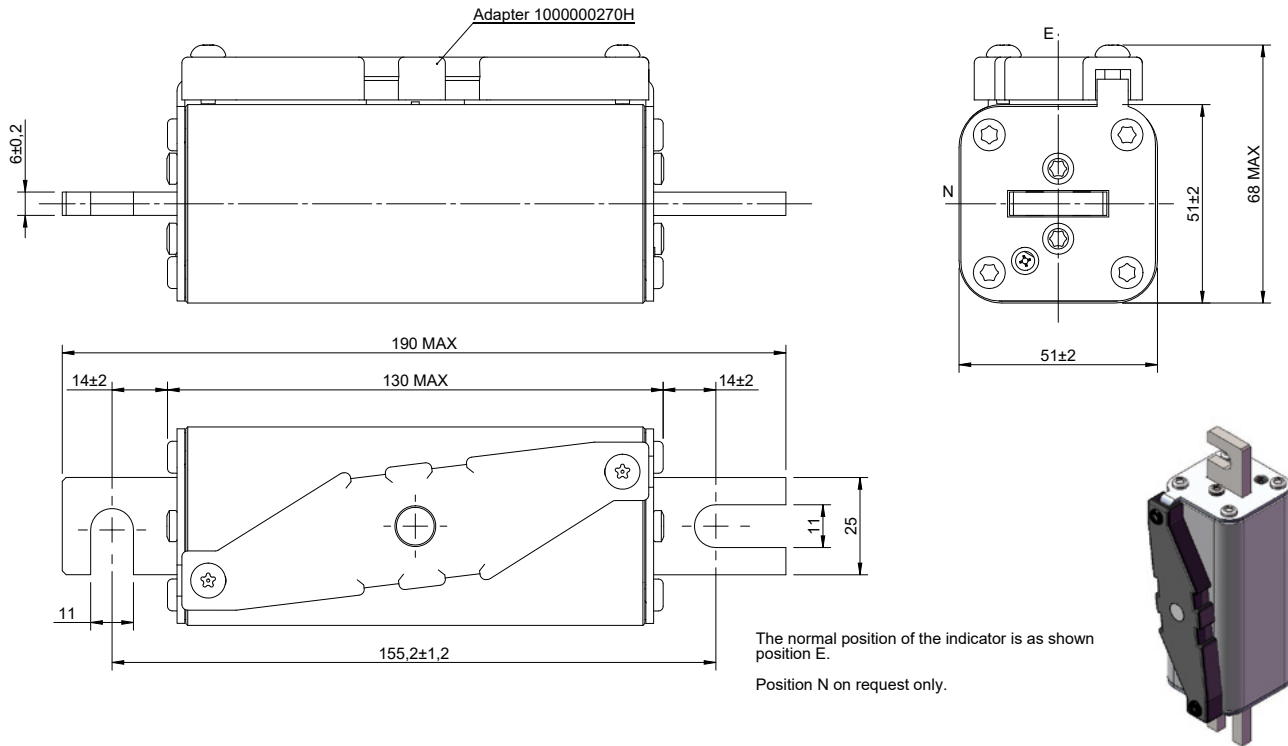

### Dimensions (mm)- 1FKE/170 (US Style)

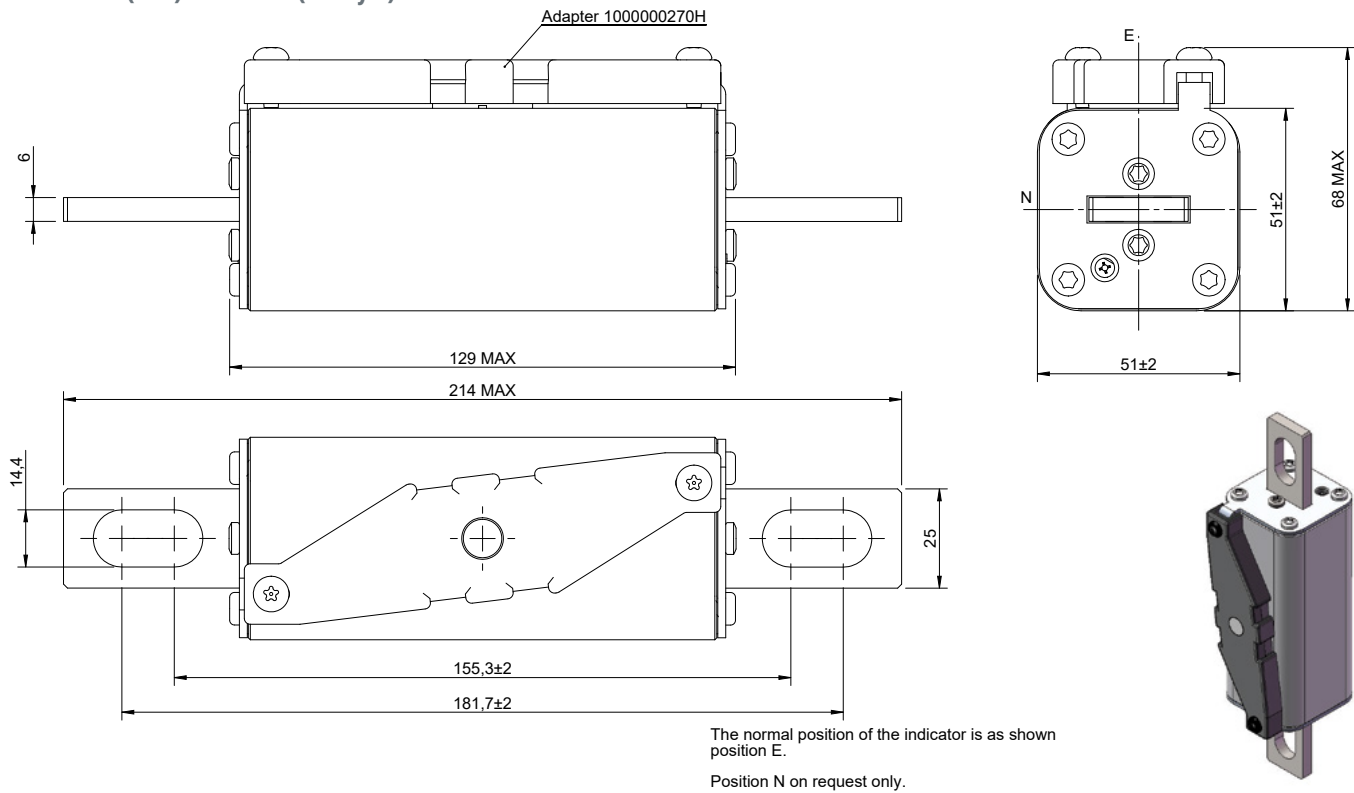

1500 V d.c. (IEC/UL) - 100 A to 315 A - 180D - Flush end, DIN and US Style contact fuse size 1

Time-current curve

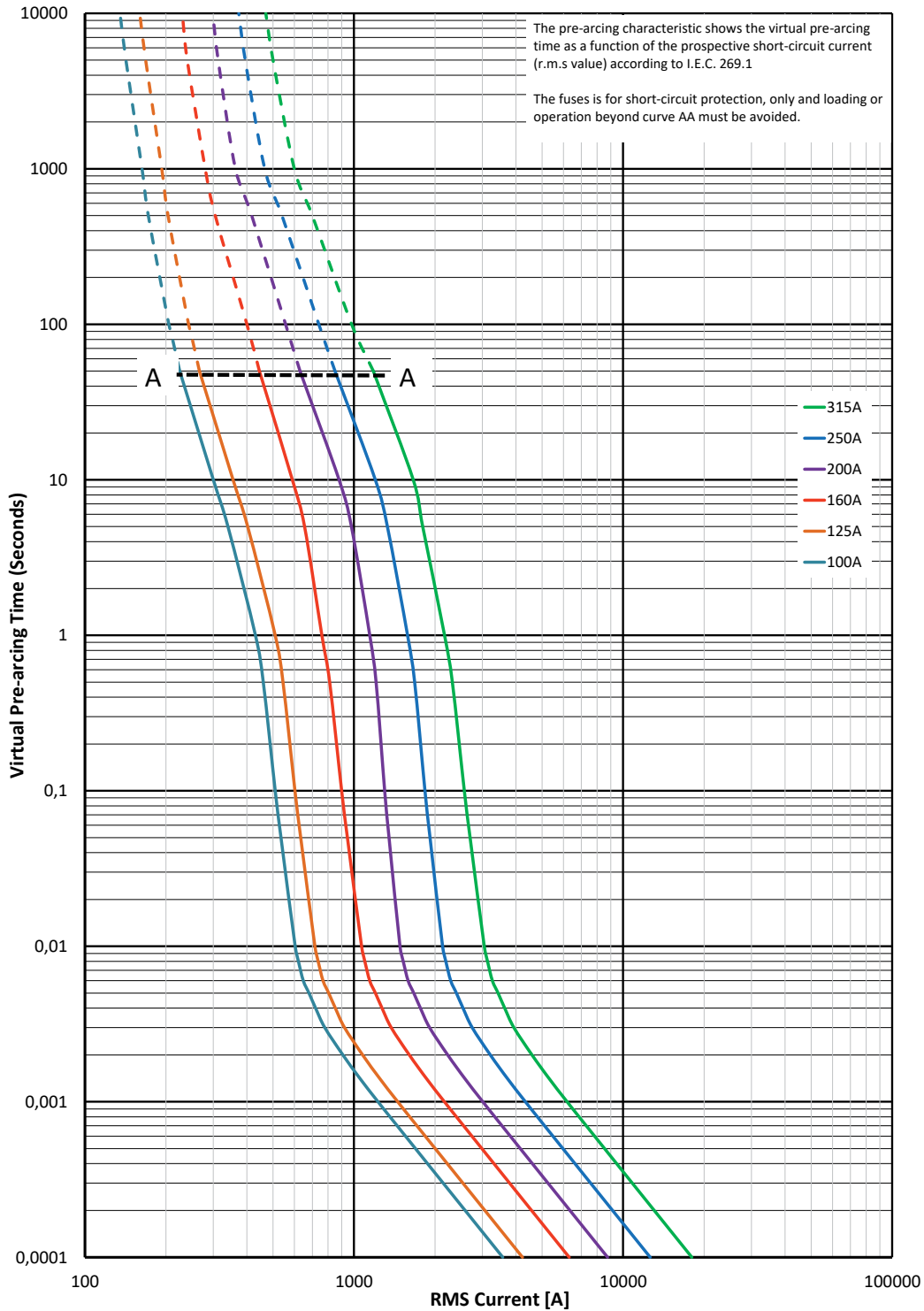

$K_b = 1$

# Square body fuse links

## 1500 V d.c. (IEC/UL) - 100 A to 315 A - 180D - Flush end, DIN and US Style contact fuse size 1

### Peak let-through curve

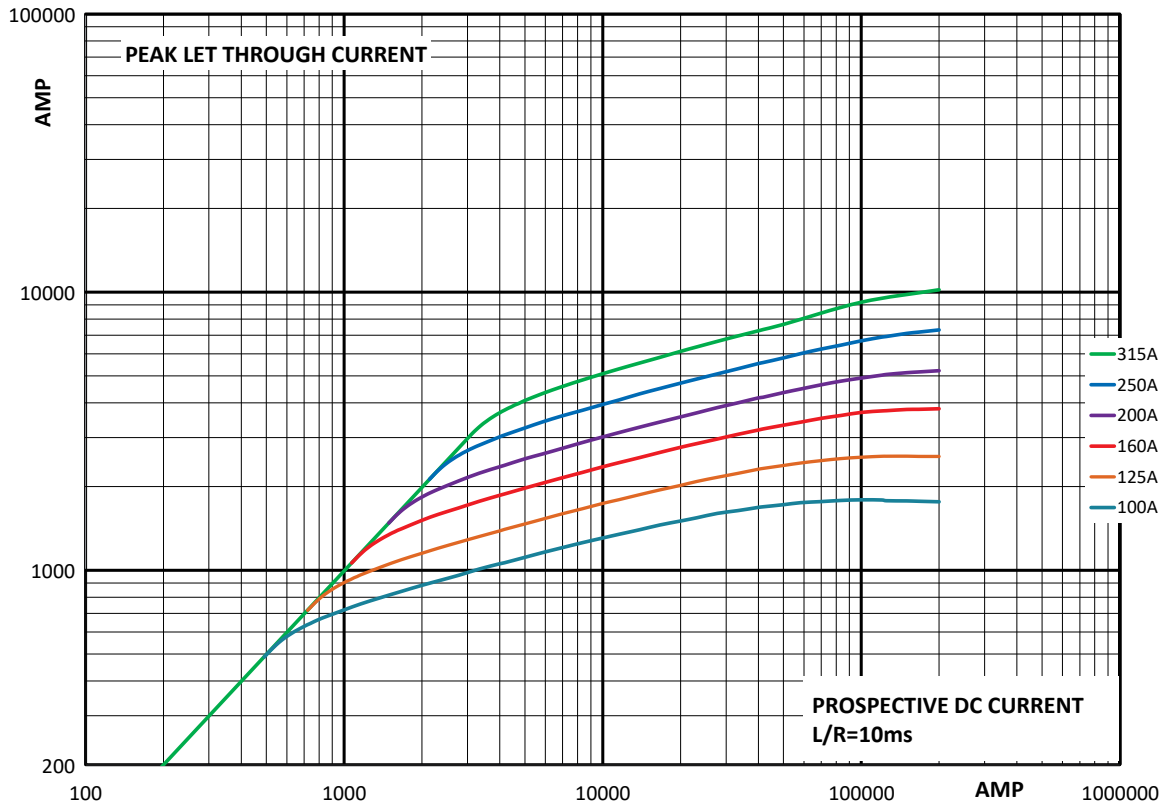

### Watts losses

Watts loss at rated current is given in the electrical characteristics. The curve allows the calculation of the watts losses at load currents lower than the rated current. The correction factor,  $K_p$ , is given as a function of the RMS load current,  $I_b$ , in percent of the rated current.

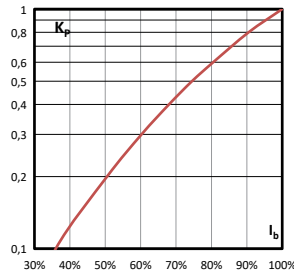

1500 V d.c. (IEC/UL) - 100 A to 450 A - ESS2 and ESS2-NI - Size 2

Specifications

Description

Eaton's Bussmann series 1500 V d.c. aR square body fuse links provide fast, reliable protection for modern DC systems including BESS, EV charging infrastructure, DC drives, and power conversion applications.

Technical data

- Rated voltage: 1500 V d.c. (IEC/UL)
- Rated current: 100 A to 450 A
- Breaking capacity:
  - 150 kA at 10ms L/R
  - 250 kA at 4ms L/R
- Operating class: aR and aBat



Standards / Agency information

Designed and tested to IEC 60269 part 4 and 7, UL 248-13  
Recognised, RoHS compliant

Catalog numbers - ESS

Fuse body size	Rated voltage	Rated current (Amps)	Breaking capacity	Minimum breaking current	Pre-arcing I <sup>2</sup> t (A <sup>2</sup> Sec)	Power loss at In (W)	Catalog number				
							Fuse type: 2L (Dual slotted)	Fuse type: 2H (US Style)	Fuse type: 2B (Flush end)	Fuse type: 2J (DIN 43653)	Fuse type: 2J-L (DIN 43653)
2	1500 V d.c. (IEC/UL)	100	150 kA at 10ms L/R	500	1000	50	ESS2L-100	ESS2H-100	ESS2B-100	ESS2J-100	ESS2J-100L
		125		625	3000	60	ESS2L-125	ESS2H-125	ESS2B-125	ESS2J-125	ESS2J-125L
		160	250 kA at 4ms L/R	800	5300	74	ESS2L-160	ESS2H-160	ESS2B-160	ESS2J-160	ESS2J-160L
		200		1000	10,000	87	ESS2L-200	ESS2H-200	ESS2B-200	ESS2J-200	ESS2J-200L
		250		1250	19,000	94	ESS2L-250	ESS2H-250	ESS2B-250	ESS2J-250	ESS2J-250L
		315	1575	38,000	113	ESS2L-315	ESS2H-315	ESS2B-315	ESS2J-315	ESS2J-315L	
		350	1750	53,000	117	ESS2L-350	ESS2H-350	ESS2B-350	ESS2J-350	ESS2J-350L	
		400	2000	79,000	129	ESS2L-400	ESS2H-400	ESS2B-400	ESS2J-400	ESS2J-400L	
		450	2250	111,000	139	ESS2L-450	ESS2H-450	ESS2B-450	ESS2J-450	ESS2J-450L	

Catalog numbers - ESS-NI

Fuse body size	Rated voltage	Rated current (Amps)	Breaking capacity	Minimum breaking current	Pre-arcing I <sup>2</sup> t (A <sup>2</sup> Sec)	Power loss at In (W)	Catalog number				
							Fuse type: 2L (Dual slotted)	Fuse type: 2H (US Style)	Fuse type: 2B (Flush end)	Fuse type: 2J (DIN 43653)	Fuse type: 2J-L (DIN 43653)
2	1500 V d.c. (IEC/UL)	100	150 kA at 10ms L/R	500	1000	50	ESS2L-100-NI	ESS2H-100-NI	ESS2B-100-NI	ESS2J-100-NI	ESS2J-100L-NI
		125		625	3000	60	ESS2L-125-NI	ESS2H-125-NI	ESS2B-125-NI	ESS2J-125-NI	ESS2J-125L-NI
		160	250 kA at 4ms L/R	800	5300	74	ESS2L-160-NI	ESS2H-160-NI	ESS2B-160-NI	ESS2J-160-NI	ESS2J-160L-NI
		200		1000	10,000	87	ESS2L-200-NI	ESS2H-200-NI	ESS2B-200-NI	ESS2J-200-NI	ESS2J-200L-NI
		250		1250	19,000	94	ESS2L-250-NI	ESS2H-250-NI	ESS2B-250-NI	ESS2J-250-NI	ESS2J-250L-NI
		315	1575	38,000	113	ESS2L-315-NI	ESS2H-315-NI	ESS2B-315-NI	ESS2J-315-NI	ESS2J-315L-NI	
		350	1750	53,000	117	ESS2L-350-NI	ESS2H-350-NI	ESS2B-350-NI	ESS2J-350-NI	ESS2J-350L-NI	
		400	2000	79,000	129	ESS2L-400-NI	ESS2H-400-NI	ESS2B-400-NI	ESS2J-400-NI	ESS2J-400L-NI	
		450	2250	111,000	139	ESS2L-450-NI	ESS2H-450-NI	ESS2B-450-NI	ESS2J-450-NI	ESS2J-450L-NI	

Data sheet: [TD135030EN](#)

# Square body fuse links

## 1500 V d.c. (IEC/UL) - 100 A to 450 A - ESS2 and ESS2-NI - Size 2

### Dimensions (mm) - ESS 2L (Dual slotted)

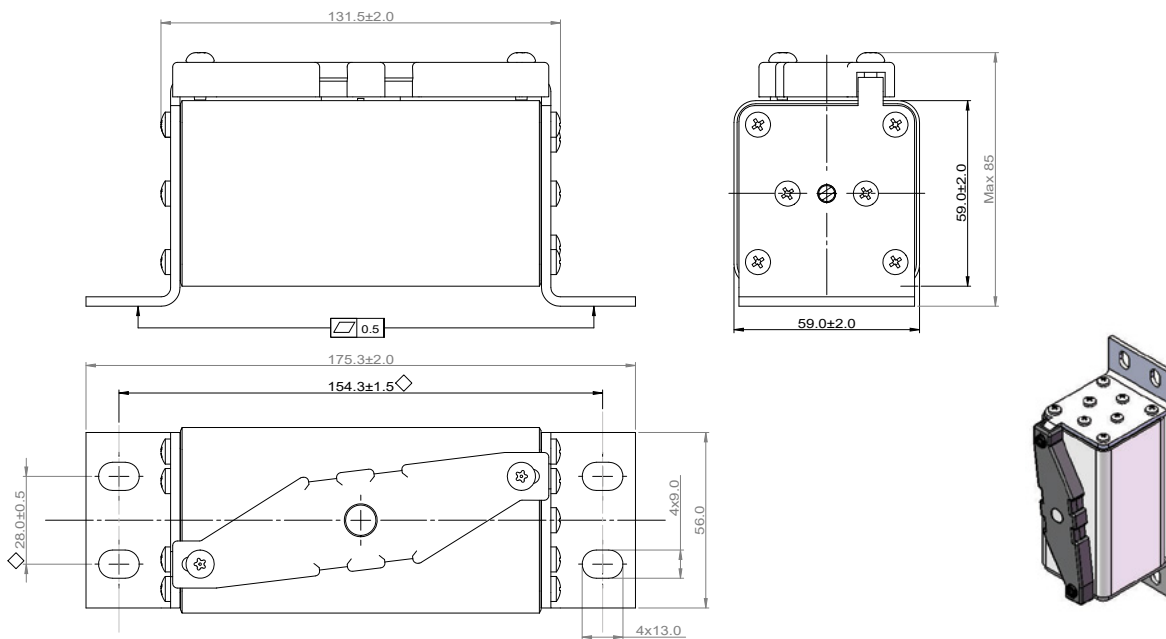

### Dimensions (mm) - ESS 2H (US Style)

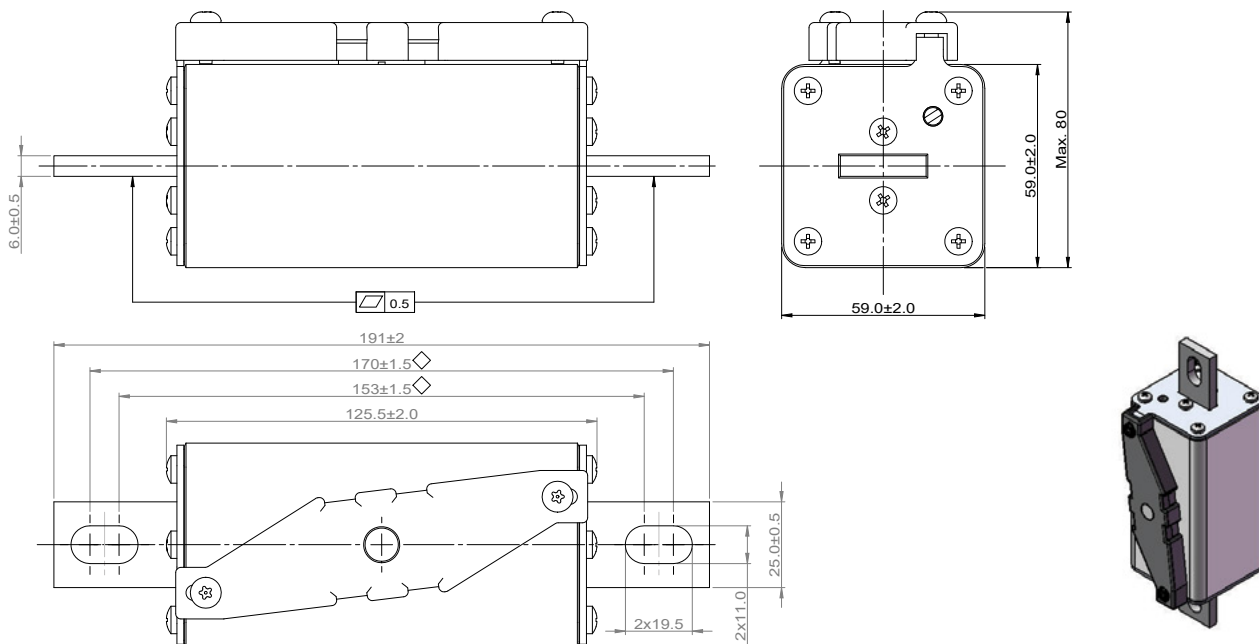

1500 V d.c. (IEC/UL) - 100 A to 450 A - ESS2 and ESS2-NI - Size 2

Dimensions (mm) - ESS 2B (Flush end)

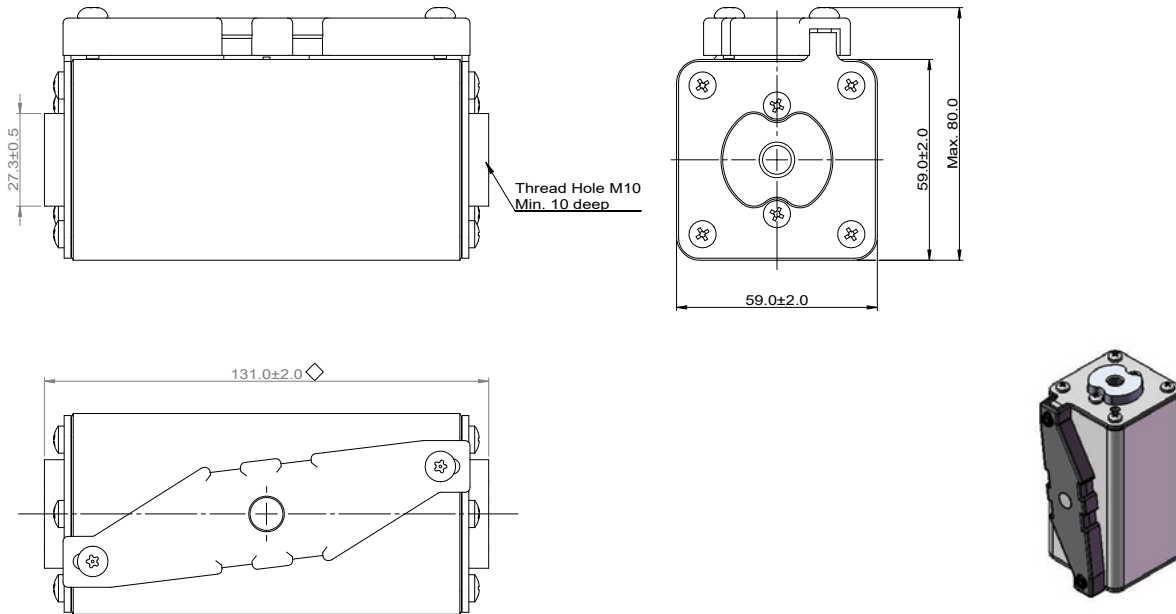

Dimensions (mm) - ESS 2J (DIN 43653)

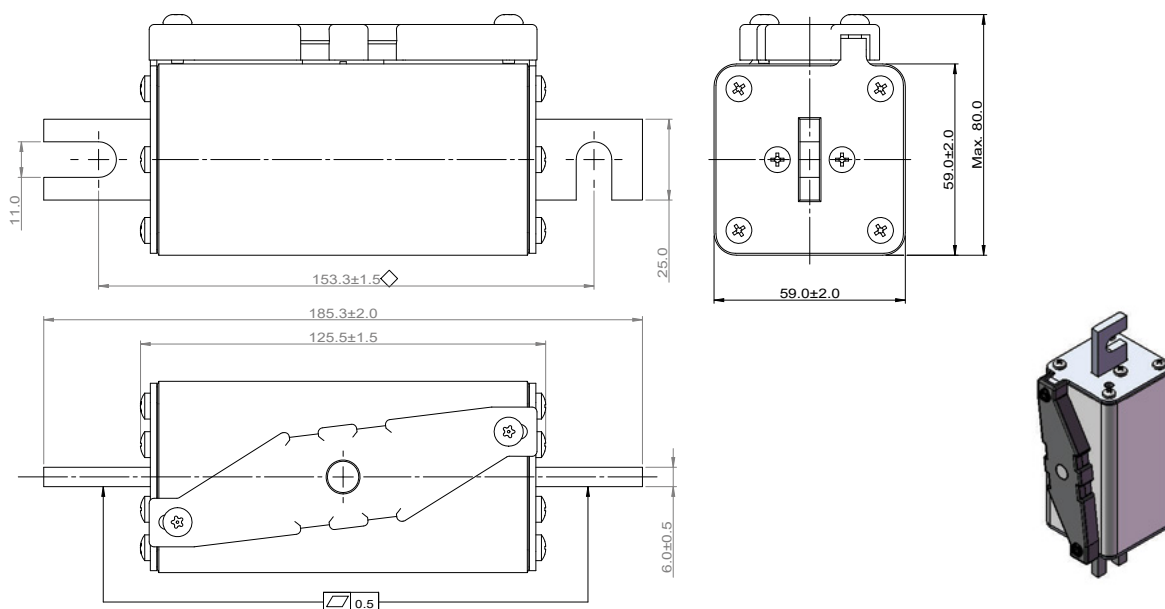

# Square body fuse links

## 1500 V d.c. (IEC/UL) - 100 A to 450 A - ESS2 and ESS2-NI - Size 2

Dimensions (mm) - ESS 2J-L (DIN 43653)

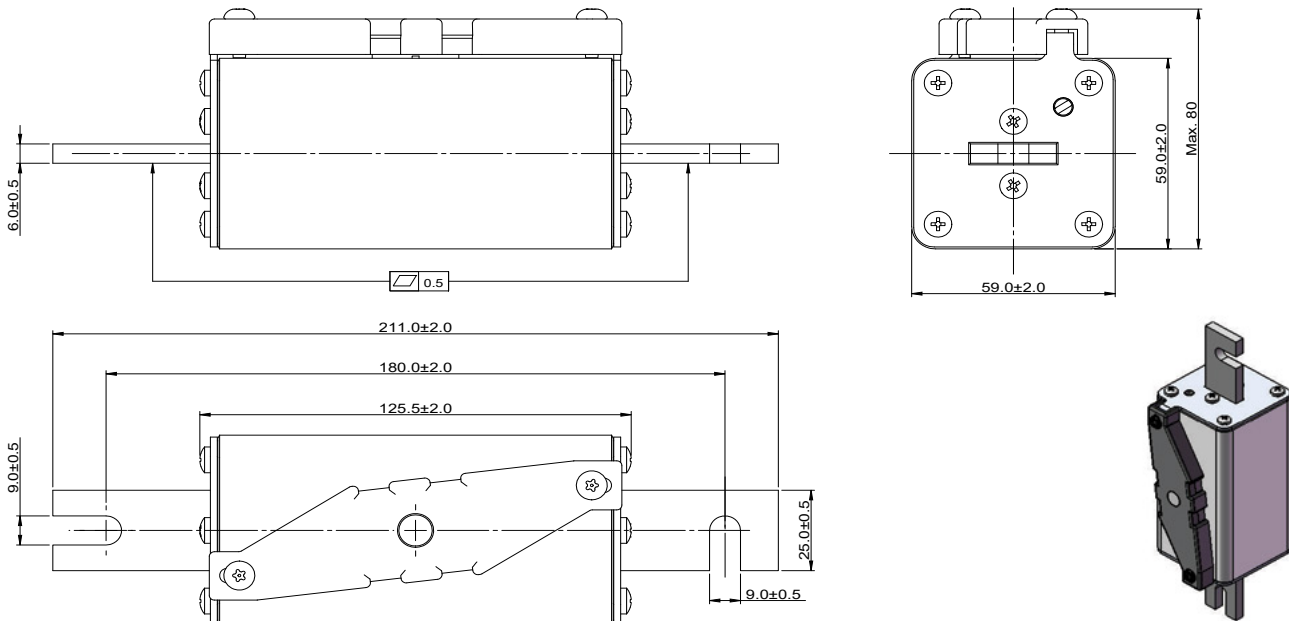

Dimensions (mm) - ESS-NI 2L (Dual slotted)

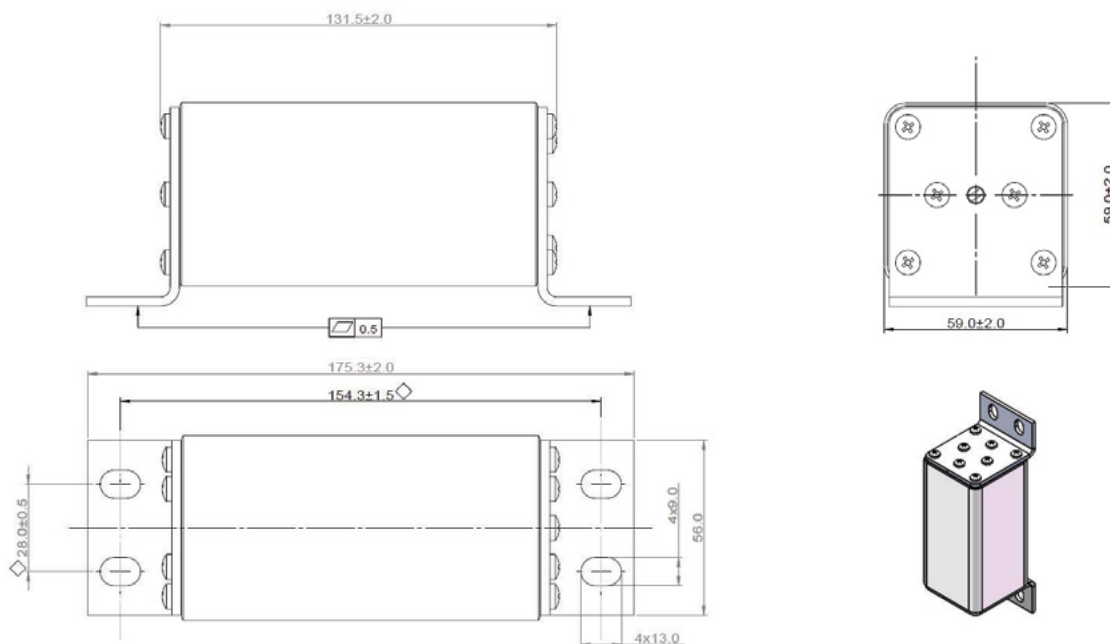

Data sheet: [ID135030EN](#)

1500 V d.c. (IEC/UL) - 100 A to 450 A - ESS2 and ESS2-NI - Size 2

Dimensions (mm) - ESS-NI 2H (US Style)

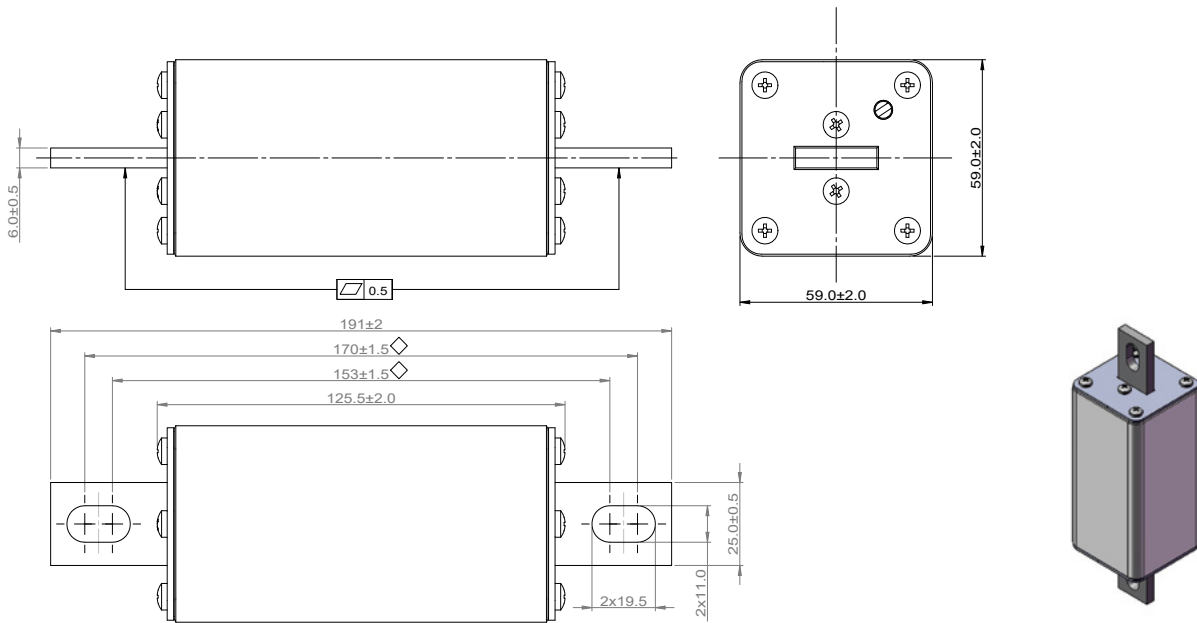

Dimensions (mm) - ESS-NI 2B (Flush end)

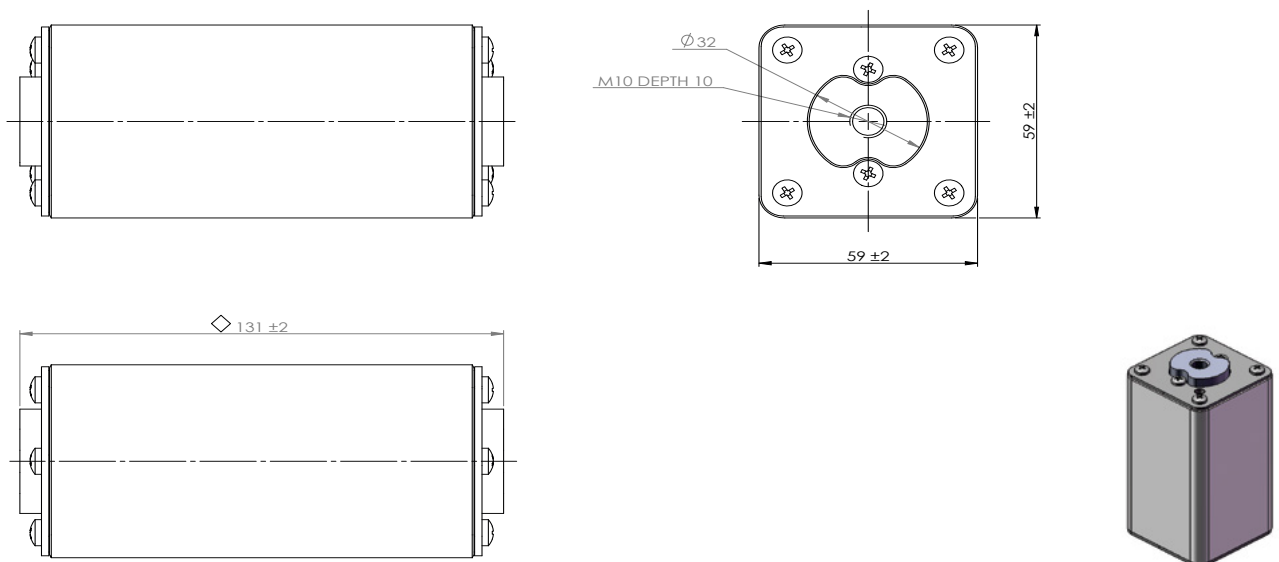

# Square body fuse links

## 1500 V d.c. (IEC/UL) - 100 A to 450 A - ESS2 and ESS2-NI - Size 2

### Dimensions (mm) - ESS-NI 2J (DIN 43653)

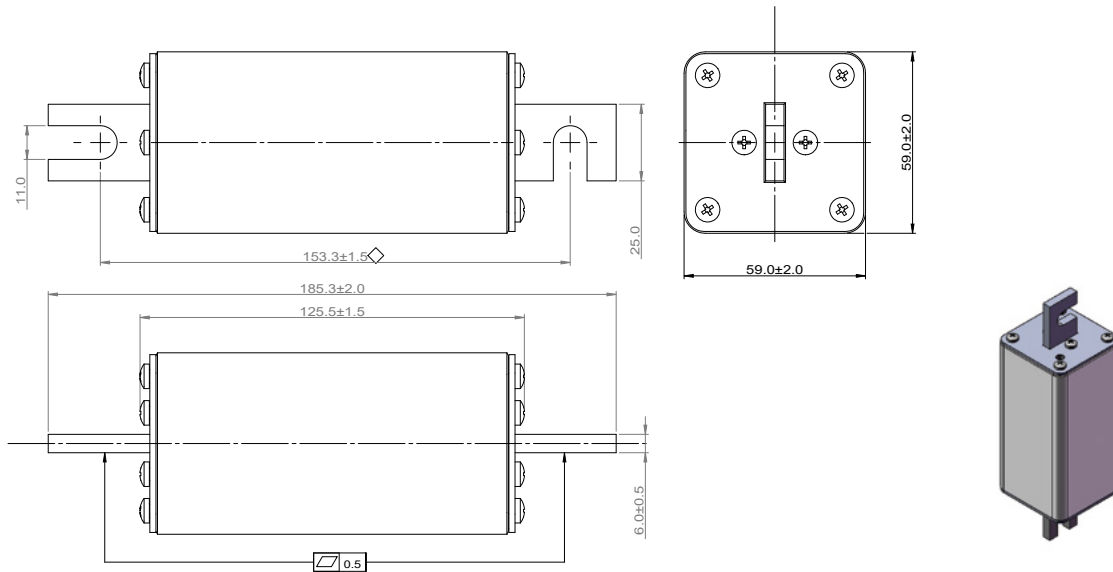

### Dimensions (mm) - ESS-NI 2J-L (DIN 43653)

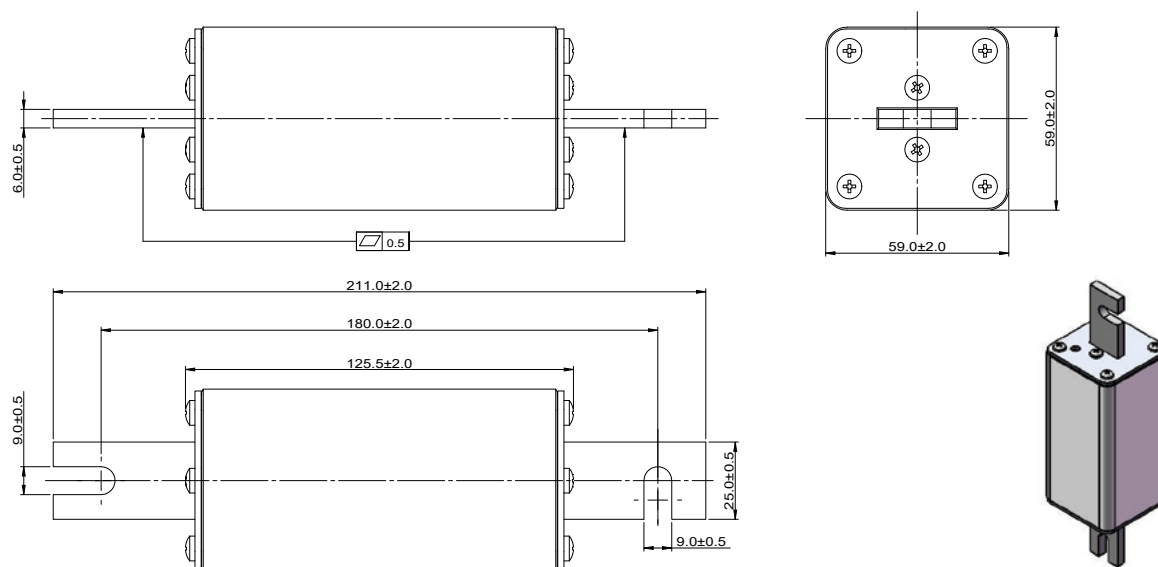

1500 V d.c. (IEC/UL) - 100 A to 450 A - ESS2 and ESS2-NI - Size 2

Time-current curve

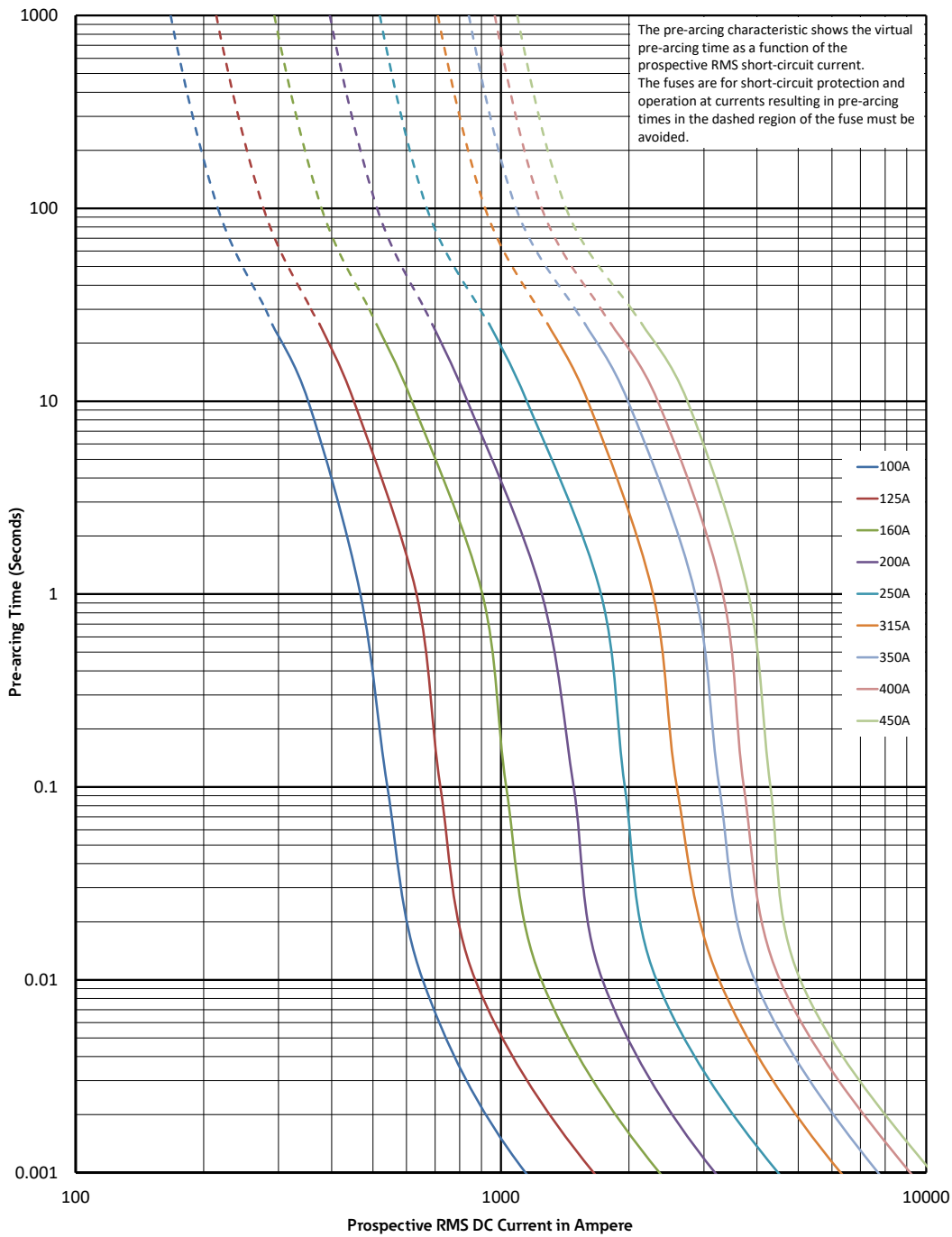

# Square body fuse links

## 1500 V d.c. (IEC/UL) - 100 A to 450 A - ESS2 and ESS2-NI - Size 2

### Peak let-through curve

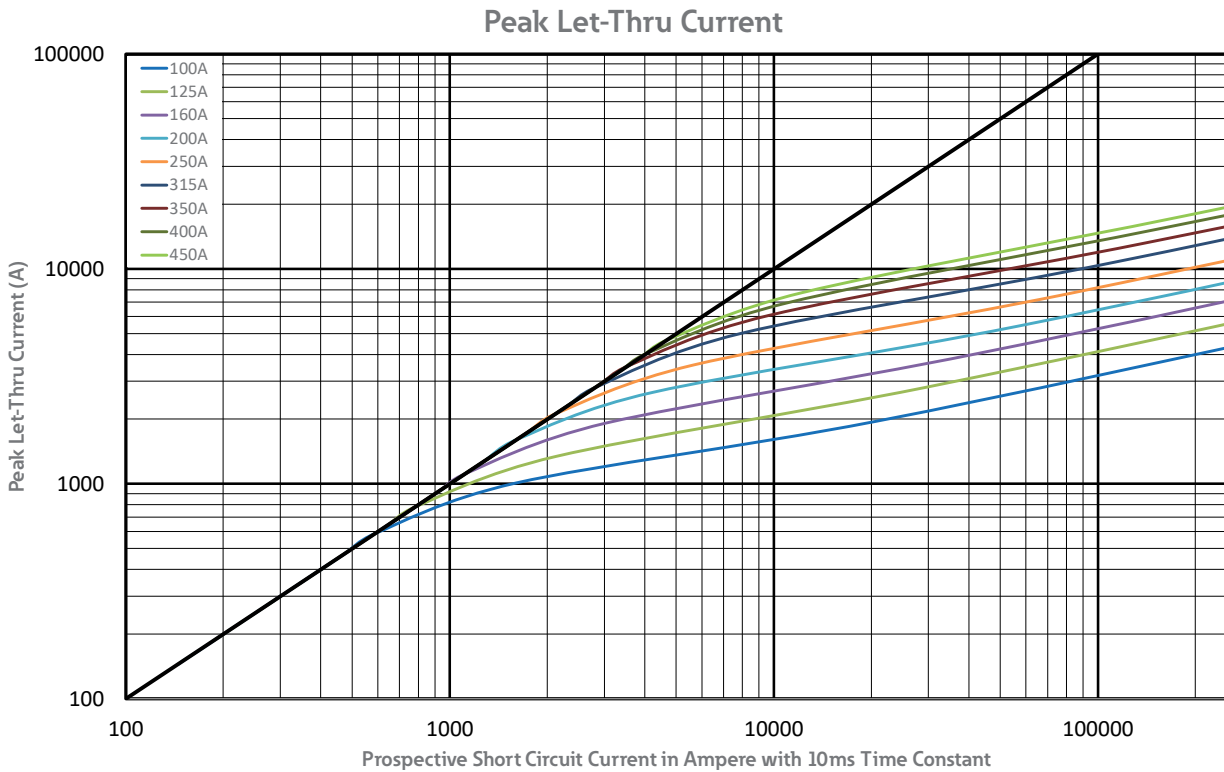

#### Total clearing $I^2t$

The total clearing  $I^2t$  at rated voltage and tested DC time constant are given in electrical characteristics. For other voltages the clearing  $I^2t$  is found by multiplying by correction factor, K, given as a function of applied working voltages, E.

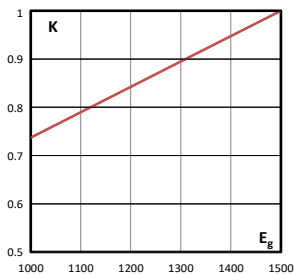

#### Watts losses

Watts loss at rated current is given in the electrical characteristics. The curve allows the calculation of the watts losses at load currents lower than the rated current. The correction factor,  $K_p$ , is given as a function of the RMS load current,  $I_b$ , in percent of the rated current.

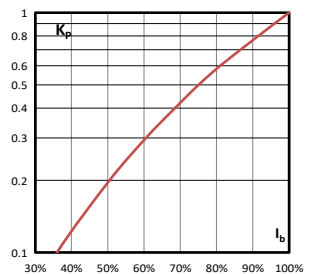

## 1500 V d.c. (IEC/UL) - 125 A to 500 A - 180D - Flush end, DIN and US Style contact fuse size 2

### Specifications

#### Description

Eaton's Bussmann series 1500 V d.c. aR and aBat square body fuse links provide fast, reliable protection for modern DC systems including BESS, EV charging infrastructure, DC drives, and power conversion applications.

#### Technical data

- Rated voltage: 1500 V d.c. (IEC/UL)
- Rated current: 125 A to 500 A
- Breaking capacity:
  - 100 kA at 10 ms L/R
  - 250 kA at 3ms L/R
- Operating class: aR and aBat

#### Compatible microswitch

- Flush end: 170H0069
- DIN and US Style tag: 170H0235

#### Standards / Agency information

Designed and tested to IEC 60269 part 4 and 7, UL 248-13  
Recognised, RoHS compliant



### Catalog numbers

Fuse body size	Rated voltage	Rated current (Amps)	Breaking capacity	Minimum breaking current	Pre-arcing I <sup>2</sup> t (A <sup>2</sup> Sec)	Power loss at In (W)	Catalog number		
							Fuse type: 2BKN/140	Fuse type: 2TN/170	Fuse type: 2FTN/180
2	1500 V d.c. (IEC/UL)	125	100 kA at 10ms L/R	400	1500	71	180D5699	180D5849	180D5949
		160		600	3500	77	180D5700	180D5850	180D5950
		200	250 kA at 3ms L/R	800	6000	90	180D5701	180D5851	180D5951
		250		1250	24,000	56	180D5702	180D5852	180D5952
		315		1750	48,500	63	180D5703	180D5853	180D5953
		350		2050	67,000	70	180D5704	180D5854	180D5954
		400		2450	94,500	79	180D5705	180D5855	180D5955
		450		3200	138,000	83	180D5706	180D5856	180D5956
		500		3430	190,000	88	180D5707	180D5857	180D5957

# Square body fuse links

## 1500 V d.c. (IEC/UL) - 125 A to 500 A - 180D - Flush end, DIN and US Style contact fuse size 2

### Dimensions (mm) - 2BKN/140 (Flush end)

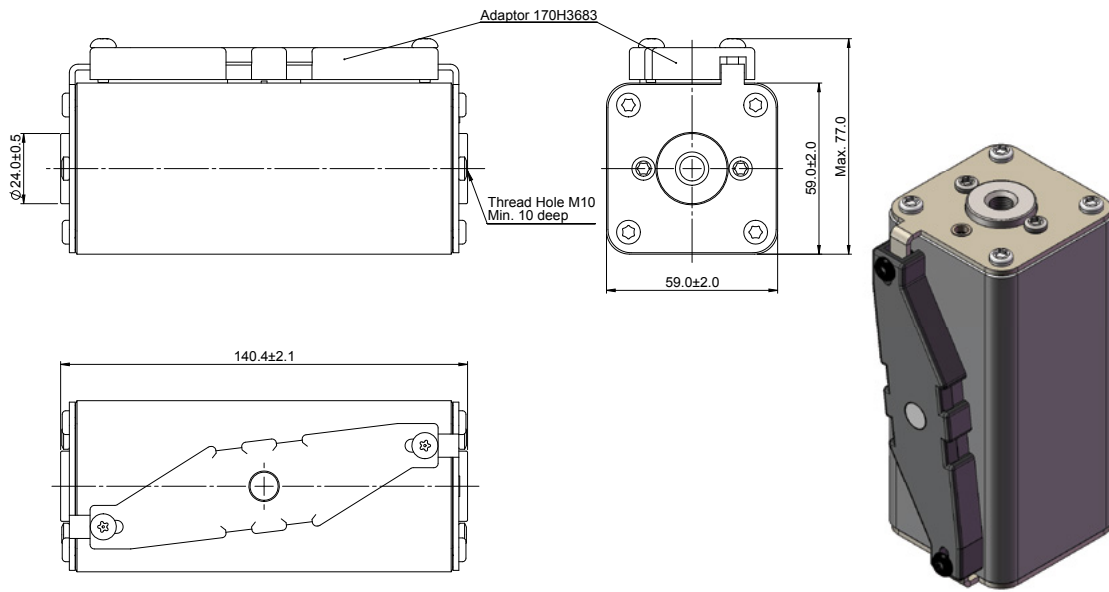

### Dimensions (mm) - 2TN/170 (DIN)

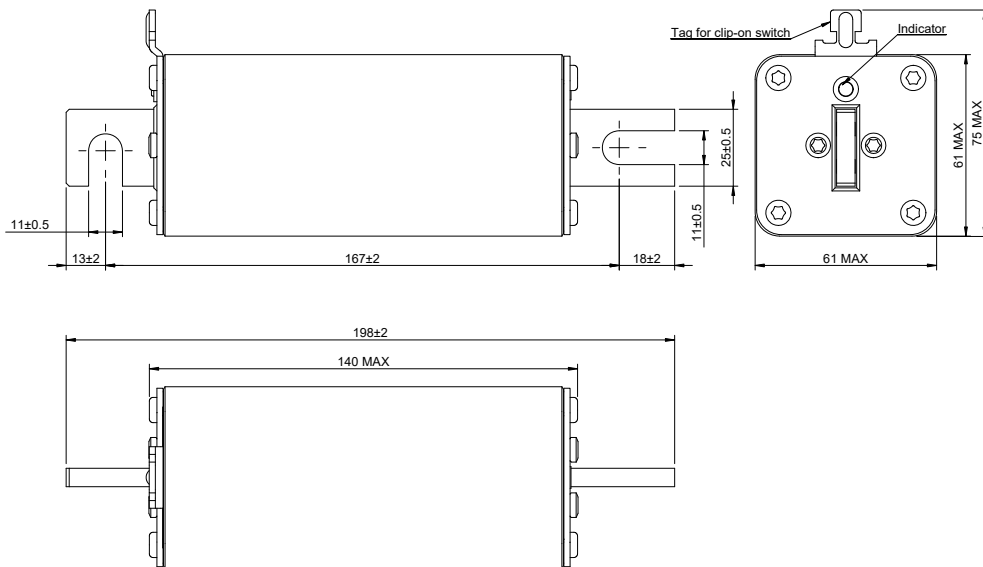

1500 V d.c. (IEC/UL) - 125 A to 500 A - 180D - Flush end, DIN and US Style contact fuse size 2

Dimensions (mm) - 2FTN/180 (US Style)

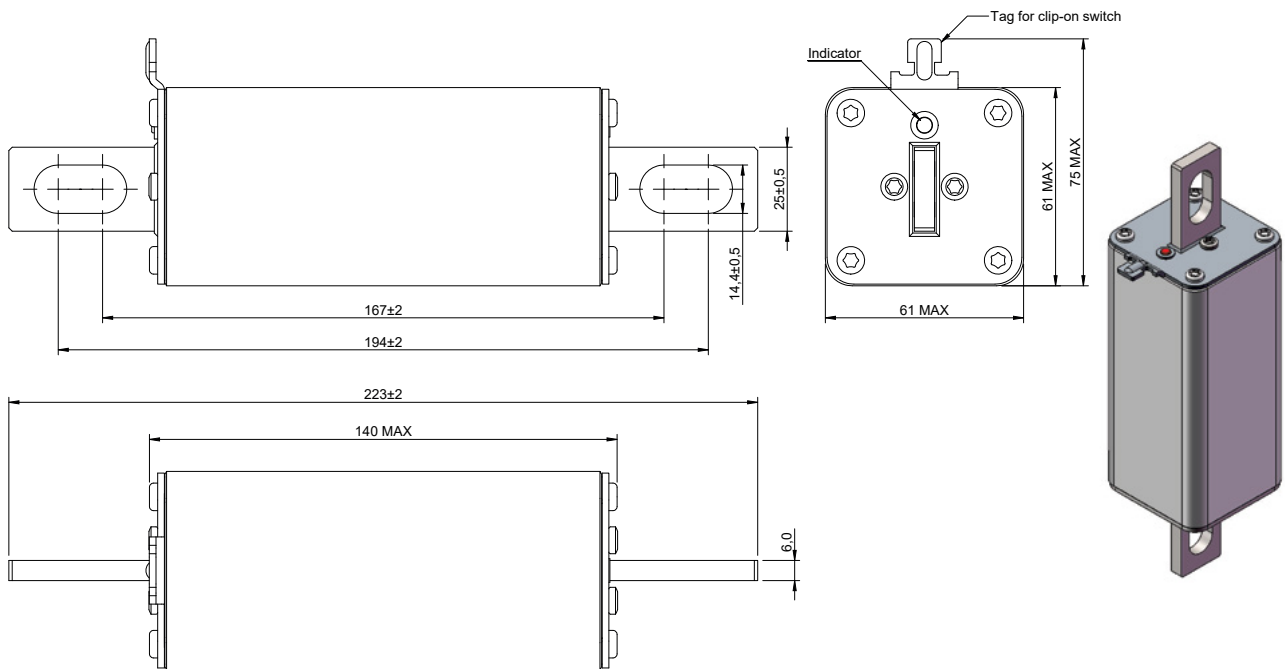

# Square body fuse links

## 1500 V d.c. (IEC/UL) - 125 A to 500 A - 180D - Flush end, DIN and US Style contact fuse size 2

### Time-current curve

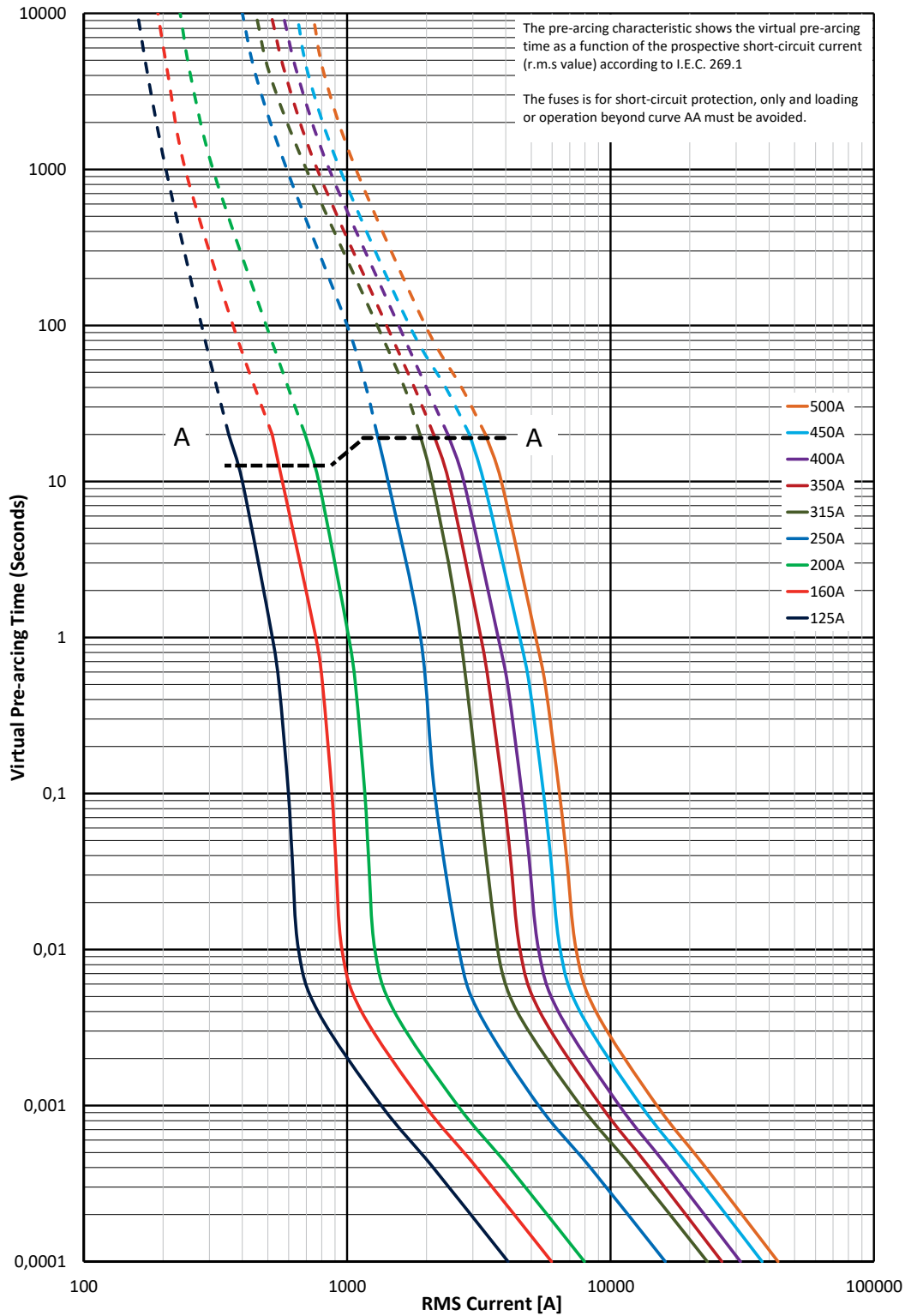

$K_b = 1$

Data sheet: [TD135026EN](#)

1500 V d.c. (IEC/UL) - 125 A to 500 A - 180D - Flush end, DIN and US Style contact fuse size 2

Peak let-through curve

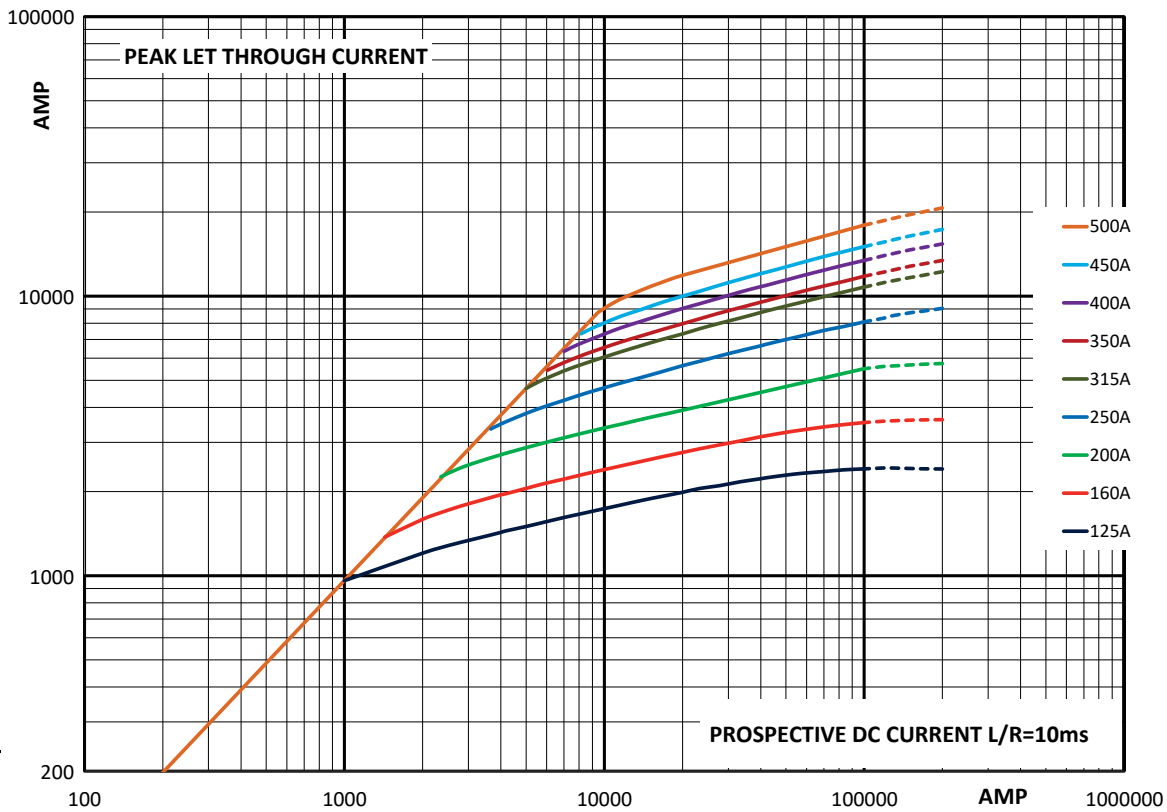

Watts losses

Watts loss at rated current is given in the electrical characteristics. The curve allows the calculation of the watts losses at load currents lower than the rated current. The correction factor,  $K_p$ , is given as a function of the RMS load current,  $I_b$ , in percent of the rated current.

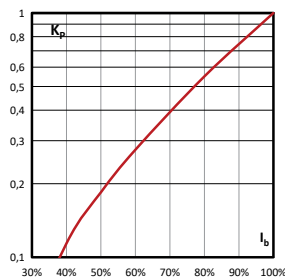

# Square body fuse links

## 1500 V d.c. (IEC/UL) - 100 A to 630 A - ESS3 and ESS3-NI - Size 3

### Specifications

#### Description

Eaton's Bussmann series 1500 V d.c. aR square body fuse links provide fast, reliable protection for modern DC systems including BESS, EV charging infrastructure, DC drives, and power conversion applications.

#### Technical data

- Rated voltage: 1500 V d.c. (IEC/UL)
- Rated current: 100 A to 630 A
- Breaking capacity: 250 kA at 4ms L/R
- Operating class: aR and aBat



#### Standards / Agency information

Designed and tested to IEC 60269 part 4 and 7, UL 248-13  
Recognised, RoHS compliant

#### Catalog numbers

Fuse body size	Rated voltage	Rated current (Amps)	Breaking capacity (kA at 4ms)	Minimum breaking current (A)	Pre-arcing I <sup>2</sup> t (A <sup>2</sup> Sec)	Power loss at In (W)	Catalog number	
3	1500 V d.c. (IEC/UL)	100	250	500	1200	55	ESS3-100	ESS3-100-NI
		125	250	625	2200	70	ESS3-125	ESS3-125-NI
		160	250	800	3900	85	ESS3-160	ESS3-160-NI
		200	250	1000	6600	90	ESS3-200	ESS3-200-NI
		250	250	1250	13,600	115	ESS3-250	ESS3-250-NI
		315	250	1575	24,100	120	ESS3-315	ESS3-315-NI
		350	250	1750	34,700	125	ESS3-350	ESS3-350-NI
		400	250	2000	60,000	135	ESS3-400	ESS3-400-NI
		450	250	2250	78,000	150	ESS3-450	ESS3-450-NI
		500	250	2500	96,000	170	ESS3-500	ESS3-500-NI
		550	250	2750	112,000	185	ESS3-550	ESS3-550-NI
		630	250	3150	172,000	198	ESS3-630	ESS3-630-NI

1500 V d.c. (IEC/UL) - 100 A to 630 A - ESS3 and ESS3-NI - Size 3

Dimensions (mm) - ESS3

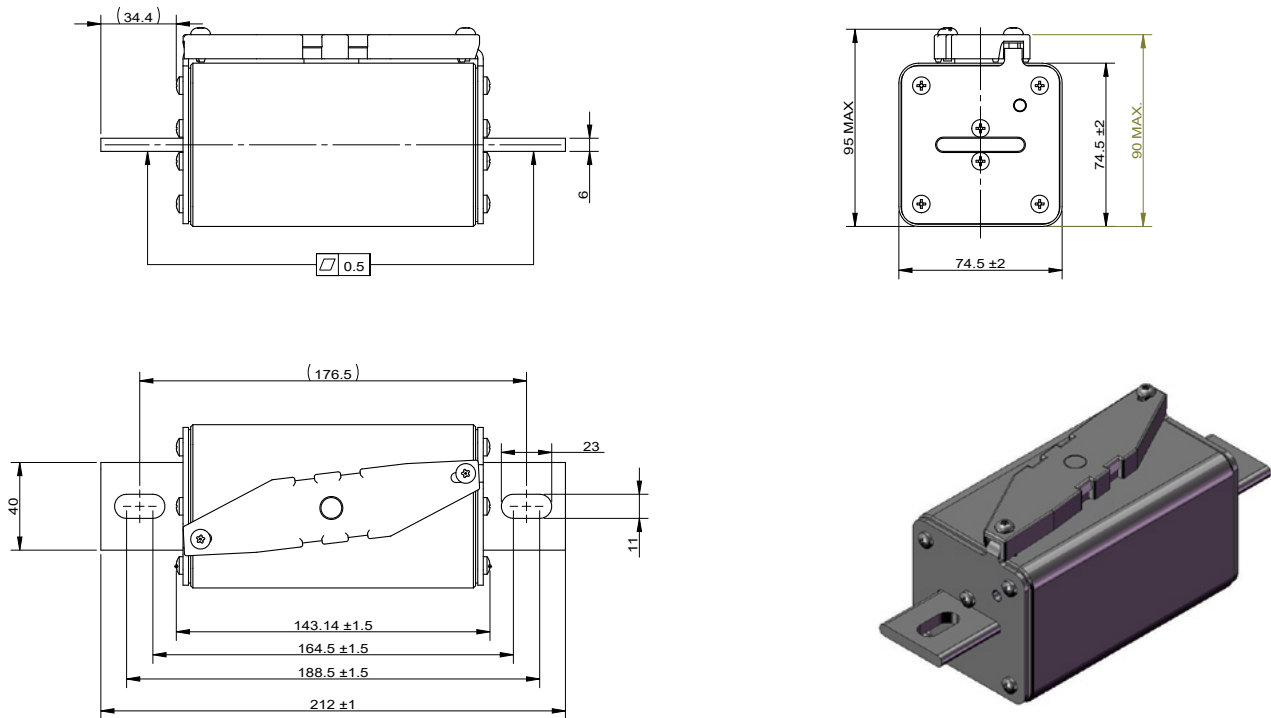

Dimensions (mm) - ESS3-NI

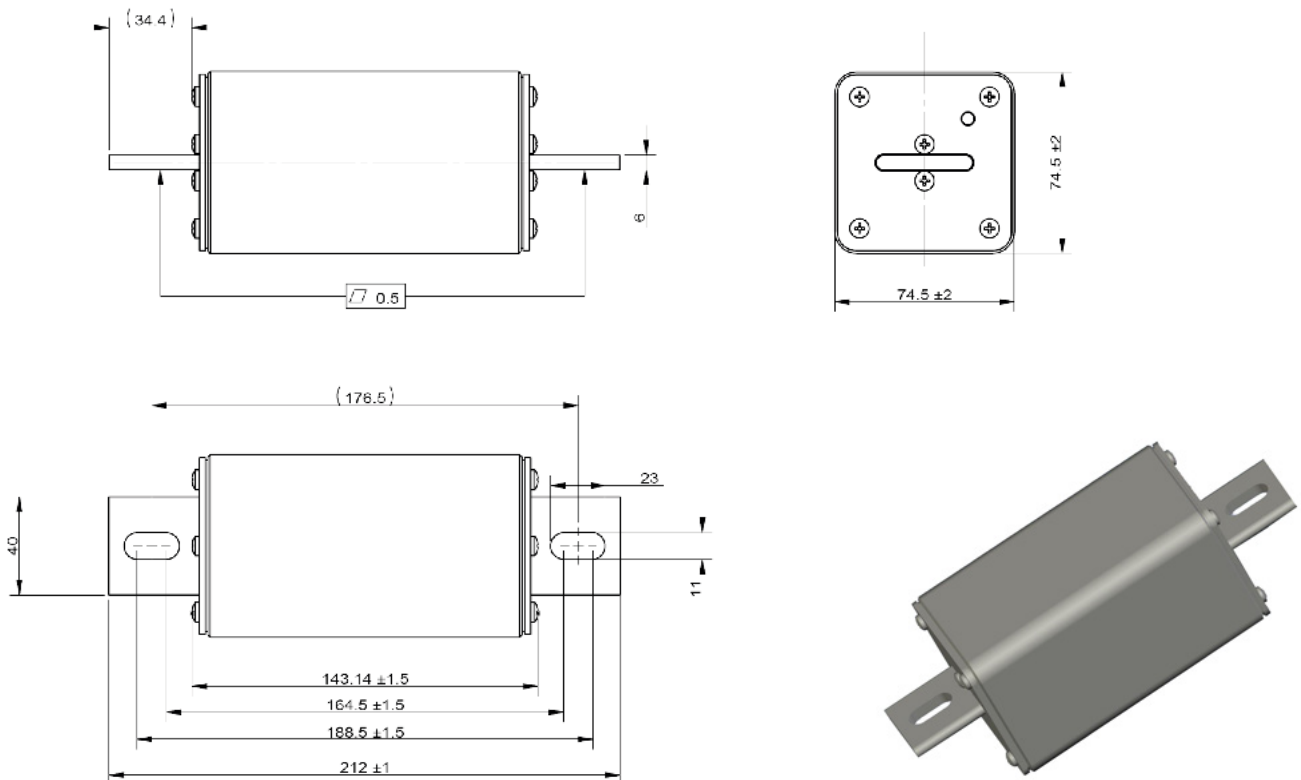

# Square body fuse links

## 1500 V d.c. (IEC/UL) - 100 A to 630 A - ESS3 and ESS3-NI - Size 3

### Time-current curve

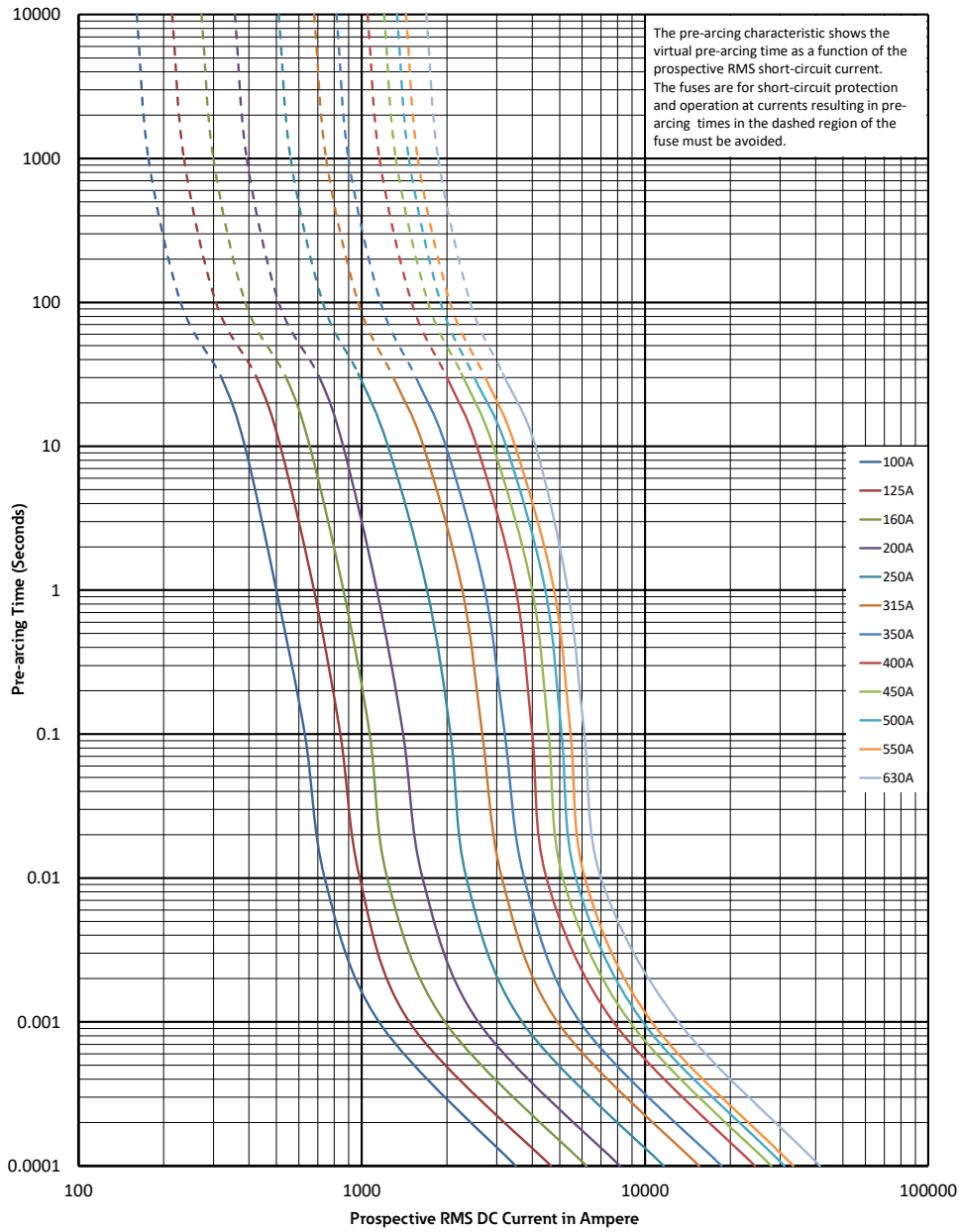

1500 V d.c. (IEC/UL) - 100 A to 630 A - ESS3 and ESS3-NI - Size 3

Peak let-through curve

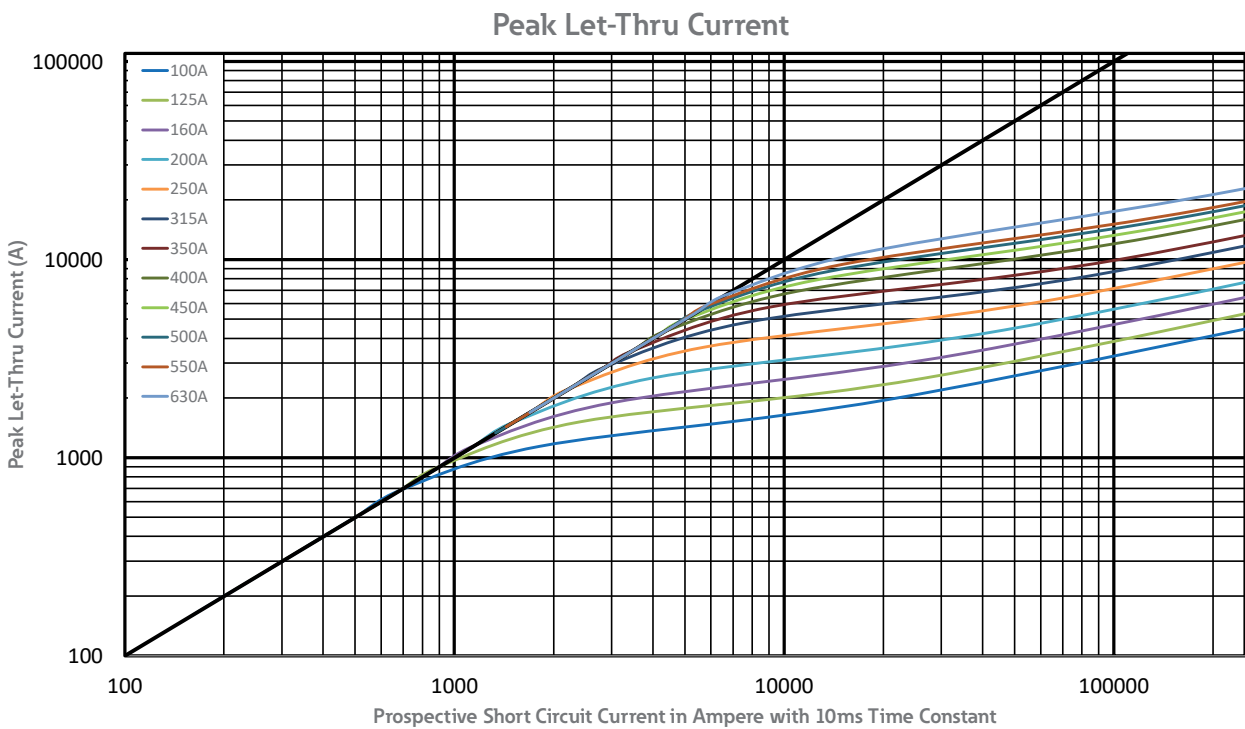

**Total clearing  $I^2t$**

The total clearing  $I^2t$  at rated voltage and tested DC time constant are given in electrical characteristics. For other voltages the clearing  $I^2t$  is found by multiplying by correction factor, K, given as a function of applied working voltages, E.

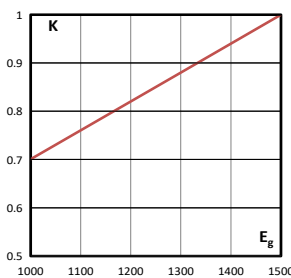

**Watts losses**

Watts loss at rated current is given in the electrical characteristics. The curve allows the calculation of the watts losses at load currents lower than the rated current. The correction factor,  $K_p$ , is given as a function of the RMS load current,  $I_b$ , in percent of the rated current.

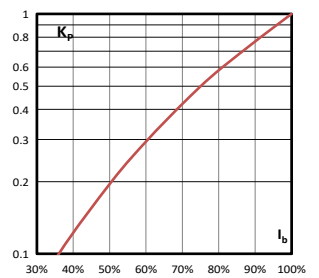

# Square body fuse links

## 1500 V d.c. (IEC/UL) - 350 A to 1400 A - 180D - Flush end, DIN and US Style contact fuse size 3

### Specifications

#### Description

Eaton's Bussmann series 1500 V d.c. aR and aBat square body fuse links provide fast, reliable protection for modern DC systems including BESS, EV charging infrastructure, DC drives, and power conversion applications.

#### Technical data

- Rated voltage: 1500 V d.c. (IEC/UL)
- Rated current: 350 A to 1400 A
- Breaking capacity:
  - 100 kA at 10ms L/R
  - 250 kA at 3ms L/R
- Operating class: aR and aBat



#### Compatible microswitch

- 170H0069

#### Standards / Agency information

Designed and tested to IEC 60269 part 4 and 7, UL 248-13  
Recognised, RoHS compliant

#### Catalog numbers

Fuse body size	Rated voltage	Rated current (Amps)	Breaking capacity	Minimum breaking current (A)	Pre-arcing I <sup>2</sup> t (A <sup>2</sup> Sec)	Power loss at I <sub>n</sub> (W)	Catalog numbers		
							Fuse type: 3BKN/130	Fuse type: 3KN/160	Fuse type: 3FKN/170
3	1500 V d.c. (IEC/UL)	350	100 kA at 10ms L/R	1400	25,000	132	180D8722	180D8735	180D8748
		400		1700	35,000	160	180D8723	180D8736	180D8749
		450	250 kA at 3ms L/R	2000	45,000	175	180D8724	180D8737	180D8750
		500		2400	65,000	180	180D8725	180D8738	180D8751
		550		2750	85,000	190	180D8726	180D8739	180D8752
		630		3400	130,000	200	180D8727	180D8740	180D8753
		700		4000	180,000	203	180D8728	180D8741	180D8754
		800		4850	265,000	205	180D8729	180D8742	180D8755
		900		5700	375,000	225	180D8730	180D8743	180D8756
		1000		6650	510,000	238	180D8731	180D8744	180D8757
		1100		7750	695,000	247	180D8732	180D8745	180D8758
		1250		9500	1,030,000	262	180D8733	180D8746	180D8759
1400	11,100	1,420,000	267	180D8734	180D8747	180D8760			

Data sheet: [TD135027EN](#)

1500 V d.c. (IEC/UL) - 350 A to 1400 A - 180D - Flush end, DIN and US Style contact fuse size 3

Dimensions (mm) - 3BKN/130

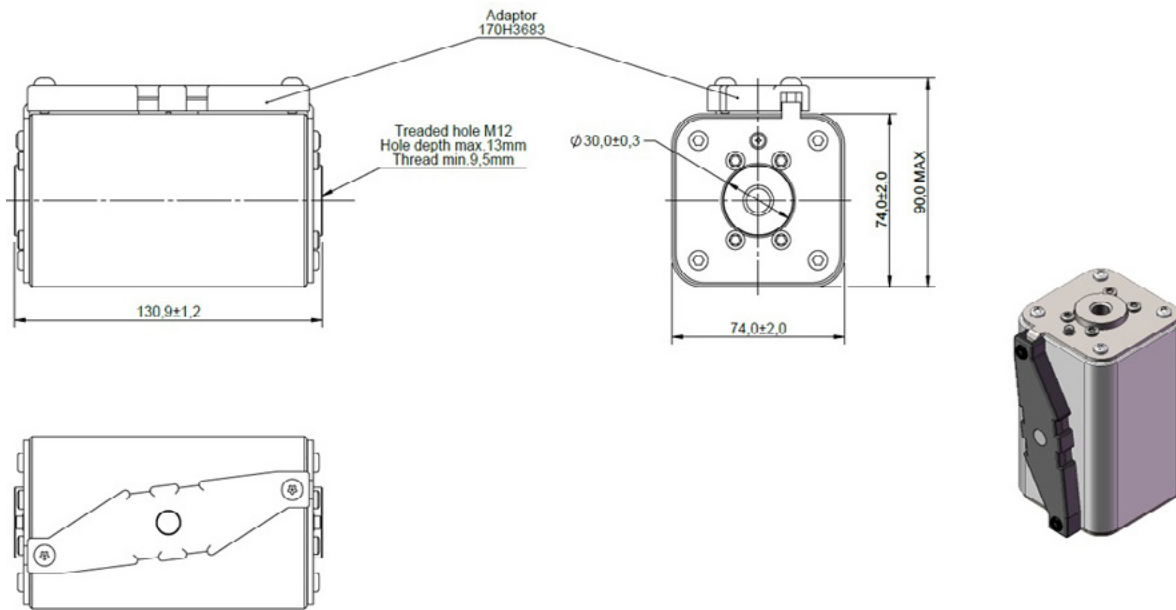

Dimensions (mm) - 3KN/160

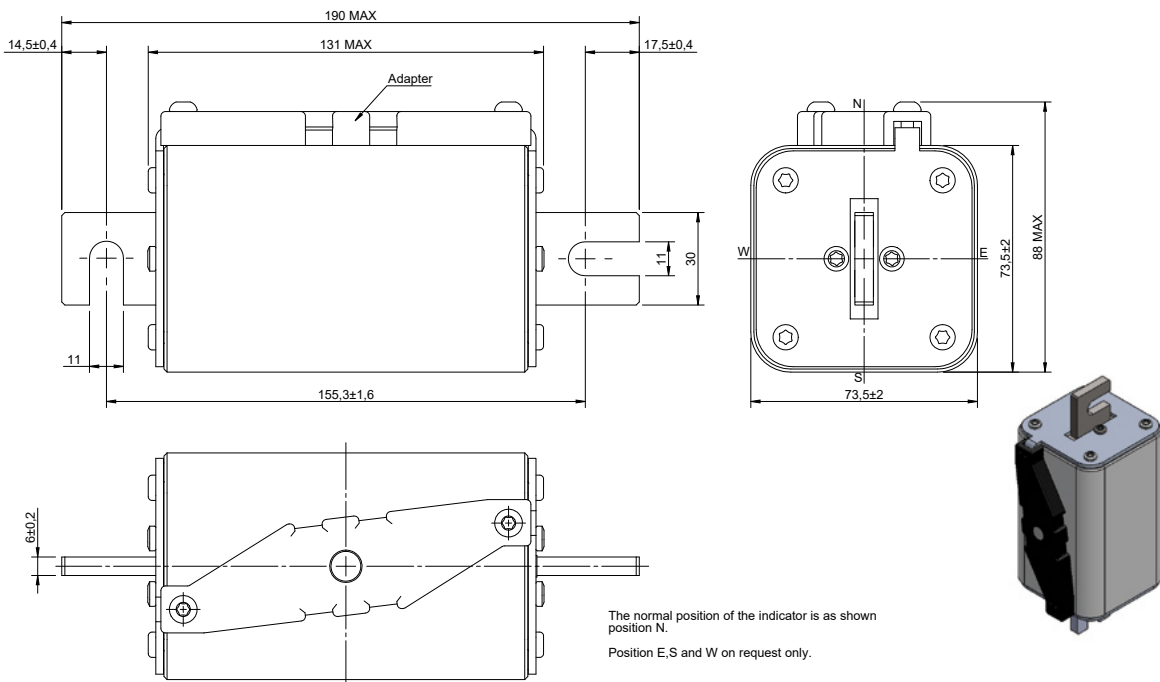

# Square body fuse links

1500 V d.c. (IEC/UL) - 350 A to 1400 A - 180D - Flush end, DIN and US Style contact fuse size 3

Dimensions (mm) - 3FKN/170

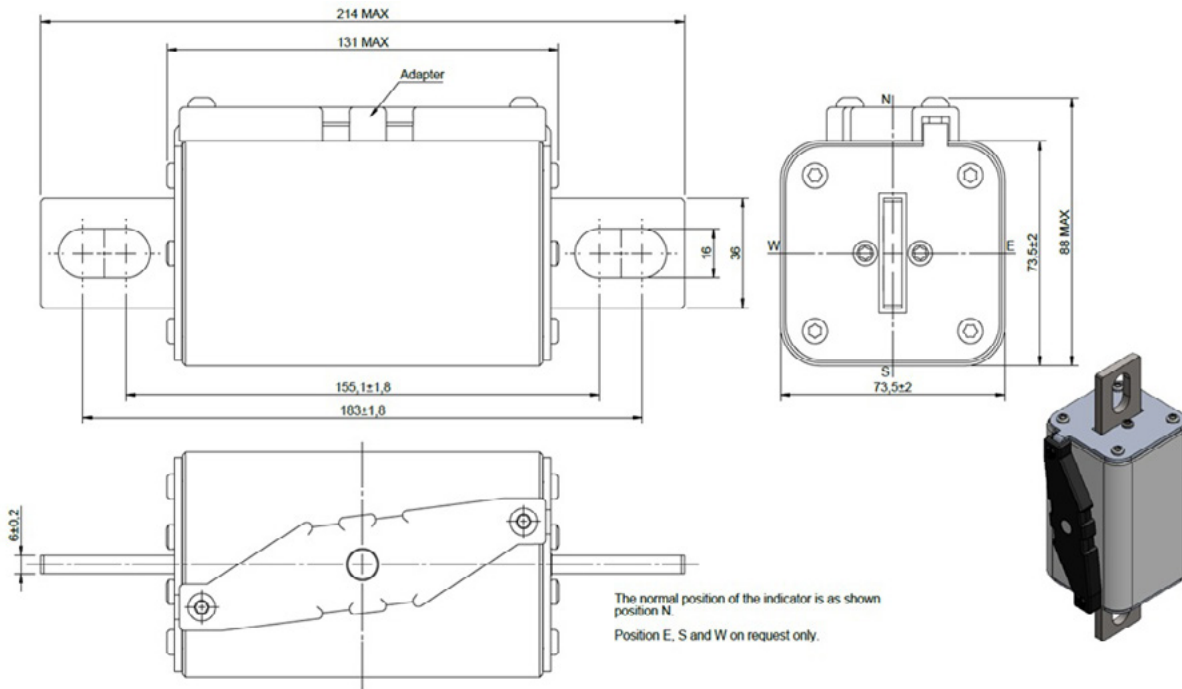

1500 V d.c. (IEC/UL) - 350 A to 1400 A - 180D - Flush end, DIN and US Style contact fuse size 3

Time-current curve

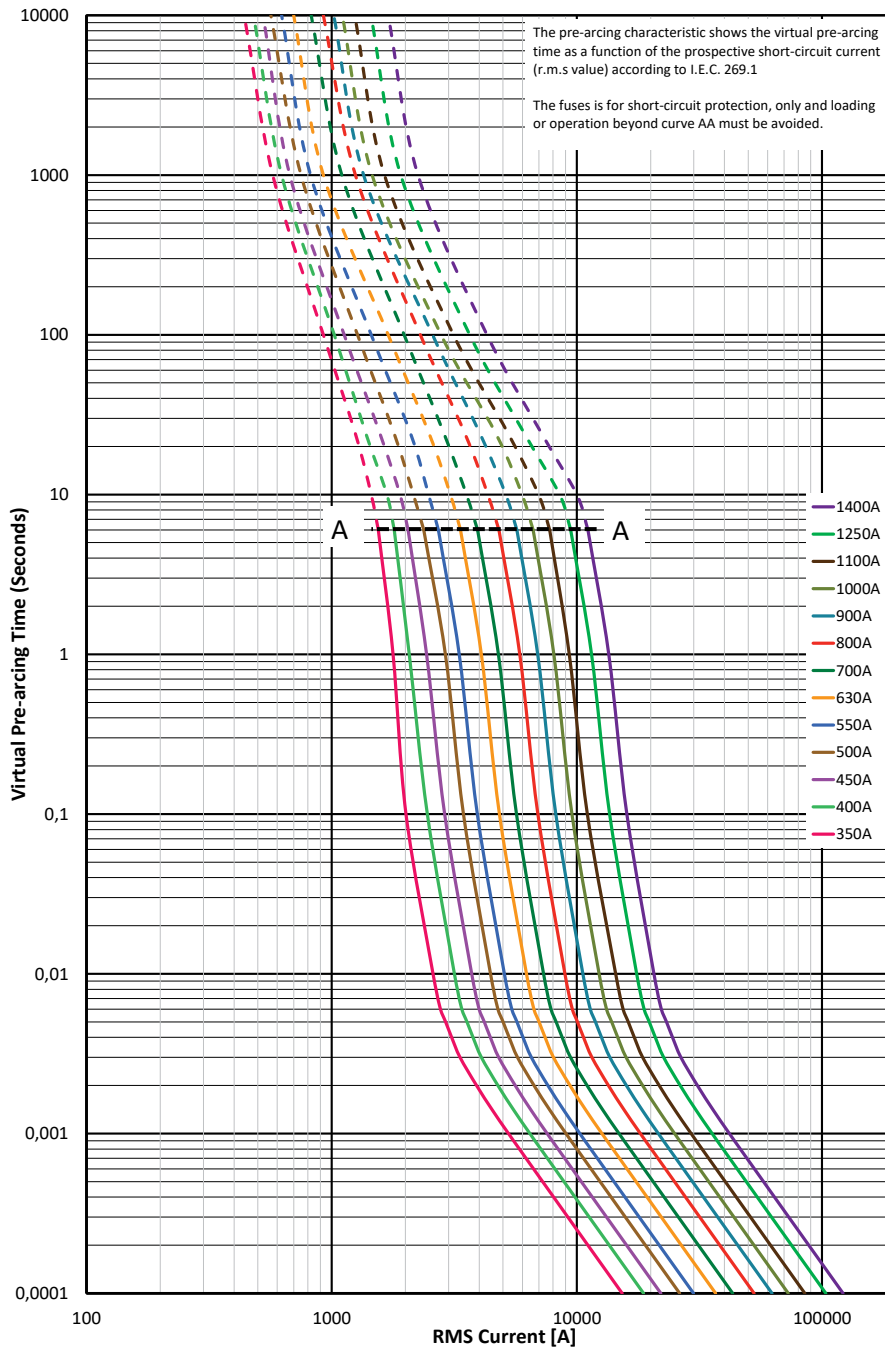

# Square body fuse links

1500 V d.c. (IEC/UL) - 350 A to 1400 A - 180D - Flush end, DIN and US Style contact fuse size 3

## Peak let-through curve

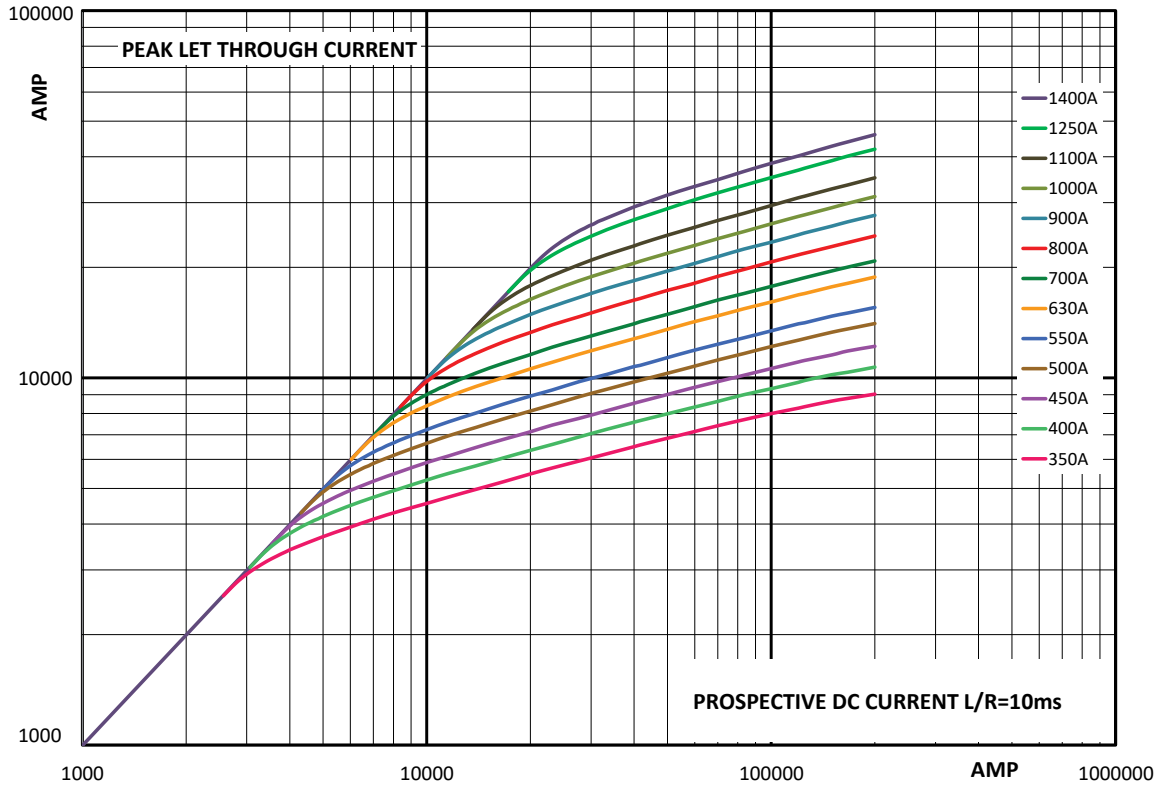

## Watts losses

Watts loss at rated current is given in the electrical characteristics. The curve allows the calculation of the watts losses at load currents lower than the rated current. The correction factor,  $K_p$ , is given as a function of the RMS load current,  $I_b$ , in percent of the rated current.

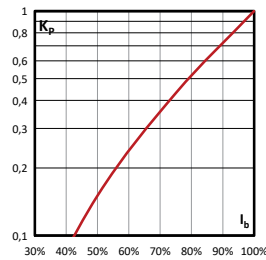

## 1500 V d.c. (IEC) - 250 A to 500 A - BSF-3XL - XL Style

### Specifications

#### Description

Eaton's Bussmann series XL battery storage fuses are specifically designed to protect and isolate battery array combiners and disconnects. These fuse links are capable of interrupting low overcurrents associated with faulted battery storage systems (reverse current, multi-array fault).

#### Technical data

- Rated voltage: 1500 V d.c.
- Rated current: 250 A to 500 A
- Operating class: gBat proposed for full range fuse links for protection of battery storage systems
- Breaking capacity: 100 kA
- Time constant: 4.5ms at 100 kA

#### Microswitches

- For bladed fuse links
  - 170H0236
  - 170H0238
- For bolted fuse links
  - 170H0069

#### Compatible fuse bases

- SD3L-S-PV

#### Standards / Agency information

IEC 60269-7



### Catalog numbers

Fuse link body size	Rated voltage	Rated current (Amps)	I <sup>2</sup> t (A <sup>2</sup> Sec)		Watts loss (W)		Catalog numbers	
			Pre-arcing	Total at 1500 V d.c.	0.7 I <sub>n</sub>	I <sub>n</sub>	Bladed version	Bolted version
3	1500 V d.c.	250	74,000	263,000	20	49	BSF-250G-3XL15	BSF-250G-3XL15-B
		315	150,000	533,000	21	52	BSF-315G-3XL15	BSF-315G-3XL15-B
		355	195,000	693,000	24	59	BSF-355G-3XL15	BSF-355G-3XL15-B
		400	296,000	1,060,000	24	61	BSF-400G-3XL15	BSF-400G-3XL15-B
		450	412,000	1,470,000	27	67	BSF-450G-3XL15	BSF-450G-3XL15-B
		500	532,000	1,890,000	29	73	BSF-500G-3XL15	BSF-500G-3XL15-B

# Square body fuse links

## 1500 V d.c. (IEC) - 250 A to 500 A - BSF-3XL - XL Style

### Dimensions (mm) - Size 3, bladed

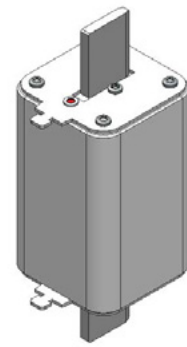
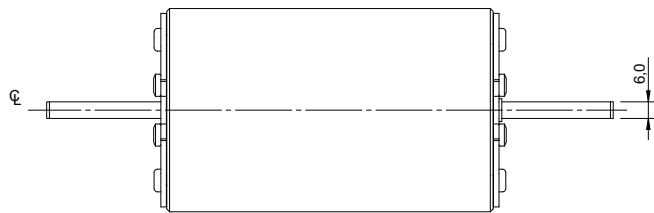
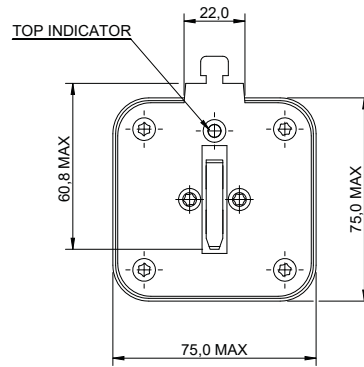
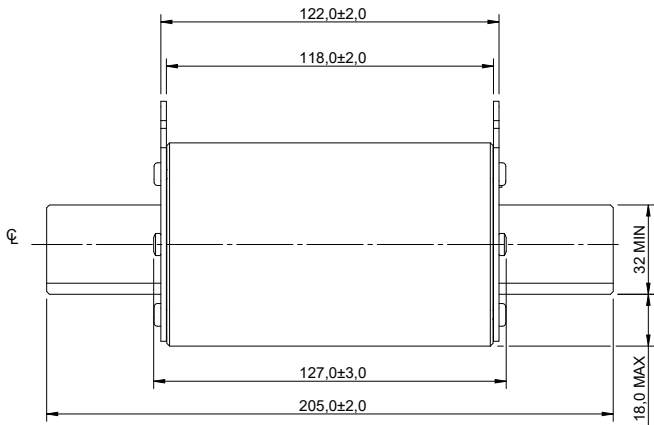

### Dimensions (mm) - Size 3, bolted

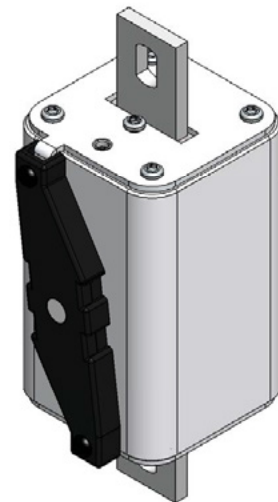
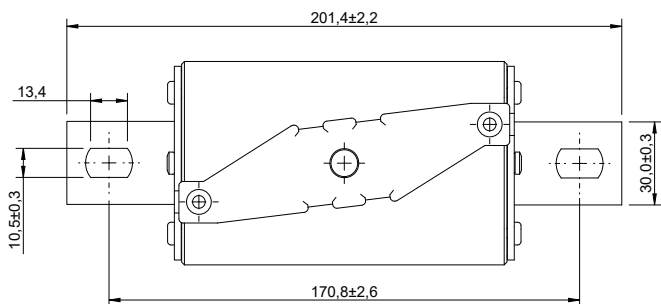
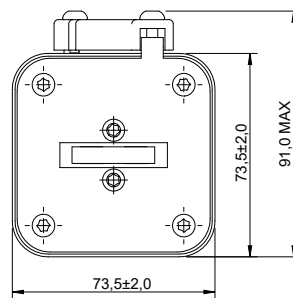
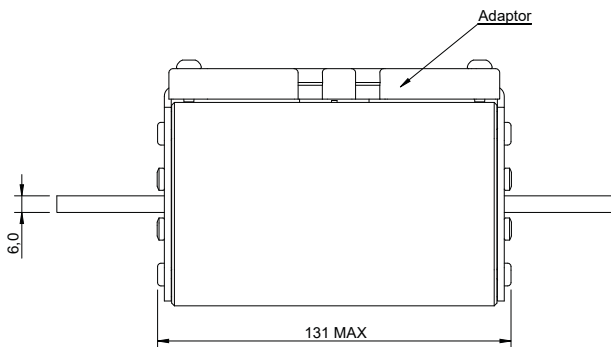

Data sheet: [135002](#)

1500 V d.c. (IEC) - 250 A to 500 A - BSF-3XL - XL Style

Time-current curve

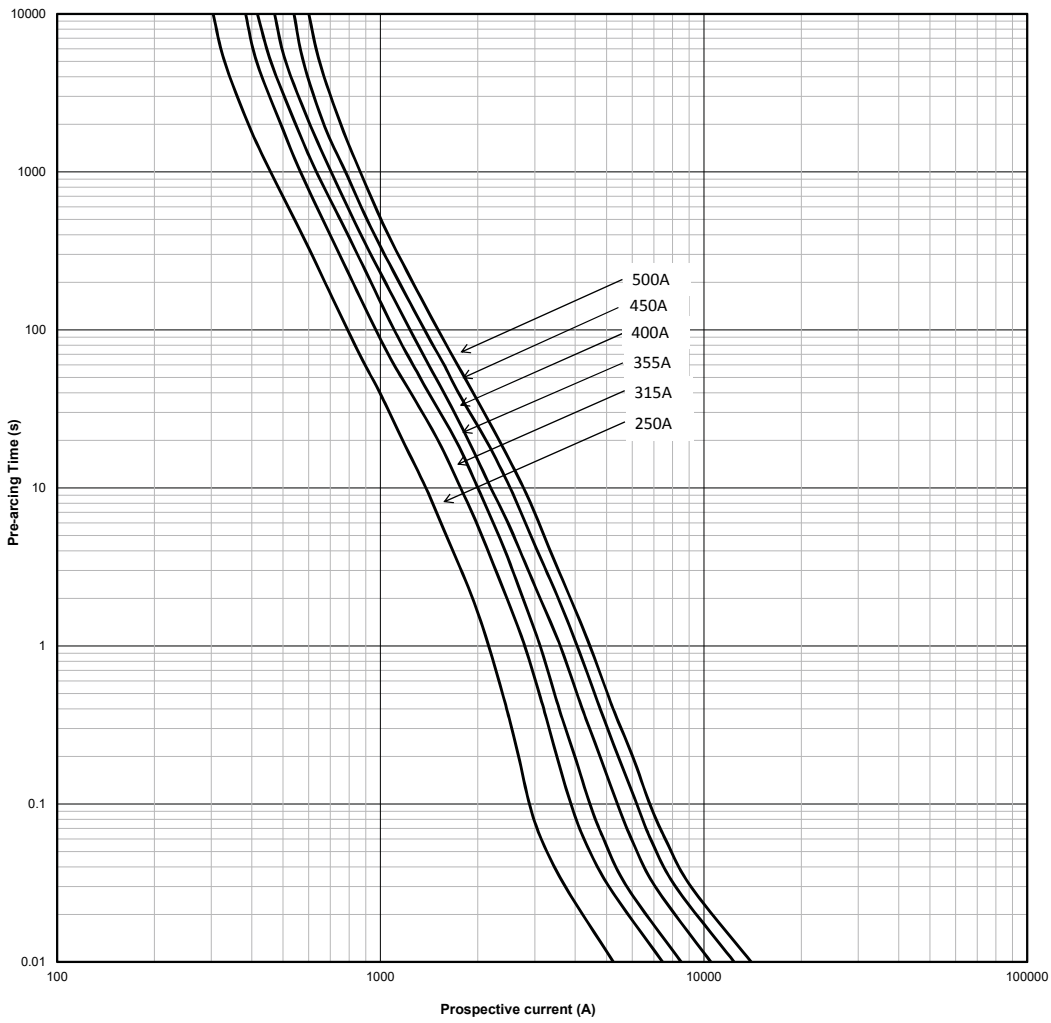

Temperature derating

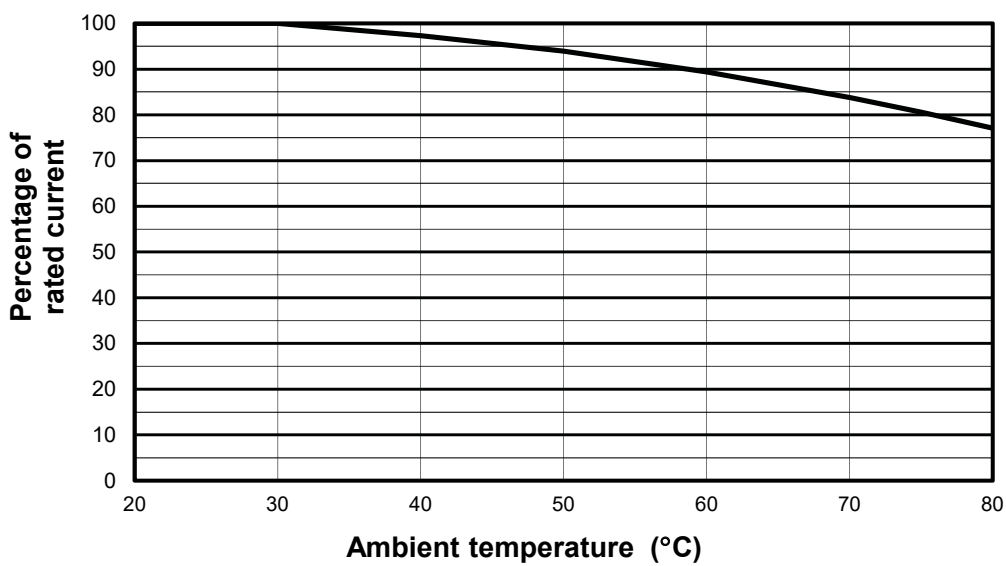

Data sheet: [135002](#)

# Square body fuse links

## 1500 V d.c. (IEC/UL) - 800 A to 1800 A - 180D - Flush end contact fuse body size 4

### Specifications

#### Description

Eaton's Bussmann series 1500 V d.c. aR and aBat square body fuse links provide fast, reliable protection for modern DC systems including BESS, EV charging infrastructure, DC drives, and power conversion applications.

#### Technical data

- Rated voltage: 1500 V d.c. (IEC/UL)
- Rated current: 800 A to 1800 A
- Breaking capacity:
  - 100 kA at 10ms L/R
  - 250 kA at 3ms L/R
- Operating class: aR and aBat

#### Compatible microswitch

- 170H0069

#### Standards / Agency information

Designed and tested to IEC 60269 part 4 and 7, UL 248-13  
Recognised, RoHS compliant

#### Catalog numbers

Fuse body size	Rated voltage	Rated current (Amps)	Breaking capacity (kA at 10ms)	Pre-arcing I <sup>2</sup> t (A <sup>2</sup> Sec)	Power loss at In (W)	Catalog number
4	1500 V d.c. (IEC/UL)	800	100	512,000	111	180D7462
		900	100	776,000	120	180D7463
		1000	100	1,000,000	164	180D7620
		1250	100	1,400,000	185	180D7698
		1500	100	2,500,000	228	180D7627
		1800	100	3,500,000	313	180D7477



#### Dimensions (mm)

Threaded hole M10, min. 10mm deep.  
Thread controlled with 6H gauge.  
Hole min. 11 deep.

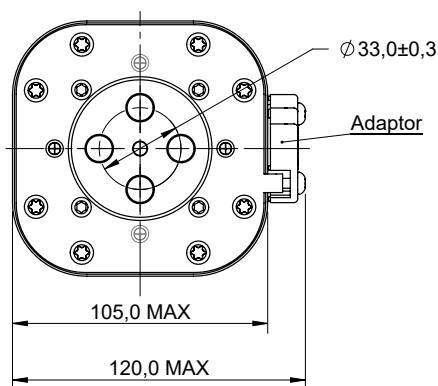
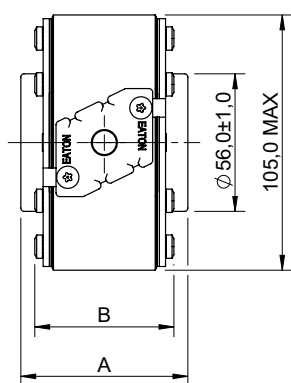

A	B
153.6 ± 2.4	142.6 ± 2.7

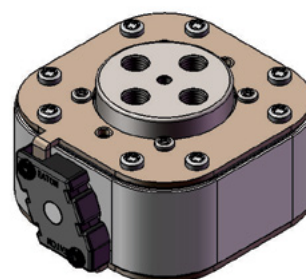

Data sheet: [TD135028EN](#)

1500 V d.c. (IEC/UL) - 800 A to 1800 A - 180D - Flush end contact fuse body size 4

Time-current curve

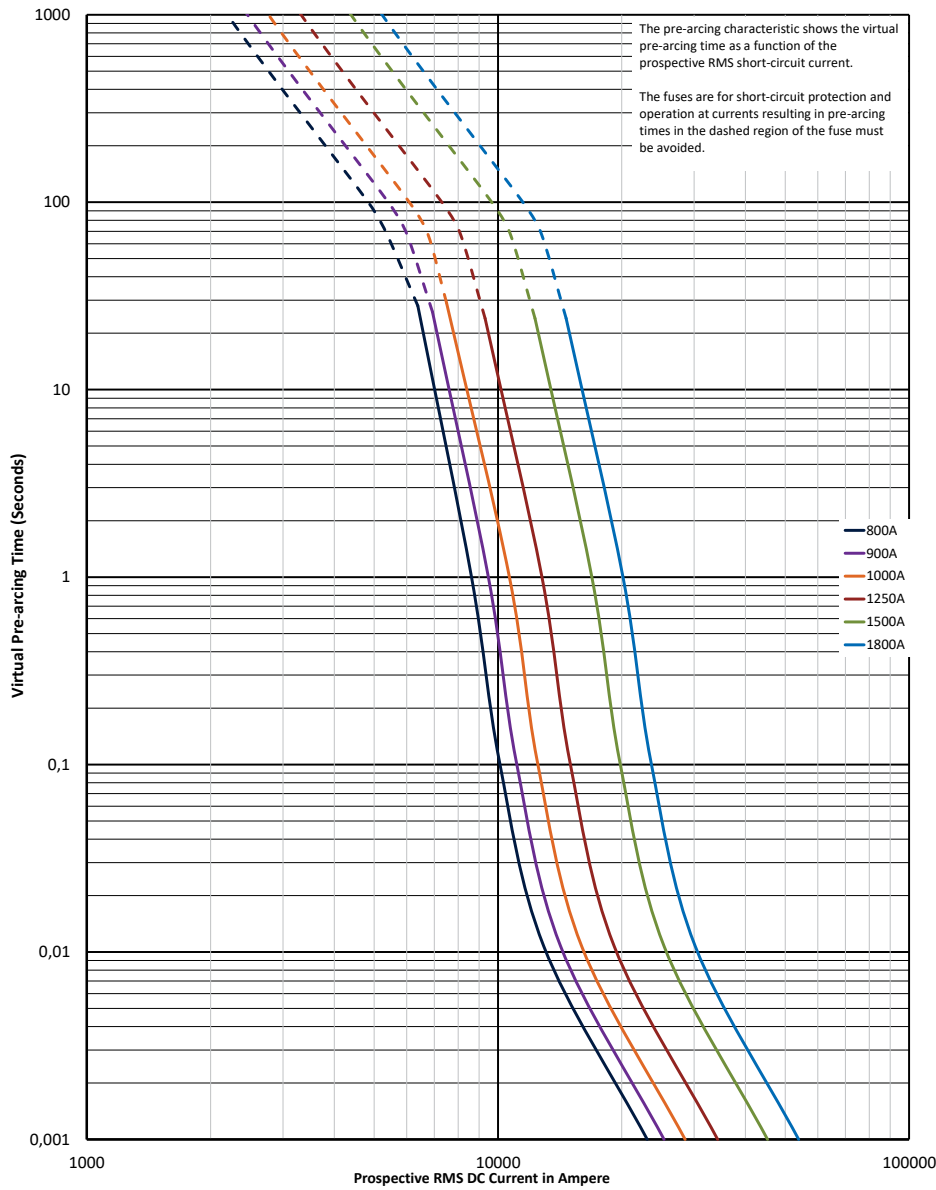

$K_b = 1$   $N = 1,5$

# Square body fuse links

## 1500 V d.c. (IEC/UL) - 800 A to 1800 A - 180D - Flush end contact fuse body size 4

Peak let-through curve

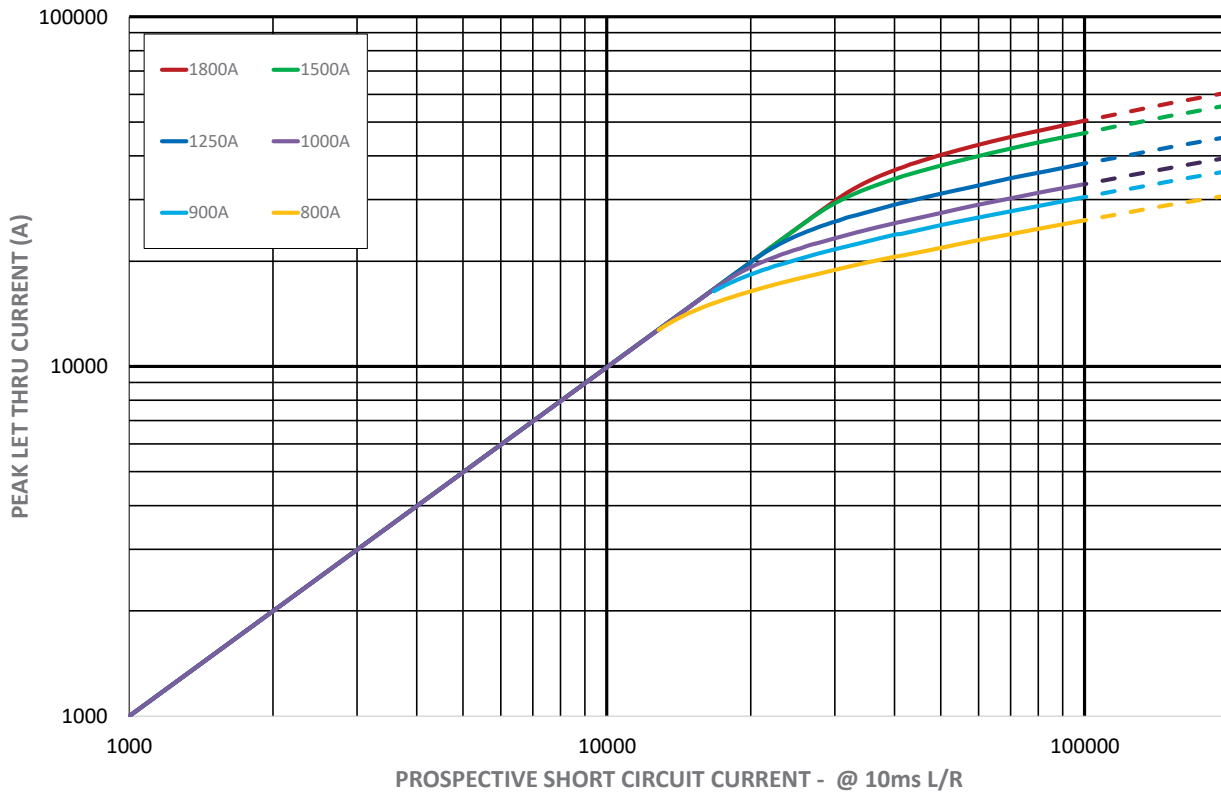

### Watts losses

Watts loss at rated current is given in the electrical characteristics. The curve allows the calculation of the watts losses at load currents lower than the rated current. The correction factor,  $K_p$ , is given as a function of the RMS load current,  $I_b$ , in percent of the rated current.

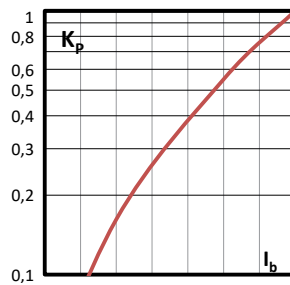

## 1500 V d.c. (IEC/UL) - 630 A to 1800 A - ESS5 - Size 4

### Specifications

#### Description

Eaton's Bussmann series 1500 V d.c. aR square body fuse links provide fast, reliable protection for modern DC systems including BESS, EV charging infrastructure, DC drives, and power conversion applications.

#### Technical data

- Rated voltage: 1500 V d.c. (IEC/UL)
- Rated current: 630 A to 1800 A
- Breaking capacity: 250 kA at 4ms L/R
- Operating class: aR and aBat



#### Standards / Agency information

Designed and tested to IEC 60269 part 4 and 7, UL 248-13  
Recognised, RoHS compliant

#### Catalog numbers

Fuse body size	Rated voltage	Rated current (Amps)	Breaking capacity (kA at 4ms)	Minimum breaking current (A)	Pre-arcing I <sup>2</sup> t (A <sup>2</sup> Sec)	Power loss at I <sub>n</sub> (W)	Catalog number
4	1500 V d.c. (IEC/UL)	630	250	5040	169,000	183	ESS5-630
		700	250	5600	200,000	192	ESS5-700
		800	250	6400	320,000	202	ESS5-800
		900	250	7200	467,000	212	ESS5-900
		1000	250	8000	658,000	233	ESS5-1000
		1100	250	8800	804,000	241	ESS5-1100
		1250	250	10,000	1,140,000	262	ESS5-1250
		1350	250	10,800	1,430,000	273	ESS5-1350
		1500	250	12,000	1,870,000	286	ESS5-1500
		1600	250	12,800	2,450,000	284	ESS5-1600
		1800	250	14,400	3,170,000	315	ESS5-1800

#### Dimensions (mm)

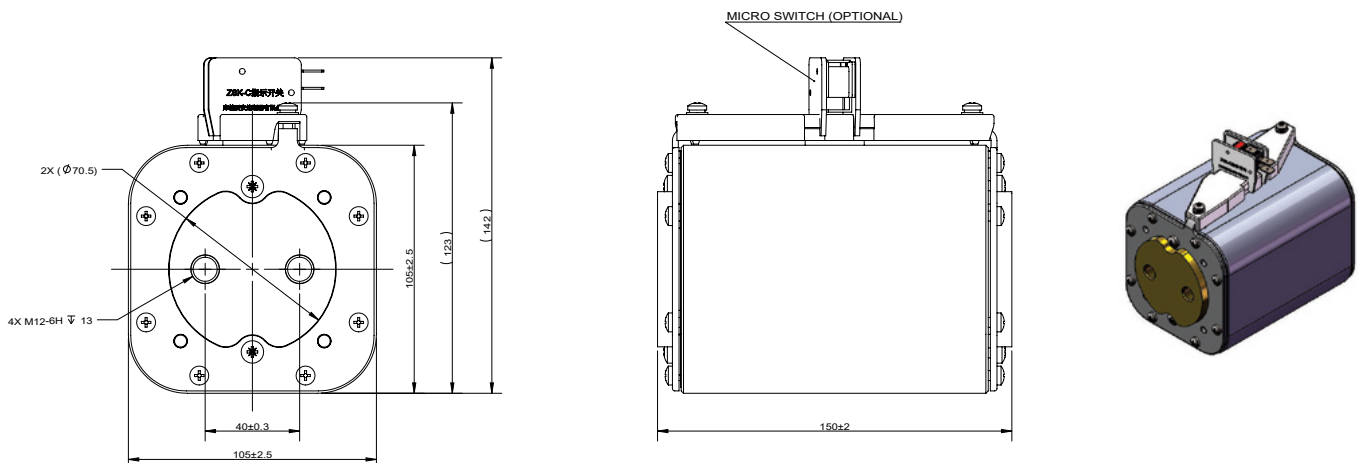

Data sheet: [TD135032EN](#)

# Square body fuse links

## 1500 V d.c. (IEC/UL) - 630 A to 1800 A - ESS5 - Size 4

### Time-current curve

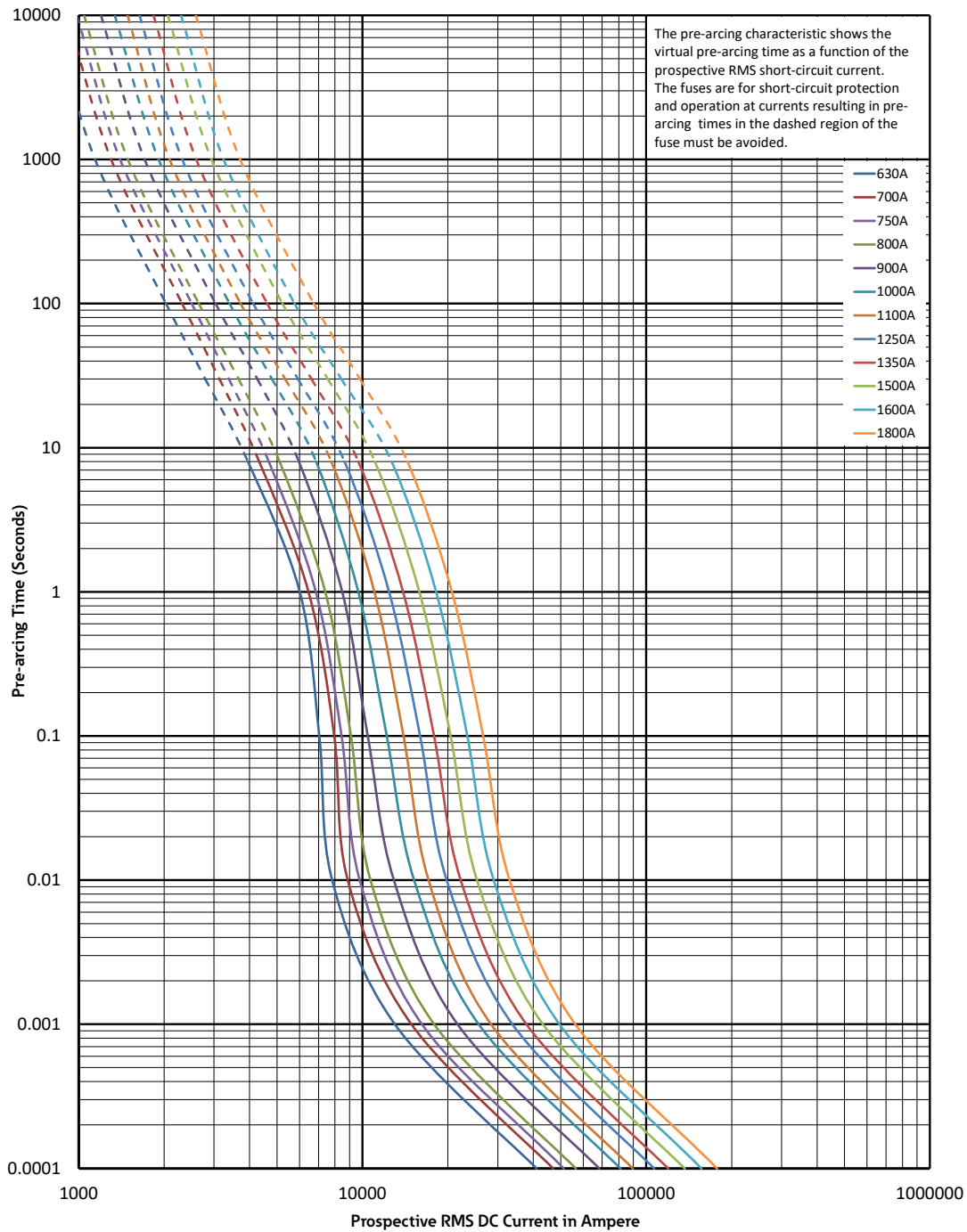

1500 V d.c. (IEC/UL) - 630 A to 1800 A - ESS5 - Size 4

Peak let-through curve

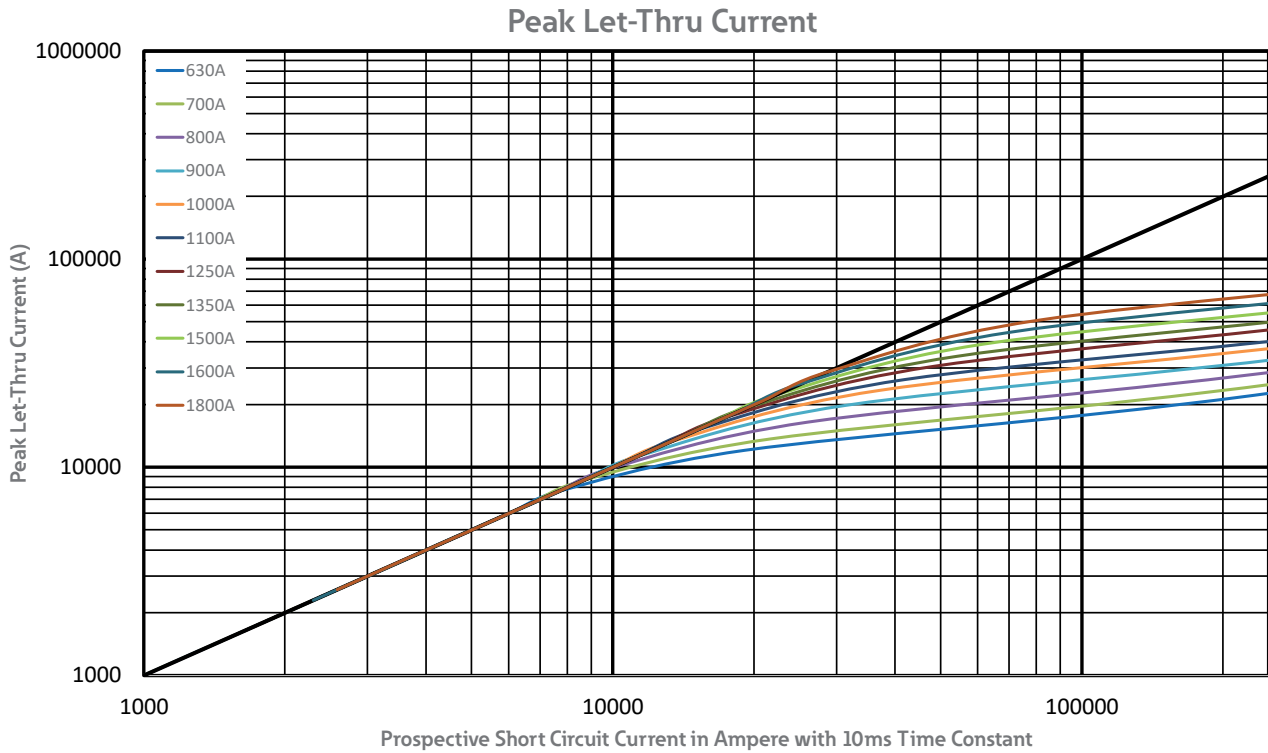

**Total clearing I<sup>2</sup>t**

The total clearing I<sup>2</sup>t at rated voltage and tested DC time constant are given in electrical characteristics. For other voltages the clearing I<sup>2</sup>t is found by multiplying by correction factor, K, given as a function of applied working voltages, E.

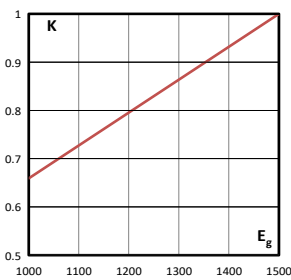

**Watts losses**

Watts loss at rated current is given in the electrical characteristics. The curve allows the calculation of the watts losses at load currents lower than the rated current. The correction factor, K<sub>p</sub>, is given as a function of the RMS load current, I<sub>b</sub>, in percent of the rated current.

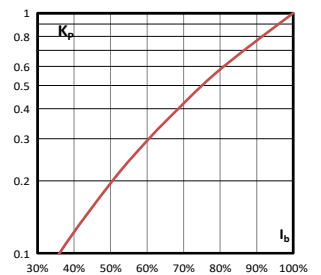

# Square body fuse links

## 1500 V d.c. (IEC/UL) - 1600 A to 3000 A - 180D - Size 24

### Specifications

#### Description

Eaton's Bussmann series 1500 V d.c. aR and aBat square body fuse links provide fast, reliable protection for modern DC systems including BESS, EV charging infrastructure, DC drives, and power conversion applications.

#### Technical data

- Rated voltage: 1500 V d.c. (IEC/UL)
- Rated current: 1600 A to 3000 A
- Breaking capacity: 250 kA at 3ms L/R
- Operating class: aR and aBat



#### Standards / Agency information

Designed and tested to IEC 60269 part 4, UL 248-13-Recognised, RoHS compliant

#### Catalog numbers

Fuse body size	Rated voltage	Rated current (Amps)	Breaking capacity (kA at 3ms)	Minimum breaking current (A)	Pre-arcing I <sup>2</sup> t (A <sup>2</sup> Sec)	Power loss at I <sub>n</sub> (W)	Catalog number
24	1500 V d.c. (IEC/UL)	1600	250	23,000	2,139,000	270	180D7739
		1800	250	27,500	3,044,000	300	180D7740
		2000	250	32,500	4,251,000	315	180D7741
		2200	250	37,500	5,660,000	330	180D7742
		2500	250	45,000	8,100,000	390	180D7743
		2800	250	53,500	11,407,000	410	180D7744
		3000	250	59,100	14,021,000	425	180D7745

#### Dimensions (mm)

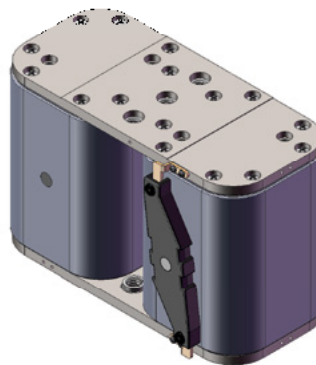
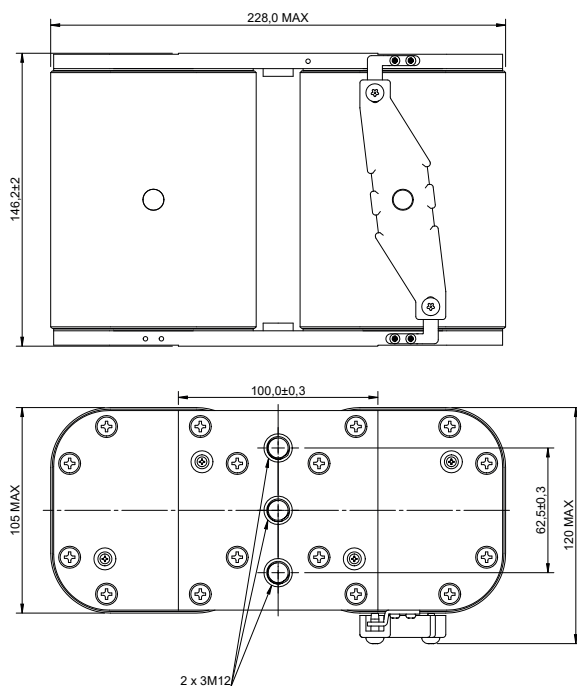

Data sheet: [TD135029EN](#)

1500 V d.c. (IEC/UL) - 1600 A to 3000 A - 180D - Size 24

Time-current curve

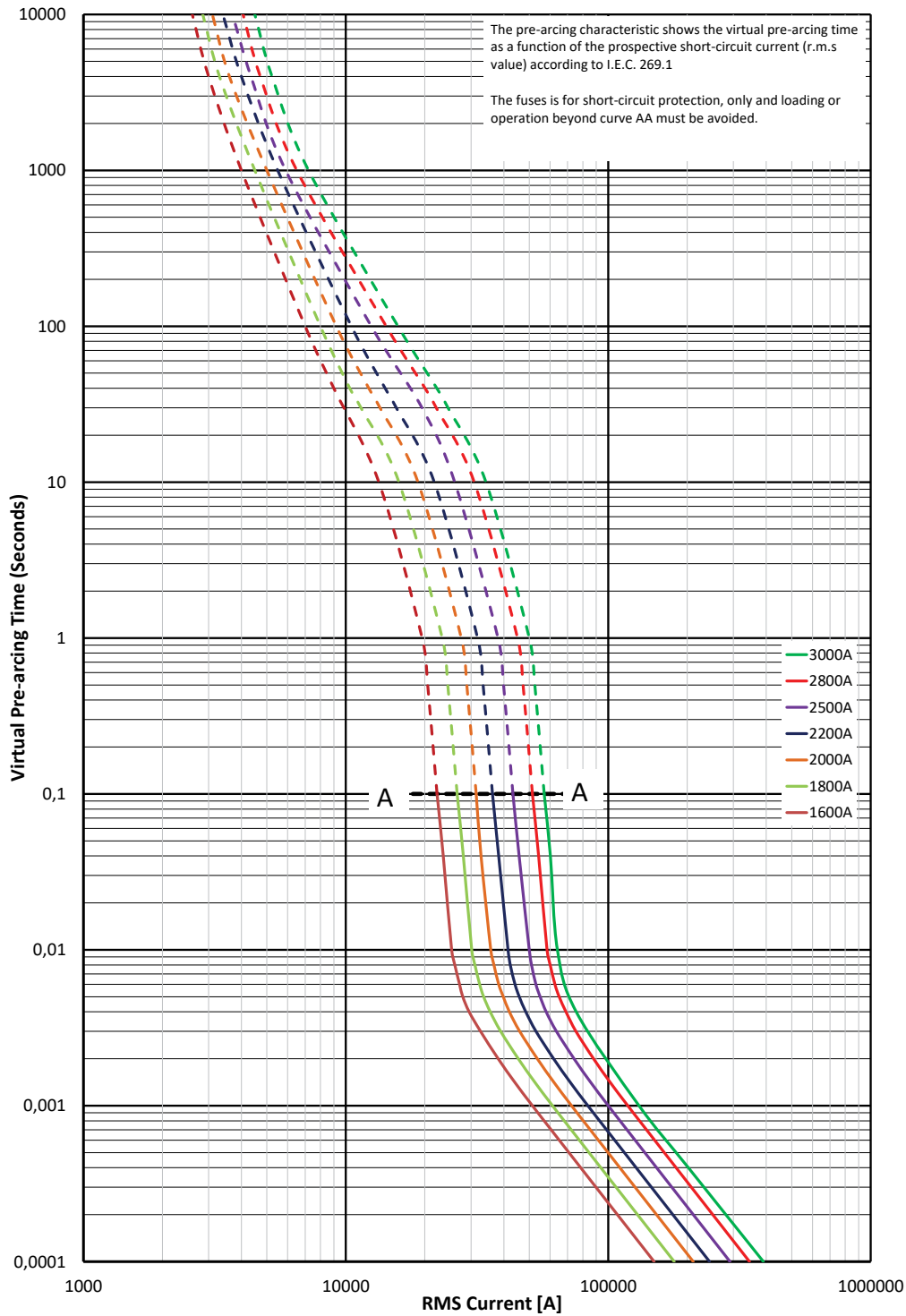

$K_b = 1$

# Square body fuse links

## 1500 V d.c. (IEC/UL) - 1600 A to 3000 A - 180D - Size 24

### Peak let-through curve

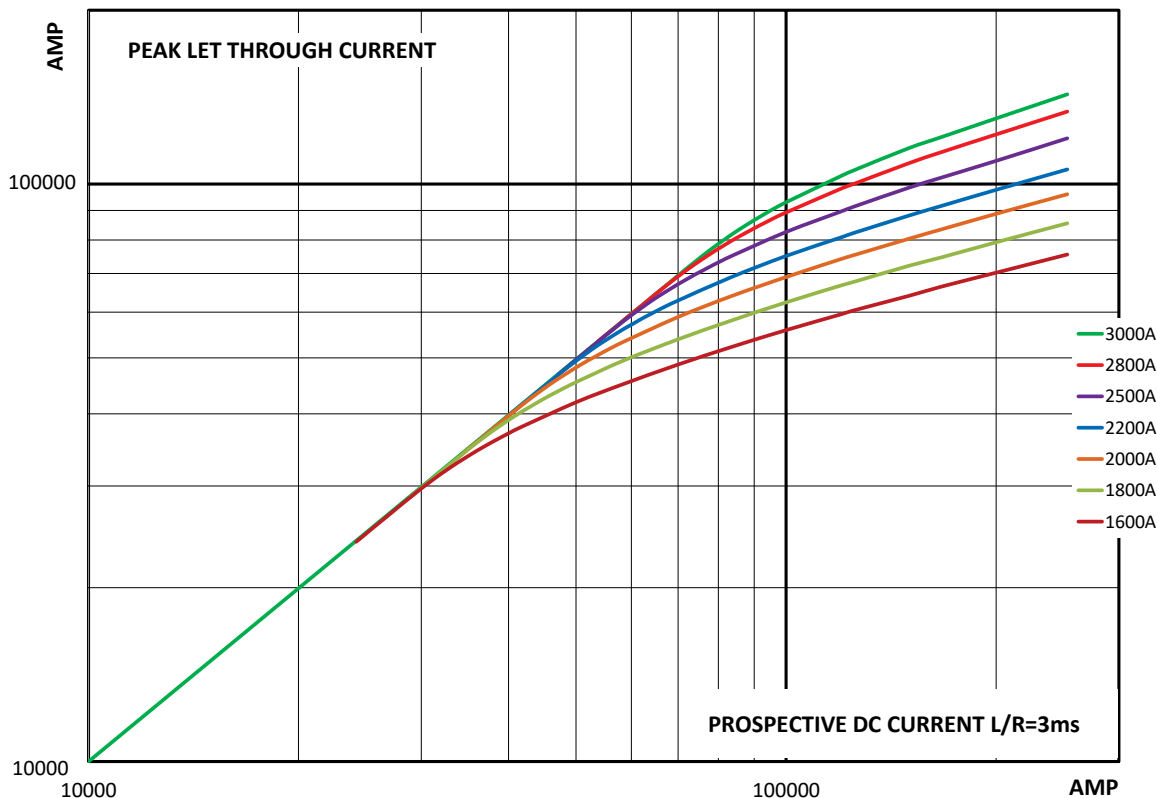

### Watts losses

Watts loss at rated current is given in the electrical characteristics. The curve allows the calculation of the watts losses at load currents lower than the rated current. The correction factor,  $K_p$ , is given as a function of the RMS load current,  $I_b$ , in percent of the rated current.

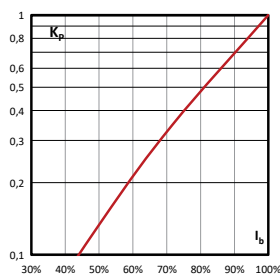

## 2000 V d.c. Battery Energy Storage System (BESS) fuses

DC applications move toward higher voltages to enable more efficient power conversion systems. These next-generation systems demand high-speed overcurrent protection to ensure safety and reliability under extreme electrical conditions. Eaton's focus on 2000 V d.c. fuse technology addresses these requirements, supporting the evolution of modern DC architectures for applications such as energy storage systems (BESS) and high-performance converters.

Operating at 2000 V d.c. presents unique challenges for fuse design, including increased arc energy, insulation requirements, and thermal management. Eaton's advanced fuse technology addresses these challenges with robust construction, optimized arc quenching, and high interrupting ratings, ensuring reliable protection in demanding DC environments.

These fuses are developed in alignment with **the upcoming IEC 63523 and UL 248-21 standard**, which define requirements for fuses rated above 1500 V d.c., ensuring future-proof compliance and performance.

Whether for grid-scale energy storage, high-voltage DC links, or cutting-edge power conversion systems, Eaton's 2000Vdc fuse range will deliver safety, reliability, and innovation for tomorrow's energy infrastructure.

### Technical data

- Rated voltage: 2000 V d.c.
- Rated current: various options available
- Operating class: aR and aBat
- Connection type: Flush end, DIN 43653 and US Bolted

### Standards / Agency information

IEC 63523 (Draft) and UL 248-21 (Draft), ROHS compliant

For inquiries related to your 2000 V d.c. BESS development, please contact [bulehighspeedtechnical@eaton.com](mailto:bulehighspeedtechnical@eaton.com)



# Photovoltaic fuse links, fuse bases and holders

## 600 V d.c. (UL) - 4 A to 30 A - PVM - 10 x 38 mm

### Specifications

#### Description

A range of UL 2579 fast-acting 600 V d.c. midget fuse links specifically designed to protect solar power systems in extreme ambient temperature, high cycling and low level fault rated current conditions (reverse rated current, multi-array fault).

#### Technical data

- Rated voltage: 600 V d.c. to UL 2579
- Rated current: 4 A to 30 A
- Breaking capacity: 50 kA DC (4 A to 30 A)

#### Compatible fuse holder

CHPV

#### Standards / Agency information

UL Listed 2579, Guide JFGA, File E335324, CSA Component Certified C22.2

#### Catalog numbers

Rated voltage	Rated current (Amps)	Power Loss (W)		Catalog numbers
		0.8 x I <sub>n</sub>	1 x I <sub>n</sub>	
600 V d.c. (UL)	4			PVM-4
	5			PVM-5
	6			PVM-6
	7			PVM-7
	8			PVM-8
	9			PVM-9
	10	1	1.9	PVM-10
	12			PVM-12
	15	1	1.7	PVM-15
	20			PVM-20
	25			PVM-25
	30	1.6	2.9	PVM-30



Please contact [FUSETECH@eaton.com](mailto:FUSETECH@eaton.com) for further information

#### Dimensions in (mm)

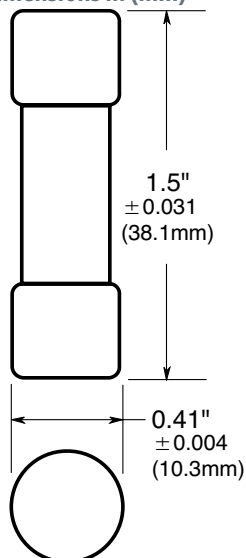

Data sheet: 2153

600 V d.c. (UL) - 4 A to 30 A - PVM - 10 x 38 mm

Time-current curve - 5 A to 30 A

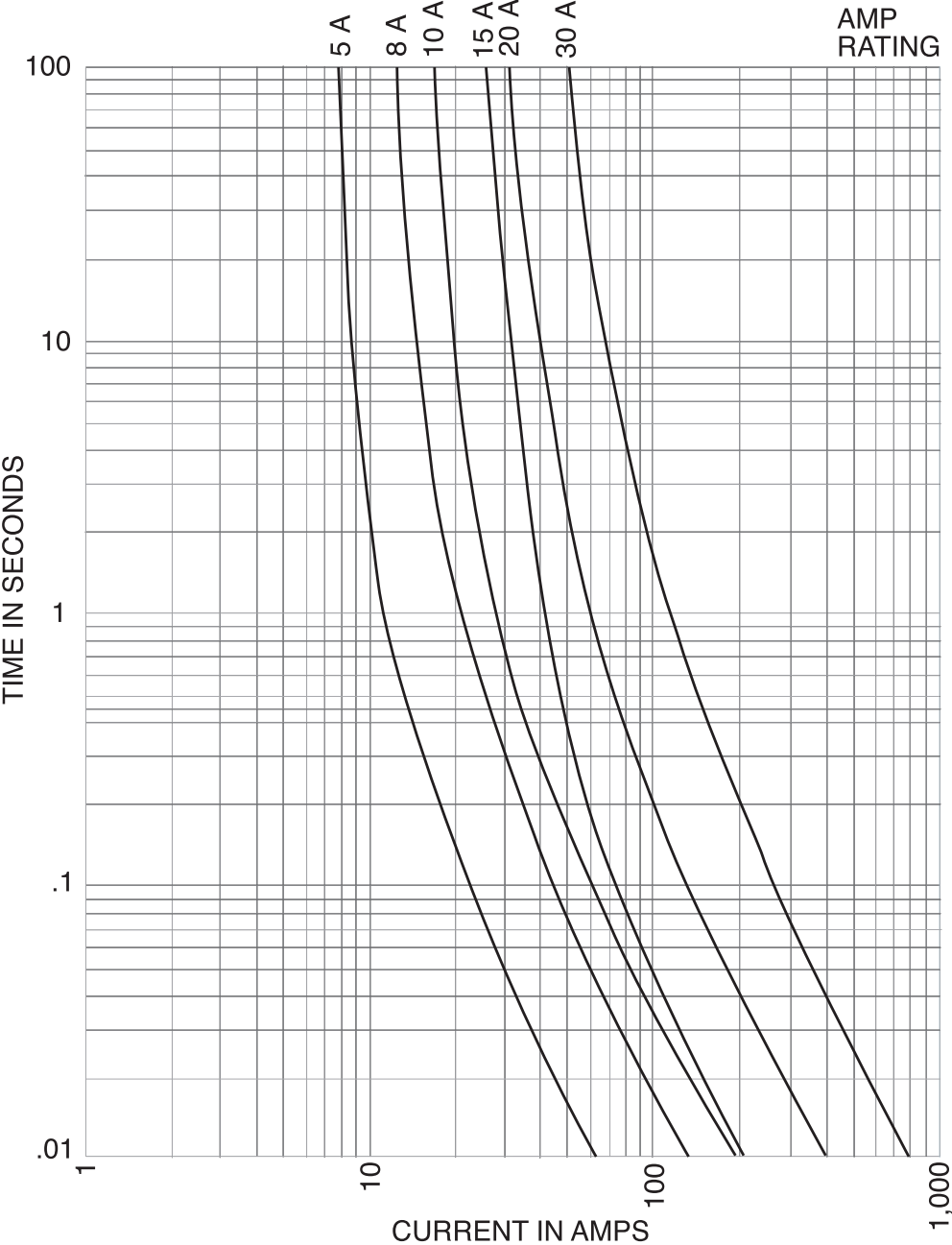

Please contact FUSETECH@eaton.com for further information

# Photovoltaic fuse links, fuse bases and holders

## 1000 V d.c. (IEC/UL) - 1 A to 20 A - PV-A10 - 10 x 38 mm

### Specifications

#### Description

A range of fuse links in a 10 x 38 mm package specifically designed for the protection and isolation of photovoltaic strings. The fuse links are capable of interrupting low over rated currents associated with faulted PV (reverse rated current, multi-array fault) string arrays.

#### Technical data

- Rated voltage: 1000 V d.c. (IEC/UL)
- Rated current: 1 A to 20 A
- Breaking capacity: 50 kA
- Operating class: gPV and UL PV fuse links

#### Compatible fuse holder

CHPV

#### Standards / Agency information

IEC 60269-6, UL Recognised 2579 (File number E335324), CSA, CCC (1-15A), RoHS compliant.



### Catalog numbers - Cylindrical and bolt fixing fuse links

Rated voltage	Rated current (Amps)	I <sup>2</sup> t (A <sup>2</sup> Sec)		Watts loss (W)		Catalog numbers	
		Pre-arcing	Total at 1000 V d.c.	0.8 I <sub>n</sub>	I <sub>n</sub>	Cylindrical	Bolt fixing
1000 V d.c. (UL/IEC)	1	0.2	0.4	0.8	1.5	PV-1A10F	PV-1A10-T
	2	1.2	4	0.6	1.0	PV-2A10F	PV-2A10-T
	2.5	3	9	0.6	1.0	PV-2-5A10F	PV-2-5A10-T
	3	4	11	0.8	1.3	PV-3A10F	PV-3A10-T
	3.5	6.6	18	0.9	1.4	PV-3-5A10F	PV-3-5A10-T
	4	9.5	26	1.0	1.5	PV-4A10F	PV-4A10-T
	5	19	50	1.0	1.6	PV-5A10F	PV-5A10-T
	6	30	90	1.1	1.8	PV-6A10F	PV-6A10-T
	8	3	32	1.2	2.1	PV-8A10F	PV-8A10-T
	10	7	70	1.2	2.3	PV-10A10F	PV-10A10-T
	12	12	120	1.5	2.7	PV-12A10F	PV-12A10-T
	15	15	160	1.7	2.9	PV-15A10F	PV-15A10-T
	16	19	200	1.8	3	PV-16A10F	PV-16A10-T
	20	34	350	2.1	3.6	PV-20A10F	PV-20A10-T

1000 V d.c. (IEC/UL) - 1 A to 20 A - PV-A10 - 10 x 38 mm

Catalog numbers - PCB fixing fuse links

Rated voltage	Rated current (Amps)	I <sup>2</sup> t (A <sup>2</sup> Sec)		Watts loss (W)		Catalog numbers		
		Pre-arcing	Total at 1000 V d.c.	0.8 I <sub>n</sub>	I <sub>n</sub>	PCB fixing single pin	PCB fixing double pin	PCB fixing double pin silver cap
1000 V d.c. (UL/IEC)	1	0.2	0.4	0.8	1.5	PV-1A10-1P	PV-1A10-2P	PV-1A10-2P-S
	2	1.2	4	0.6	1.0	PV-2A10-1P	PV-2A10-2P	PV-2A10-2P-S
	2.5	3	9	0.6	1.0	PV-2-5A10-1P	PV-2-5A10-2P	PV-2-5A10-2P-S
	3	4	11	0.8	1.3	PV-3A10-1P	PV-3A10-2P	PV-3A10-2P-S
	3.5	6.6	18	0.9	1.4	PV-3-5A10-1P	PV-3-5A10-2P	PV-3-5A10-2P-S
	4	9.5	26	1.0	1.5	PV-4A10-1P	PV-4A10-2P	PV-4A10-2P-S
	5	19	50	1.0	1.6	PV-5A10-1P	PV-5A10-2P	PV-5A10-2P-S
	6	30	90	1.1	1.8	PV-6A10-1P	PV-6A10-2P	PV-6A10-2P-S
	8	3	32	1.2	2.1	PV-8A10-1P	PV-8A10-2P	PV-8A10-2P-S
	10	7	70	1.2	2.3	PV-10A10-1P	PV-10A10-2P	PV-10A10-2P-S
	12	12	120	1.5	2.7	PV-12A10-1P	PV-12A10-2P	PV-12A10-2P-S
	15	15	160	1.7	2.9	PV-15A10-1P	PV-15A10-2P	PV-15A10-2P-S
	16	19	200	1.8	3	PV-16A10-1P	PV-16A10-2P	PV-16A10-2P-S
	20	34	350	2.1	3.6	PV-20A10-1P	PV-20A10-2P	PV-20A10-2P-S

Dimensions (mm) - PV-\*\*A10F, Cylindrical

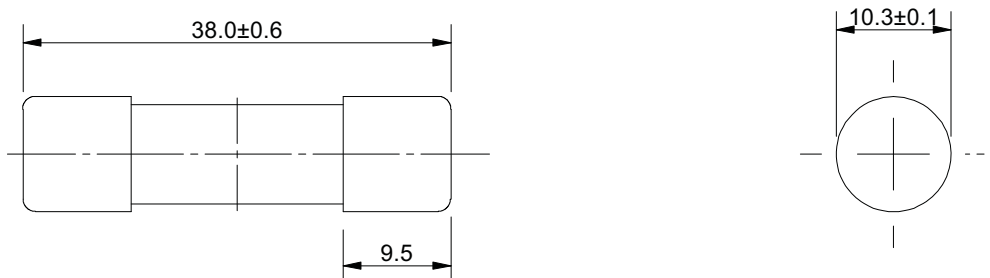

Dimensions (mm) - PV-\*\*A10-xP, PCB fixing

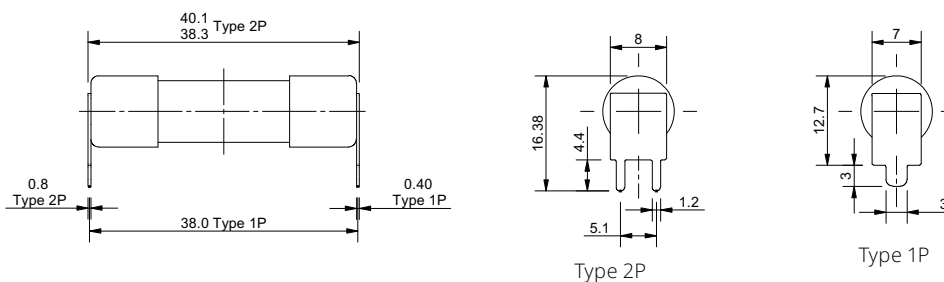

Dimensions (mm) - PV-\*\*A10-T, Bolt fixing

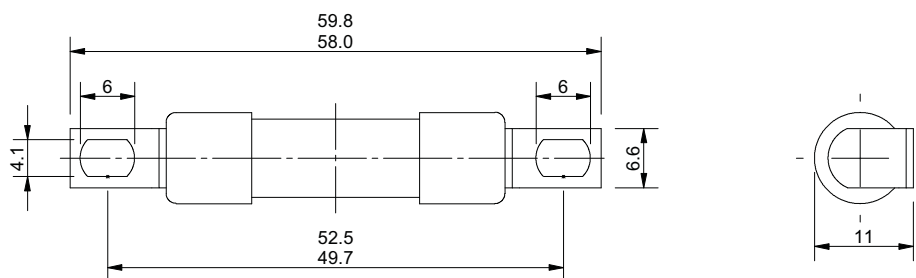

Data sheet: [720110](#)

# Photovoltaic fuse links, fuse bases and holders

## 1000 V d.c. (IEC/UL) - 1 A to 20 A - PV-A10 - 10 x 38 mm

Time-current curve - 1 A to 20 A

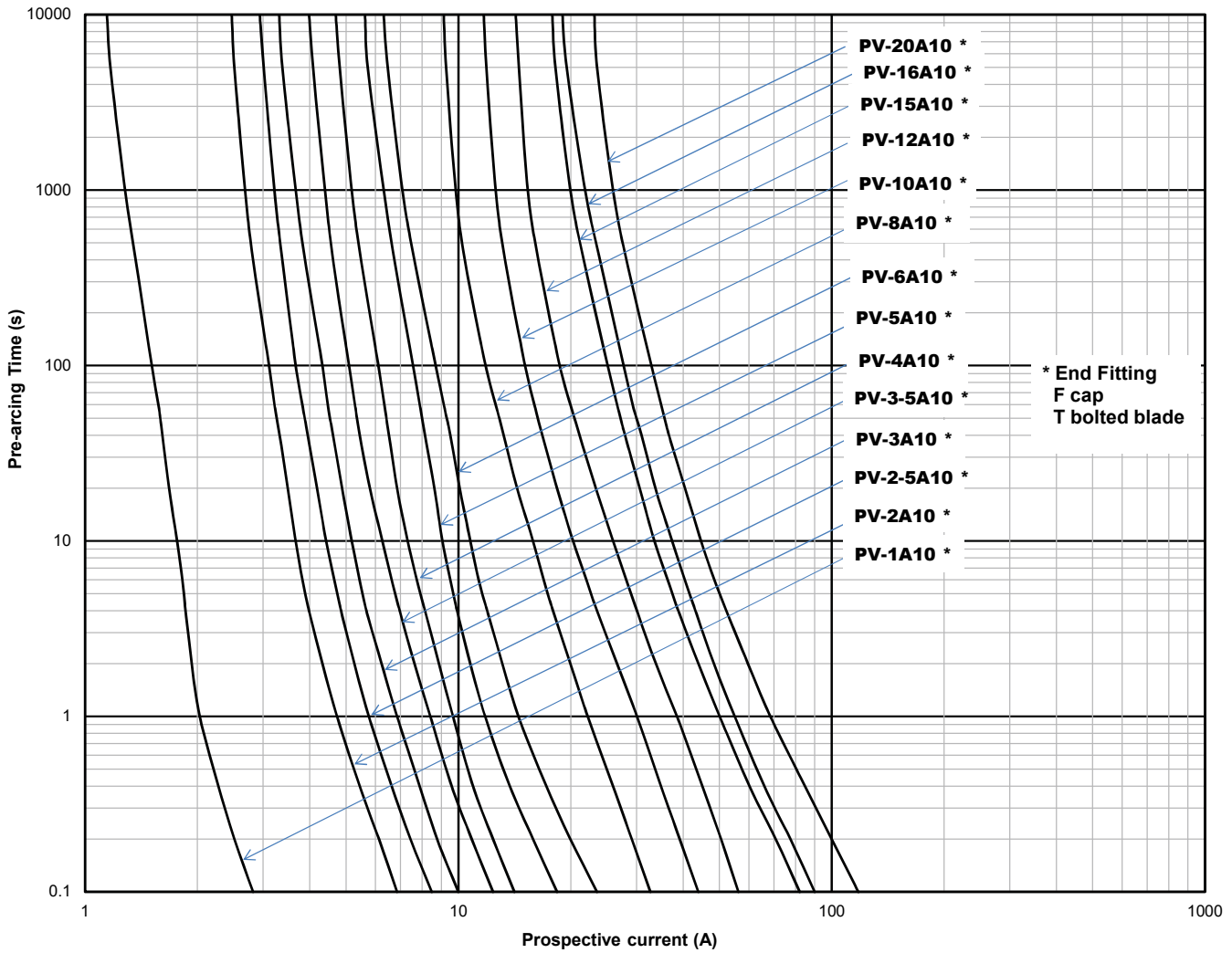

### Temperature deratings

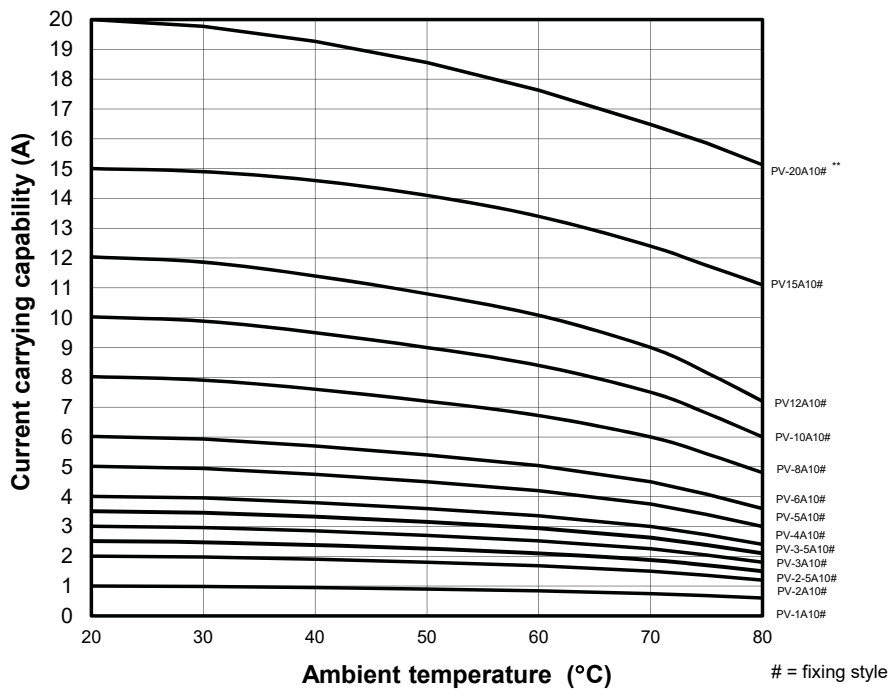

Data sheet: [720110](#)

CHPV Modular fuse holders for 10 x 38 mm fuse links - 1000 V d.c. (IEC/UL) - 32 A (IEC), 30 A (UL)

Specifications

Description

Compact DIN-Rail mounting fuse holders specifically designed for 10 x 38 mm photovoltaic fuse links.

Catalog numbers

- CHPV1U 1-pole modular fuse holder
- CHPV2U 2-pole modular fuse holder
- CHPV1IU 1-pole modular fuse holder with neon indicator
- CHPV2IU 2-pole modular fuse holder with neon indicator



Technical data

IEC		UL		Terminal rating	Rated breaking withstand capacity	Compatible Bussmann series fuse links
Rated voltage	Rated current	Rated voltage	Rated current			
1000 V d.c.	32 A	1000 V d.c.	30 A	IEC 1 to 25 mm <sup>2</sup> 70°C PVC Copper cable (solid stranded or fine stranded) Spade lug Comb bus bar	33 kA rms sym	Solar PV range: PVM, PV-A10F

Standards / Agency information

IEC	UL	CSA	CCC	CE
IEC 60269-1	UL 4248-1 UL4248-19 UL file E14853	C22.2 No 4248.1 C22.2 No 4248.19	GB 13539.1	DCB 272

Dimensions mm

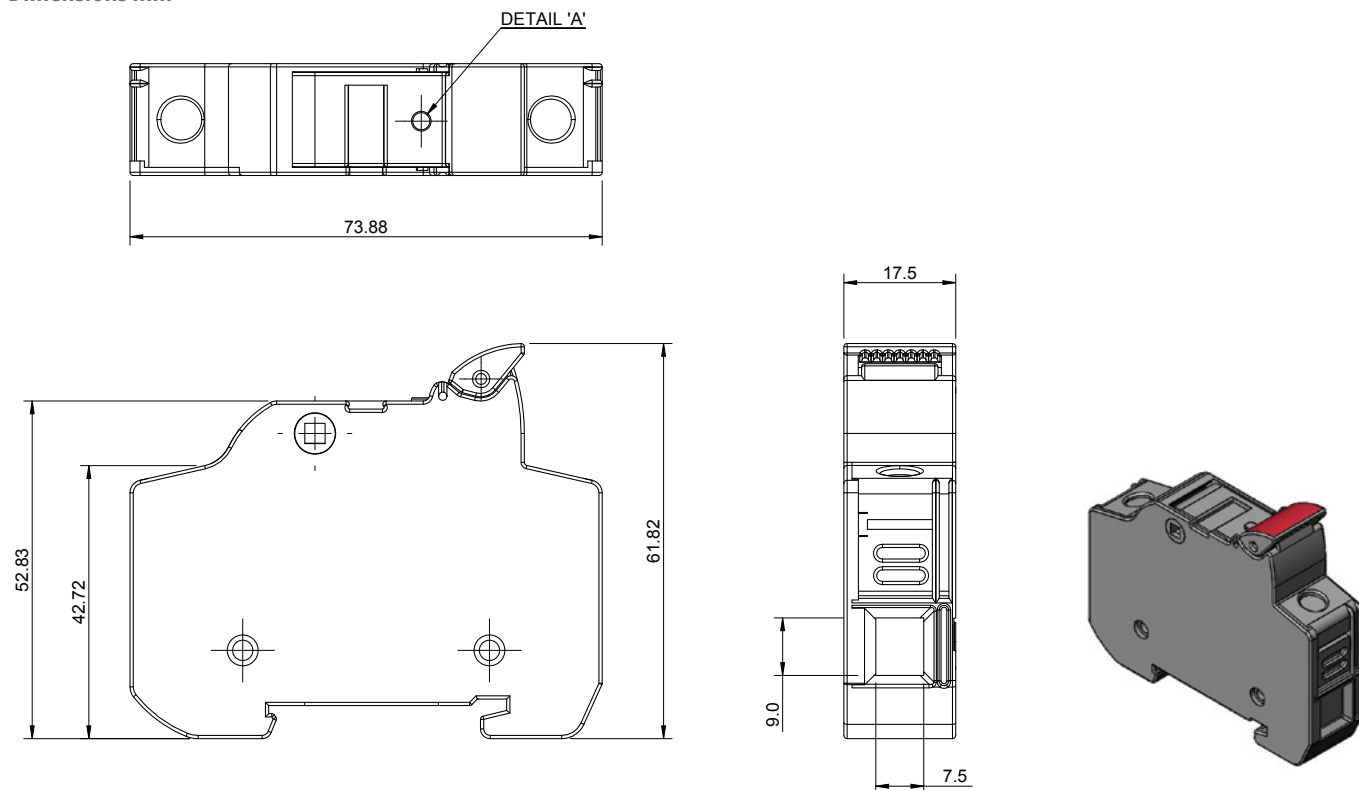

Data sheet: [720147](#)

# Photovoltaic fuse links, fuse bases and holders

## 1000 V d.c. (IEC/UL) - 32 A to 400 A - NH - PV-ANH

### Specifications

#### Description

A range of NH size bladed fuse links specifically designed for protecting and isolating photovoltaic array combiners and disconnects. These fuse links are capable of interrupting low overrated currents associated with faulted PV systems (reverse rated current, multi-array fault).

#### Technical data

- Rated voltage: 1000 V d.c. (IEC and UL)
- Rated current: 32 A to 400 A
- Breaking capacity: 50 kA
- Operating class: gPV and UL PV fuse links

#### Compatible fuse base

SD-D-PV see page 352

#### Standards / Agency information

IEC 60269-6, UL Recognised file 2579 E335324 for size 1 only, RoHS compliant



### Catalog numbers - Bladed version

Fuse link body size	Rated voltage	Rated current (Amps)	I <sup>2</sup> t (A <sup>2</sup> Sec)		Watts loss (W)		Catalog numbers	
			Pre-arcing	Total at 1000 V d.c.	0.8 I <sub>n</sub>	I <sub>n</sub>	Blade without bolt holes	Blade with bolt holes
NH1	1000 V d.c. (IEC/UL)	32	80	720	4	8	PV-32ANH1	PV-32ANH1-B
		40	185	1670	5	9	PV-40ANH1	PV-40ANH1-B
		50	400	3600	6	11	PV-50ANH1	PV-50ANH1-B
		63	470	4300	6	12	PV-63ANH1	
		80	640	5760	8	15	PV-80ANH1	
		100	1300	11,700	8	16	PV-100ANH1	
		110	2100	18,900	9	18.5	PV-110ANH1	
		125	2600	23,400	9	17	PV-125ANH1	
		160	5200	46,800	14	27	PV-160ANH1	
		175	8300	74,700	15	29	PV-175ANH1	
NH2	1000 V d.c. (IEC/UL)	200	10,200	8,2000	13	25	PV-200ANH1	
		160	4600	37,000	14	28	PV-160ANH2	
		200	9500	76,000	16	32	PV-200ANH2	
NH3	1000 V d.c. (IEC/UL)	250	17,000	136,000	19	38	PV-250ANH2	
		300	32,000	260,000	24	40	PV-300ANH3	
		315	32,000	260,000	26	44	PV-315ANH3	
		350	44,500	370,000	27	45	PV-350ANH3	
		355	44,500	370,000	28	46	PV-355ANH3	
		400	67,500	550,000	30	50	PV-400ANH3	

1000 V d.c. (IEC/UL) - 32 A to 400 A - NH - PV-ANH

Catalog numbers - Bolted version

Fuse link body size	Rated voltage	Rated current (Amps)	I <sup>2</sup> t (A <sup>2</sup> Sec)		Watts loss (W)		Catalog numbers	
			Pre-arcing	Total at 1000 V d.c.	0.8 I <sub>n</sub>	I <sub>n</sub>	Blade with bolt holes	Blade with bolt holes and lugs
NH1	1000 V d.c. (IEC/UL)	63	470	4300	6	12	PV-63ANH1-B	PV-63ANH1-BL
		80	640	5760	8	15	PV-80ANH1-B	PV-80ANH1-BL
		100	1300	11,700	8	16	PV-100ANH1-B	PV-100ANH1-BL
		125	2600	23,400	9	17	PV-125ANH1-B	PV-125ANH1-BL
		160	5200	46,800	14	27	PV-160ANH1-B	PV-160ANH1-BL
		200	10,200	82,000	13	25	PV-200ANH1-B	PV-200ANH1-BL
NH2	1000 V d.c. (IEC/UL)	160	4600	37,000	14	28	PV-160ANH2-B	PV-160ANH2-BL
		200	9500	76,000	16	32	PV-200ANH2-B	PV-200ANH2-BL
		250	17,000	136,000	19	38	PV-250ANH2-B	PV-250ANH2-BL
NH3	1000 V d.c. (IEC/UL)	315	32,000	260,000	26	44	PV-315ANH3-B	PV-315ANH3-BL
		355	38,000	310,000	29	48	PV-355ANH3-B	PV-355ANH3-BL
		400	61,000	490,000	32	50	PV-400ANH3-B	PV-400ANH3-BL

Dimensions (mm) - NH1, blade without bolt holes

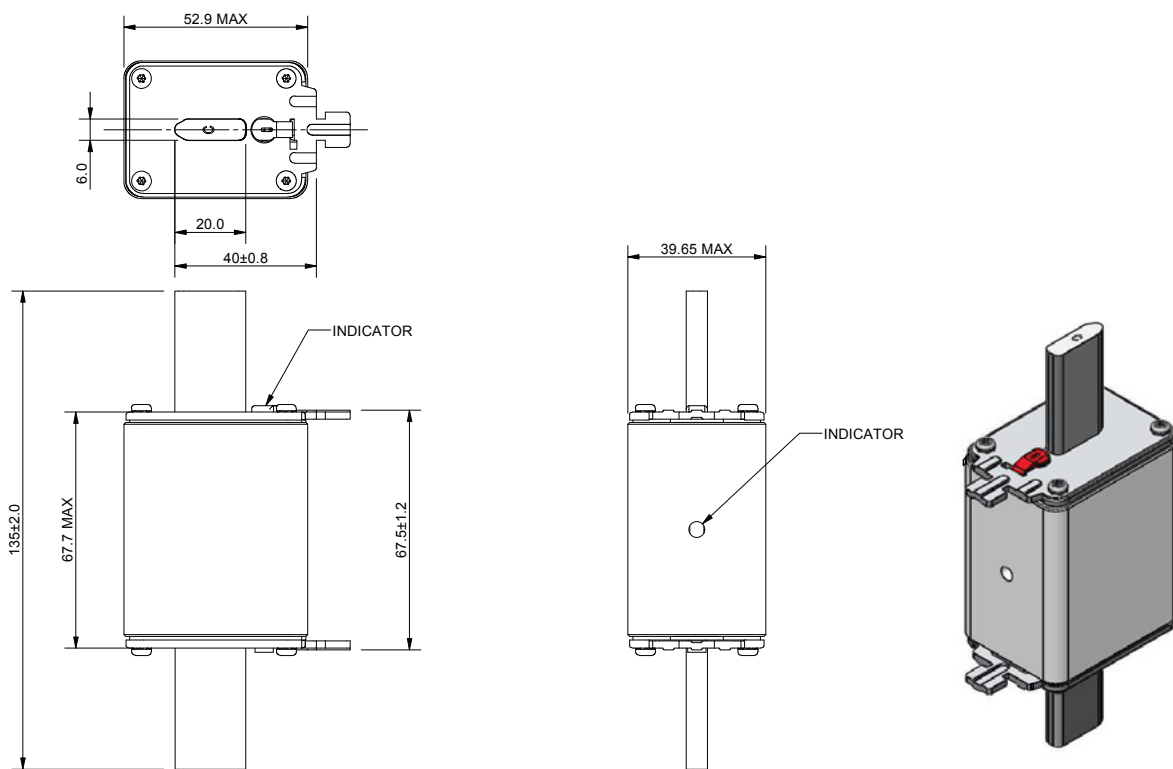

# Photovoltaic fuse links, fuse bases and holders

## 1000 V d.c. (IEC/UL) - 32 A to 400 A - NH - PV-ANH

### Dimensions (mm) - NH2, blade without bolt holes

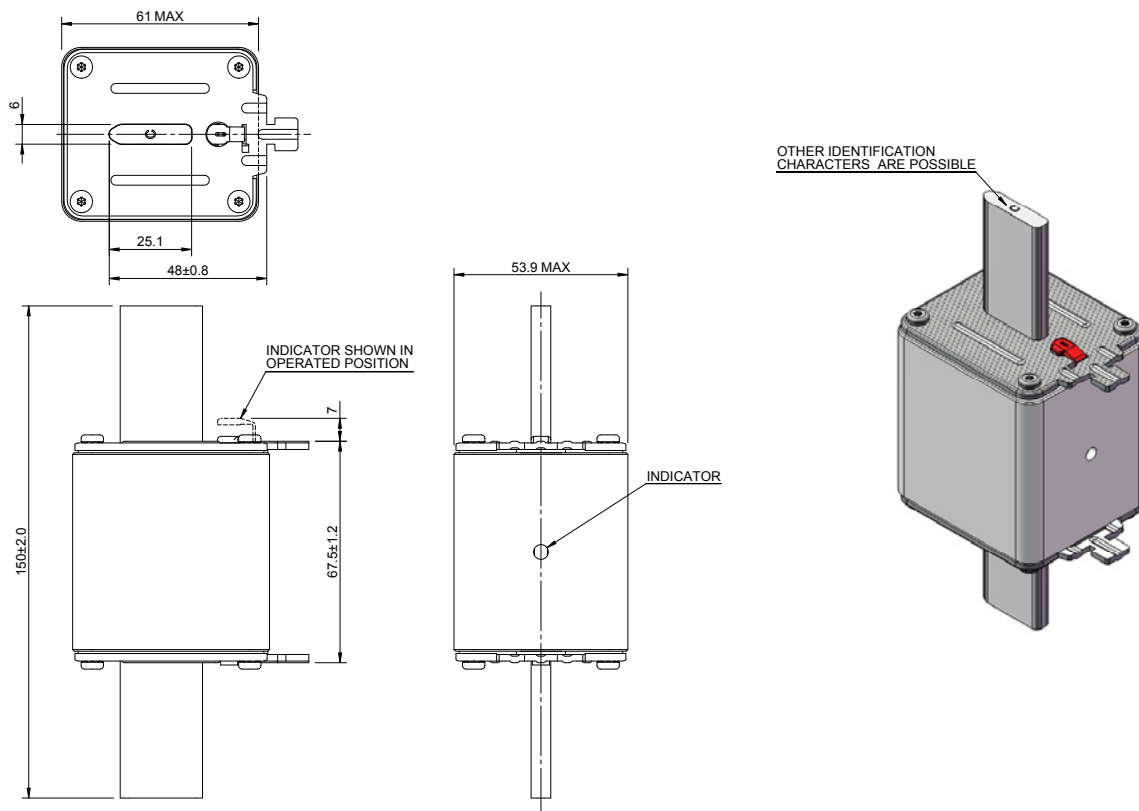

### Dimensions (mm) - NH3, blade without bolt holes

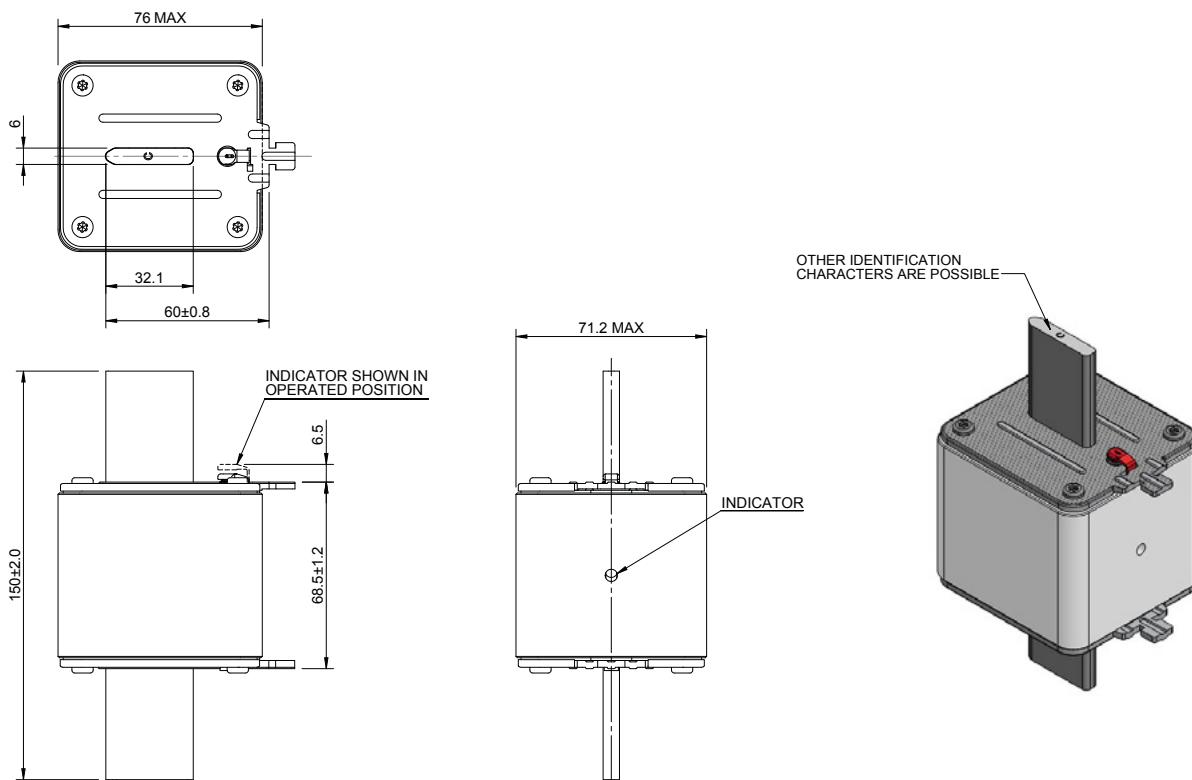

1000 V d.c. (IEC/UL) - 32 A to 400 A - NH - PV-ANH

Dimensions (mm) - NH1, blade with bolt holes

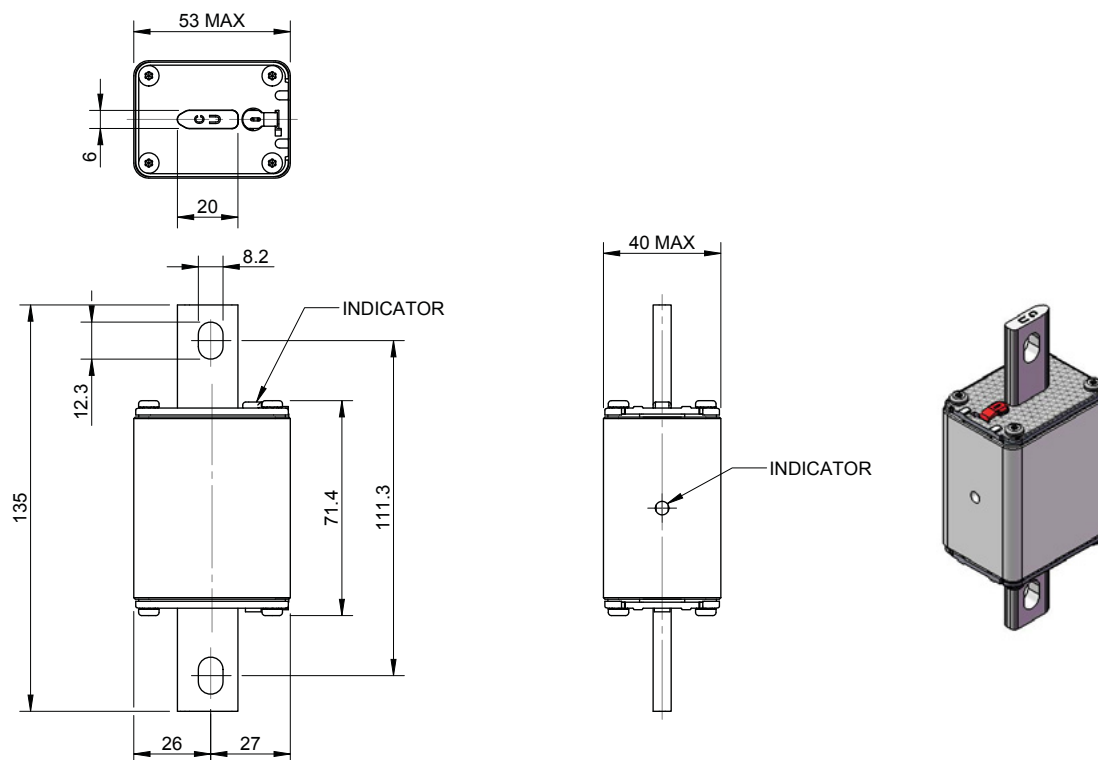

Dimensions (mm) - NH2, blade with bolt holes

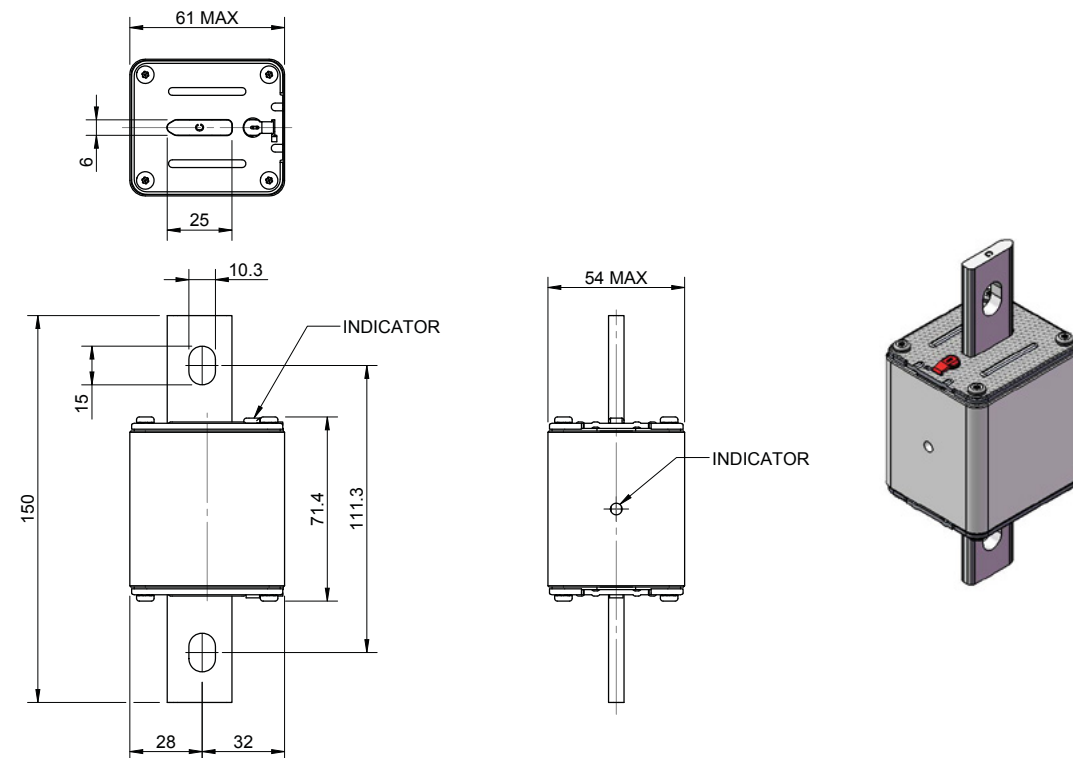

# Photovoltaic fuse links, fuse bases and holders

## 1000 V d.c. (IEC/UL) - 32 A to 400 A - NH - PV-ANH

Dimensions (mm) - NH3, blade with bolt holes

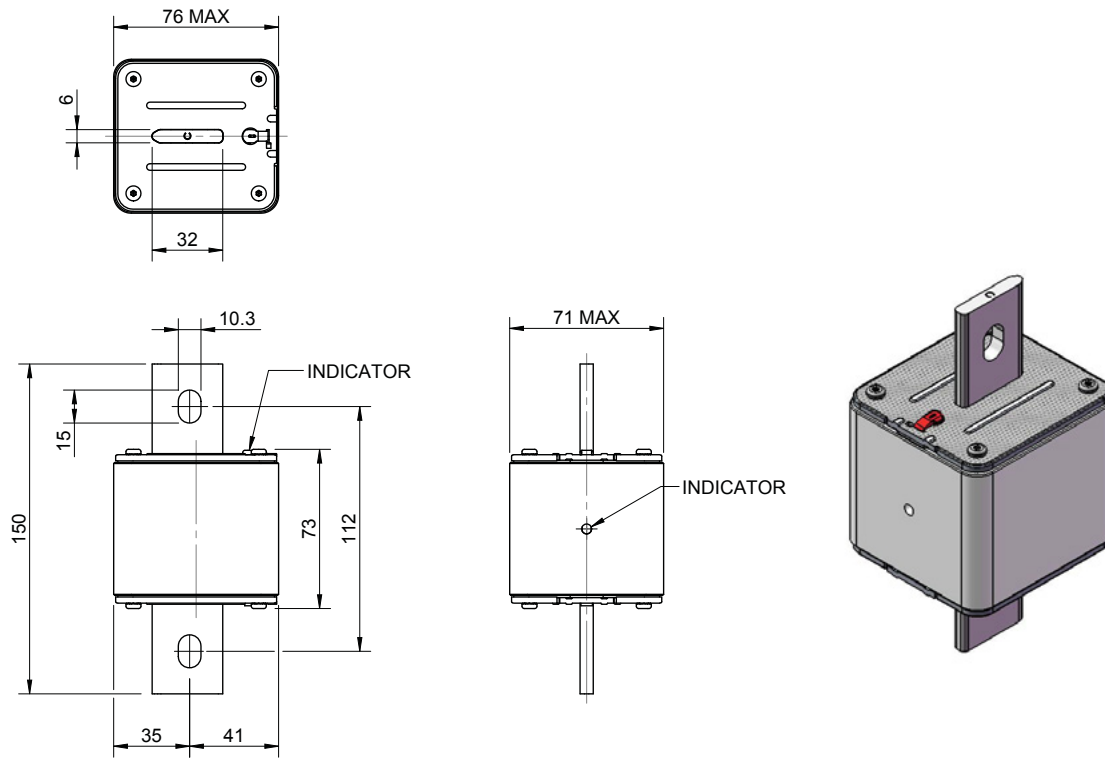

Dimensions (mm) - NH1, blade with bolt holes and lugs

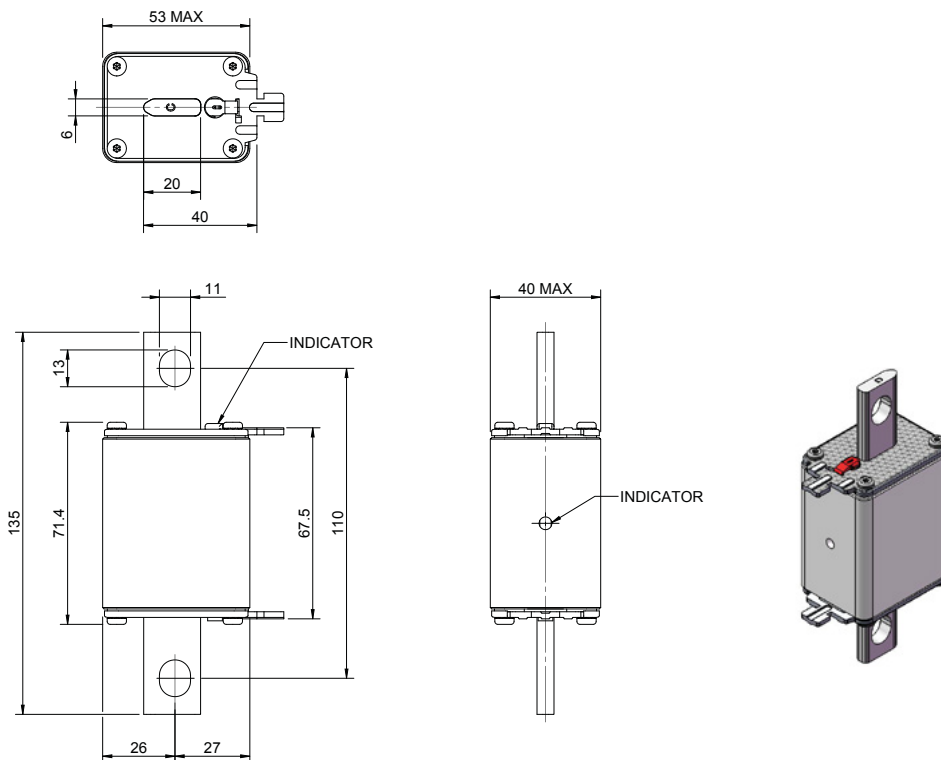

1000 V d.c. (IEC/UL) - 32 A to 400 A - NH - PV-ANH

Dimensions (mm) - NH2, blade with bolt holes and lugs

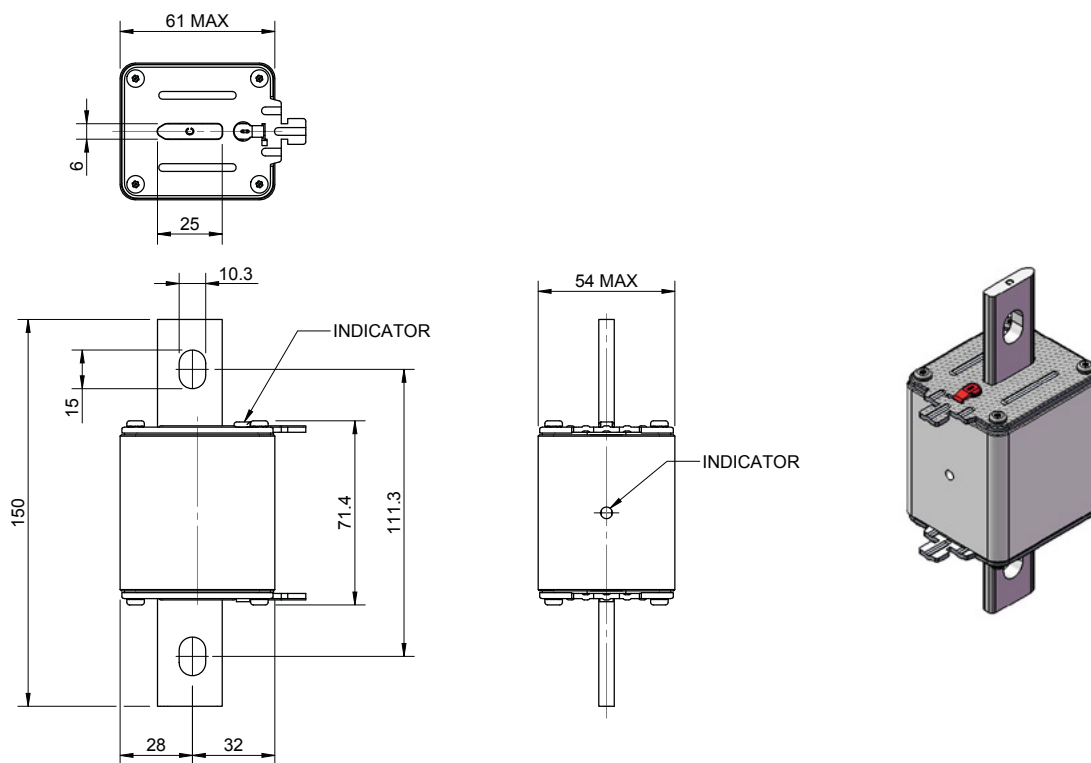

Dimensions (mm) - NH3, blade with bolt holes and lugs

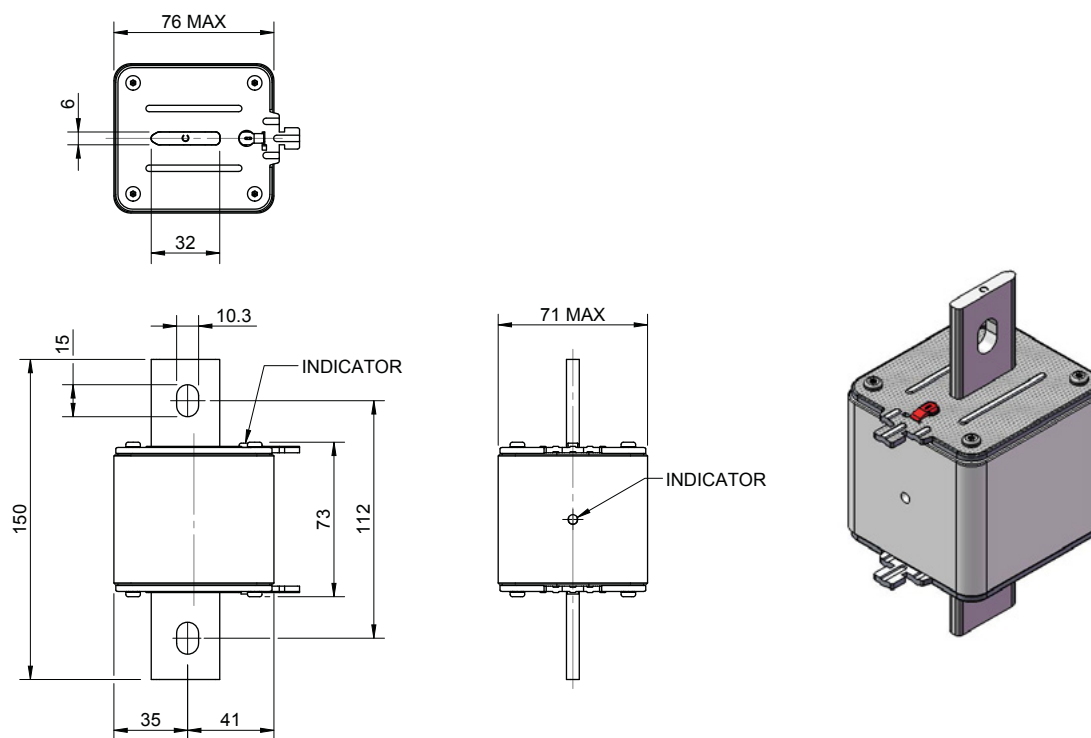

# Photovoltaic fuse links, fuse bases and holders

## 1000 V d.c. (IEC/UL) - 32 A to 400 A - NH - PV-ANH

Time-current curve - Size 1, 32 A to 200 A

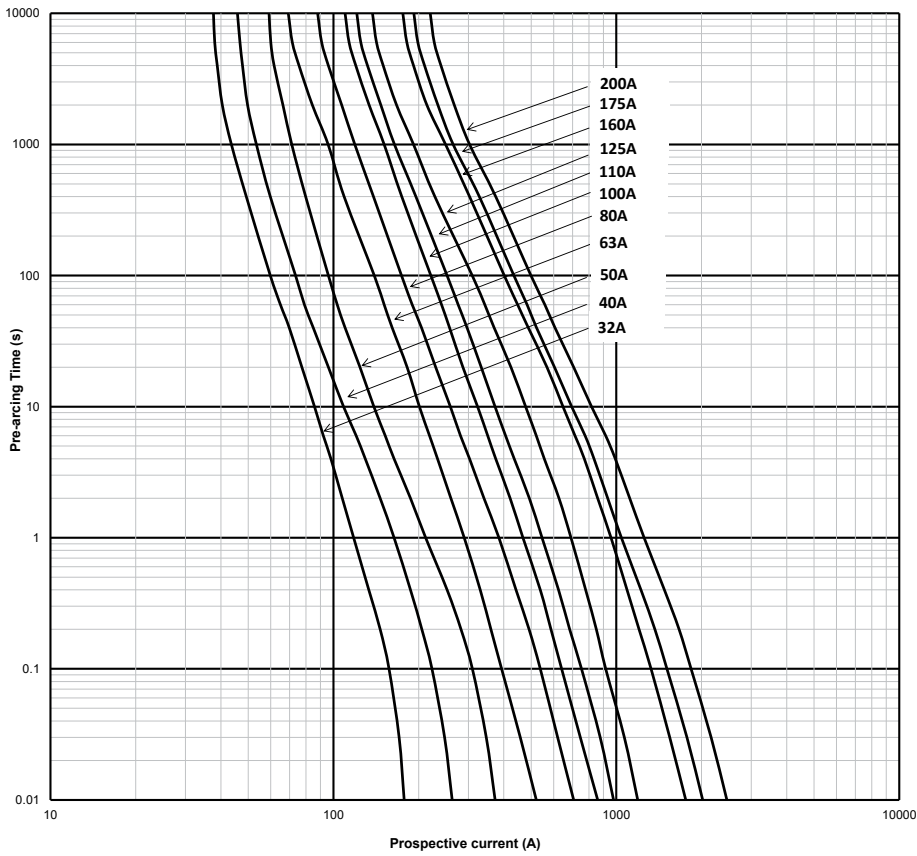

Time-current curve - Size 2, 160 A to 250 A

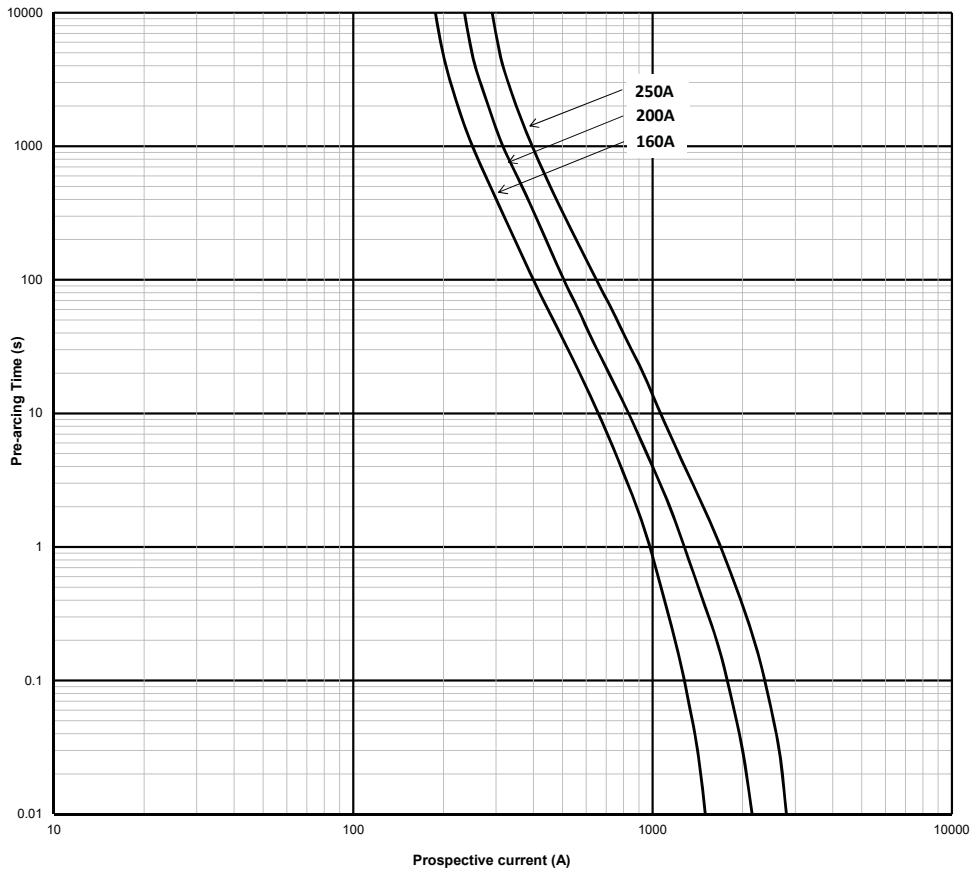

Data sheet: [720133](#)

1000 V d.c. (IEC/UL) - 32 A to 400 A - NH - PV-ANH

Time-current curve - Size 3, 300 A to 400 A

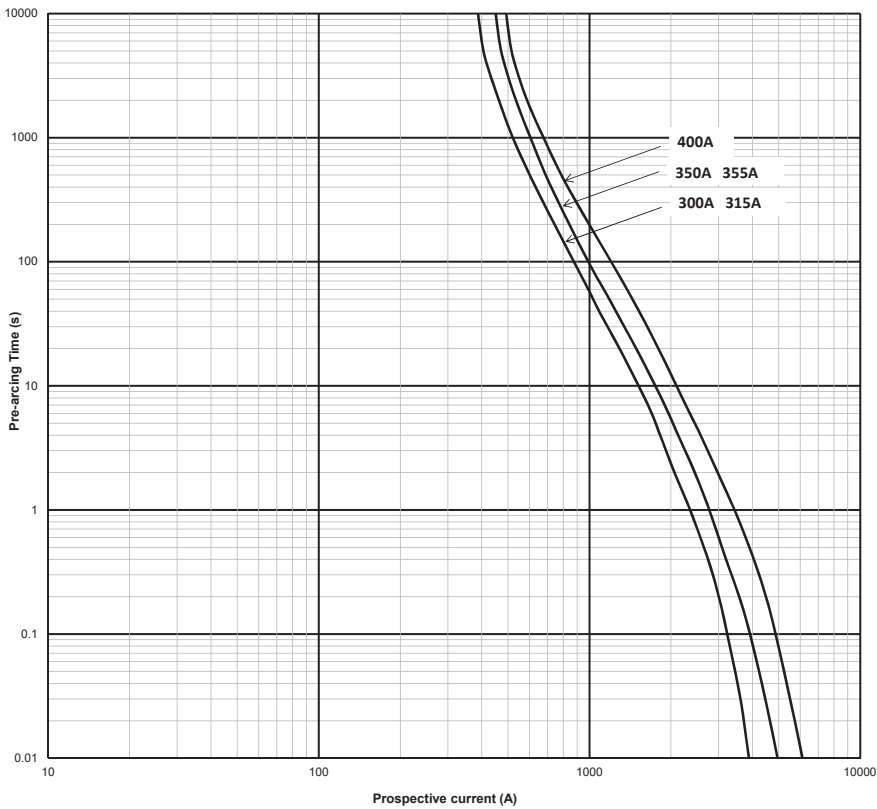

Temperature derating curve - Sizes 1 to 3

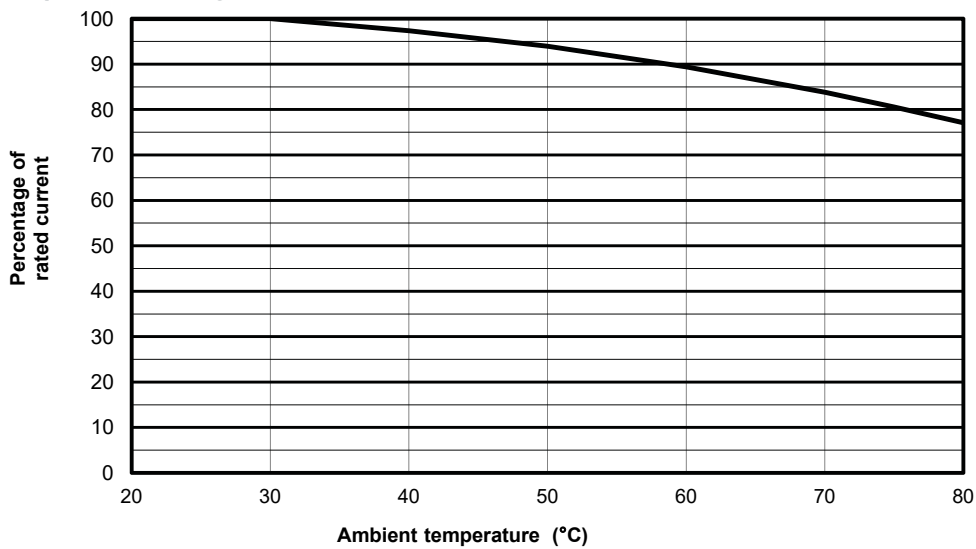

# Photovoltaic fuse links, fuse bases and holders

## SD-D-PV fuse base for NH fuse links - 1500 V d.c. (IEC) - 1000 V d.c. (UL/CSA) - 250 A to 630 A

### Specifications

#### Description

Sizes 1 to 3 NH Fuse bases specifically designed for use with Bussmann series range of NH PV (Photovoltaic) fuse links.

#### Technical data

- Rated voltage:
  - 1500 V d.c. (IEC)
  - 1000 V d.c. (UL/CSA)
- Rated current:
  - 250 A (SD1)
  - 400 A (SD2)
  - 630 A (SD3)
- Fuse base sizes: 1 to 3
- Withstand: 50 kA
- Power acceptance
  - SD1: 32 W
  - SD2: 45 W
  - SD3: 60 W



#### Standards / Agency information

IEC 60269-1, UL Listed - UL File #E348242, CSA file #47235

#### Accessories:

- Microswitches - 170H0236, 170H0238 and BVL50
- IP20 Finger-Safe Protection Kit - TD1-IP20, TD2-IP20, TD3-IP20
- Fuse extraction handle
- Shroud kits

#### Dimensions (mm) - 1-pole with phase barriers

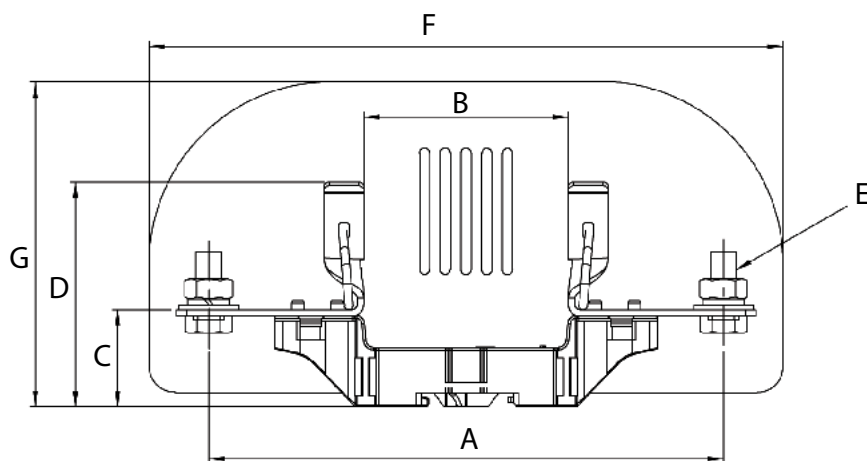

Catalog numbers	Poles/Type	A	B	C	D	E	F	G
SD1-D-PV	1-pole	175	79	37	78	M10x25	245	125.5
SD2-D-PV	1 pole	199	79	37.5	86	M10x25	245	125.5
SD3-D-PV	1-pole	209	82	37.5	88	M12x30	260	137.5

Data sheet: [720149](#)

**SD-D-PV fuse base for NH fuse links - 1500 V d.c. (IEC) - 1000 V d.c. (UL/CSA) - 250 A to 630 A**

Dimensions (mm) - 1-pole without phase barriers

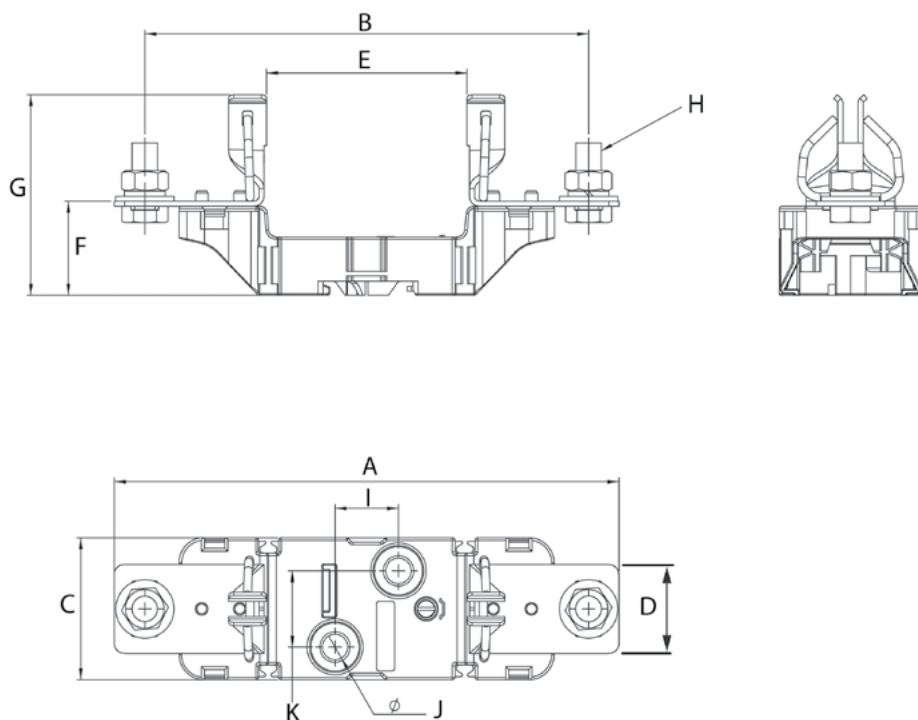

Catalog numbers	Poles	A	B	C	D	E	F	G	H	I	J	K
SD1-D-PV	1-pole	199	175	56	35	79	37	78	M10x25	25	10	30
SD2-D-PV	1 pole	224	199	56	35	79	37.5	86	M10x25	25	10	30
SD3-D-PV	1-pole	239	209	56	36	82	37.5	88	M12x30	25	10	30

# Photovoltaic fuse links, fuse bases and holders

## 1000 V d.c. (IEC/UL) - 160 A to 400 A - PV-AF - Flush end

### Specifications

#### Description

A range of flush end fuse links specifically designed for protecting and isolating photovoltaic array combiners and disconnects. These fuse links are capable of interrupting low overrated currents associated with faulted PV systems (reverse rated current, multi-array fault).

#### Technical data

- Rated voltage: 1000 V d.c. (IEC and UL)
- Rated current: 160 A to 400 A
- Breaking capacity: 50 kA
- Operating class: gPV and UL PV fuse links

#### Standards / Agency information

IEC 60269-6, UL 2579 (file number E335324), CSA Listed, RoHS compliant



### Catalog numbers

Fuse link type	Fuse link body size	Rated voltage	Rated current (Amps)	I <sup>2</sup> t (A <sup>2</sup> Sec)		Watts loss (W)		Catalog numbers
				Pre-arcing	Total at 1000 V d.c.	0.8 I <sub>n</sub>	I <sub>n</sub>	
Flush end	2	1000 V d.c.(IEC/UL)	160	4600	37,000	15	30	PV-160AF2
			200	9500	76,000	17	34	PV-200AF2
			250	17,000	136,000	19	38	PV-250AF2
	3	1000 V d.c.(IEC/UL)	315	27,000	240,000	30	49	PV-315AF3
			355	37,000	350,000	31	51	PV-355AF3
			400	61,500	550,000	32	52	PV-400AF3

### Dimensions (mm) - Size 2

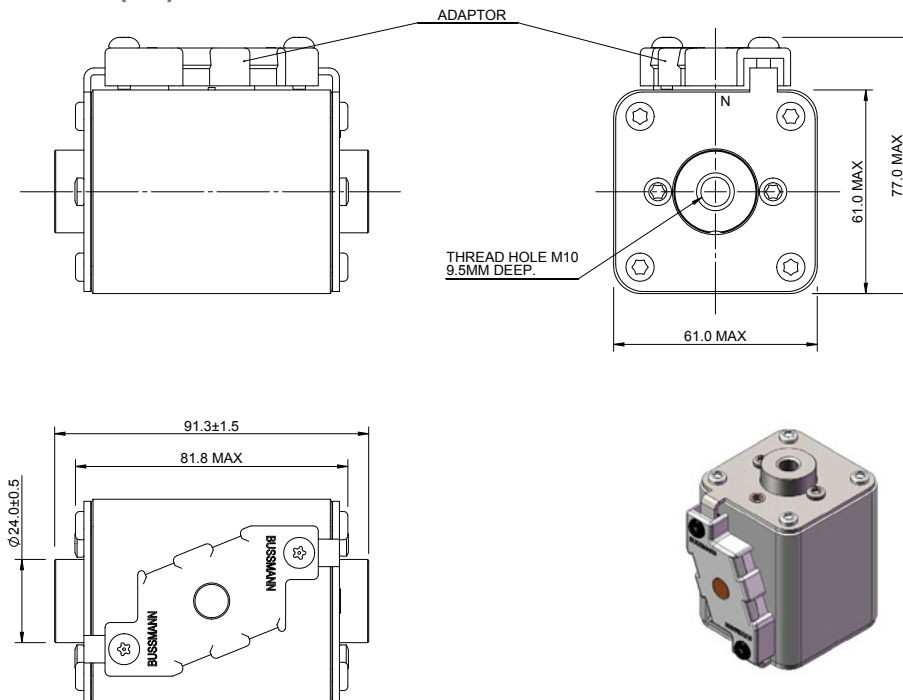

Data sheet: [10370](#)

1000 V d.c. (IEC/UL) - 160 A to 400 A - PV-AF - Flush end

Dimensions (mm) - Size 3

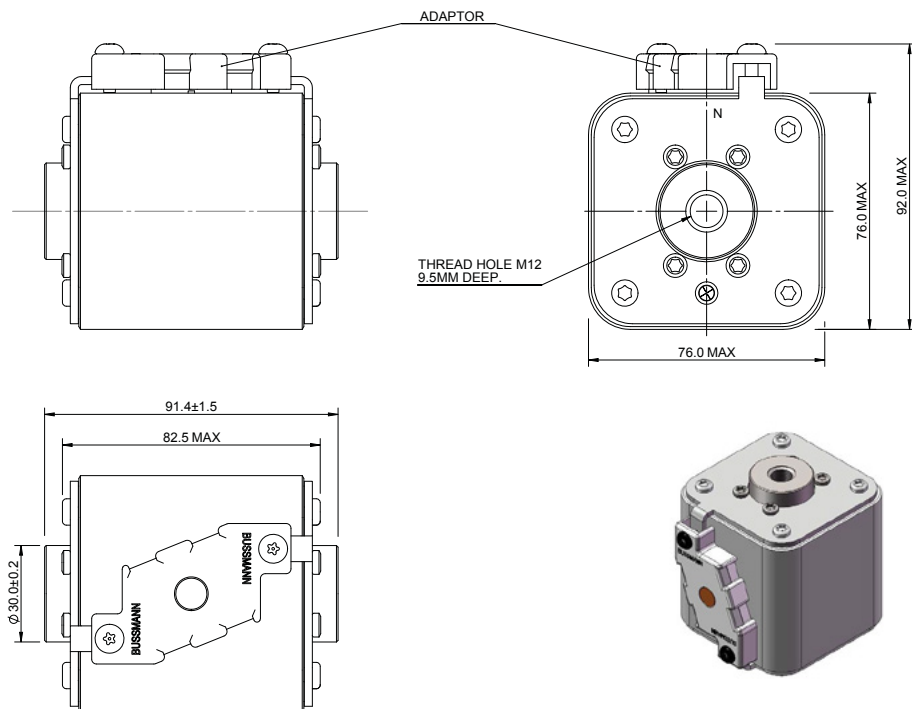

Time-current curve - Size 2, 160 A to 250 A

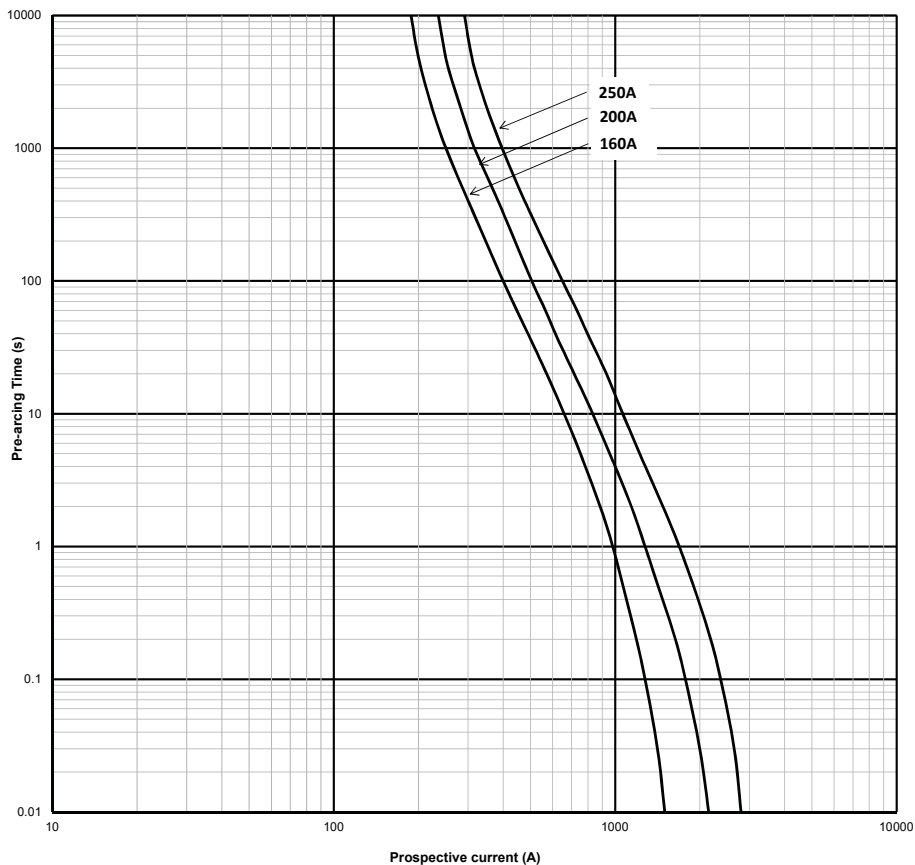

Data sheet: [10370](#)

# Photovoltaic fuse links, fuse bases and holders

## 1000 V d.c. (IEC/UL) - 160 A to 400 A - PV-AF - Flush end

### Time-current curve -Size 3, 315 A to 400 A

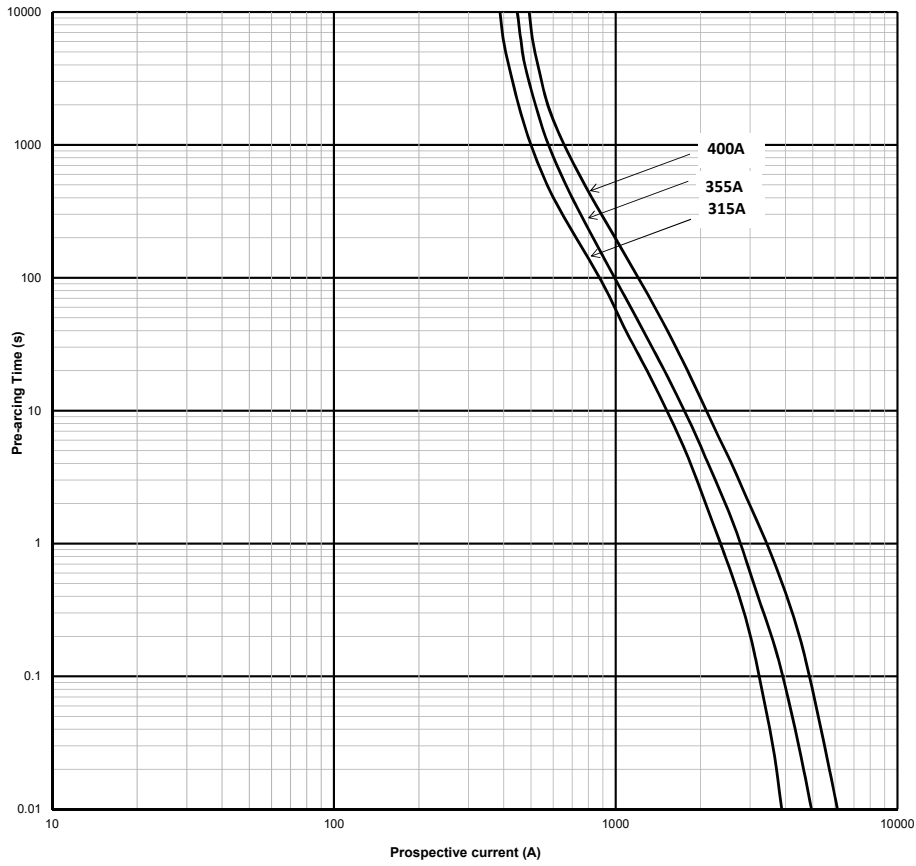

1000 and 1100 V d.c. (IEC/UL) - 15 A to 32 A - PV-14F - 14 x 51 mm

Specifications

Description

A range of fuse links in a 14 x 51 mm package specifically designed for the protection and isolation of photovoltaic strings. The fuse links are capable of interrupting low overrated currents associated with faulted PV (reverse rated current, multi-array fault).

Technical data

- Rated voltage:
  - 1100 V d.c. (IEC and UL, 15 A and 20 A)
  - 1000 V d.c. (IEC and UL, 25 A and 32 A)
- Rated current: 15 A to 32 A
- Breaking capacity: 30 kA
- Operating class: gPV and UL PV fuse links

Compatible fuse holder

- CHPV14

Standards / Agency information

IIEC 60269-6, UL Recognised 2579 (File number E335324), RoHS compliant. Pending: CCC

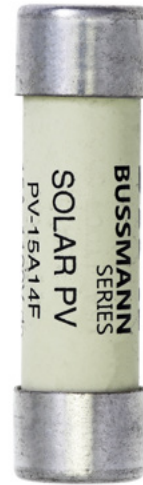

Catalog numbers

Rated voltage	Rated current (Amps)	I <sup>2</sup> t (A <sup>2</sup> Sec)		Watts loss (W)		Catalog numbers
		Pre-arcing	Total at rated voltage	0.8 I <sub>n</sub>	I <sub>n</sub>	
1100 V d.c. (IEC/UL)	15	14	270	2.1	4	PV-15A14F
	20	27	570	2.9	5.5	PV-20A14F
1000 V d.c. (IEC/UL)	25	65	950	2.8	5.3	PV-25A14F
	32	120	1750	4	7.5	PV-32A14F

Dimensions (mm)

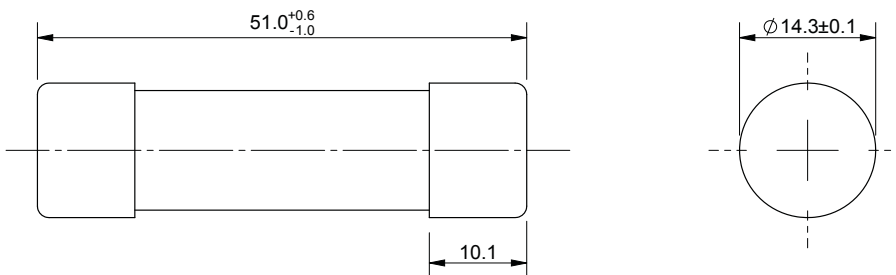

# Photovoltaic fuse links, fuse bases and holders

## 1000 and 1100 V d.c. (IEC/UL) - 15 A to 32 A - PV-14F - 14 x 51 mm

Time-current curve - 15 A to 32 A

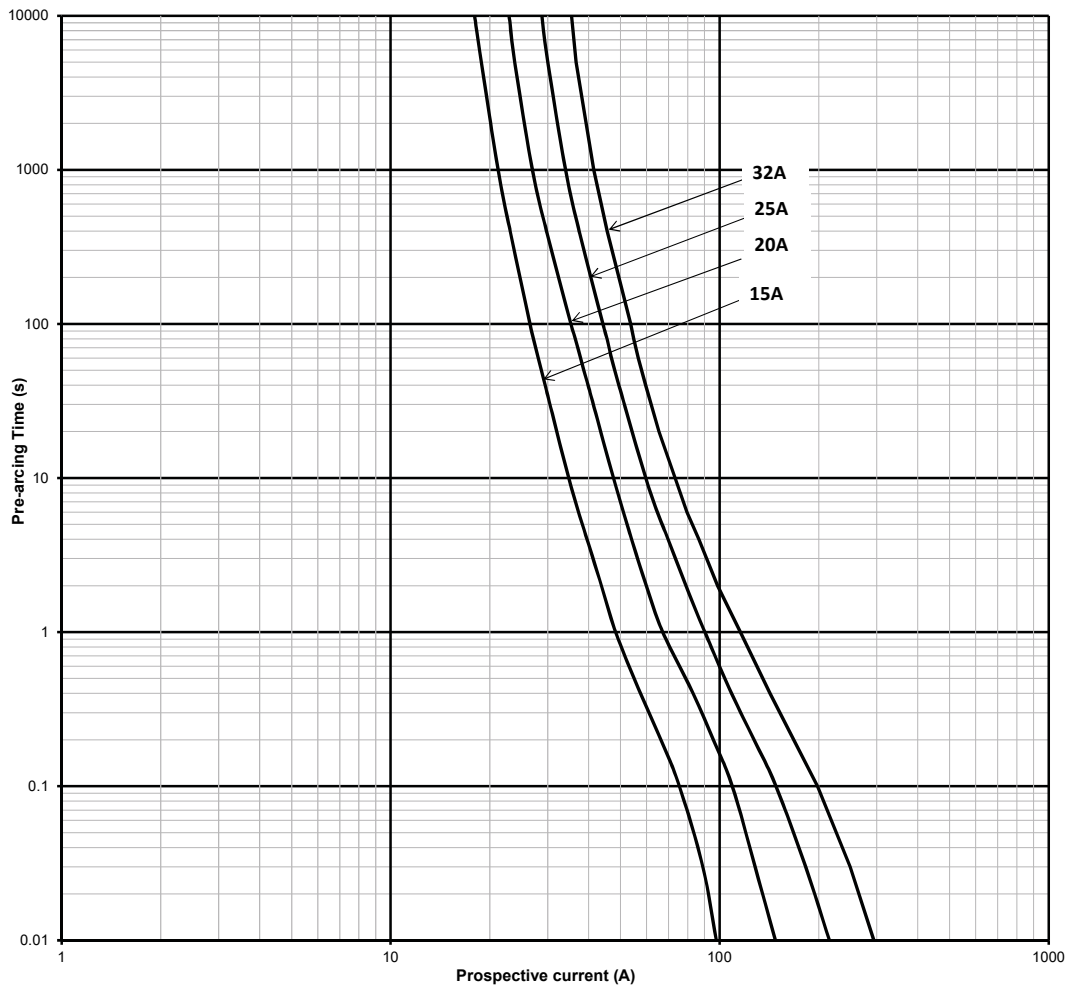

## CHPV14 Modular fuse holder for 14 x 51 mm fuse links - 1500 V d.c. - 50 A

### Specifications

#### Description

Compact DIN-Rail mounting fuse holders specifically designed for 14 x 51 mm photovoltaic fuse links.

#### Catalog numbers

- CHPV141U 1-pole without indicator
- CHPV142 2-pole without indicator
- CHPV141IU 1-pole with indicator
- CHPV142IU 2-pole with indicator

#### Standards / Agency information

IEC 60269-1 and 2, UL Listed file number E348242



### Technical data

Rated voltage	Rated current	Agency markings	Terminal rating	Rated breaking withstand capacity	Compatible Bussmann series fuse links
1500 V d.c.	32 A	IEC 60269-1 and 2  UL Listed file number E348242	Cable size: 1.5-50 mm <sup>2</sup>  Recommended torque setting: 3.5 Nm Maximum torque setting: 3.5Nm  Mounting 35 mm DIN-Rail or 2 x M4 panel mounting screws	10 kA d.c.	PV-A14F

### Accessories

Catalog numbers	Description	Unit packing
JV-L	Multi-pole connector kit. One kit will gang up to 4-poles together	12
CH14-CTP	IP20 Protection accessory, provides IP20 protection to terminals with 10mm <sup>2</sup> or less cable	12

### Dimensions (mm)

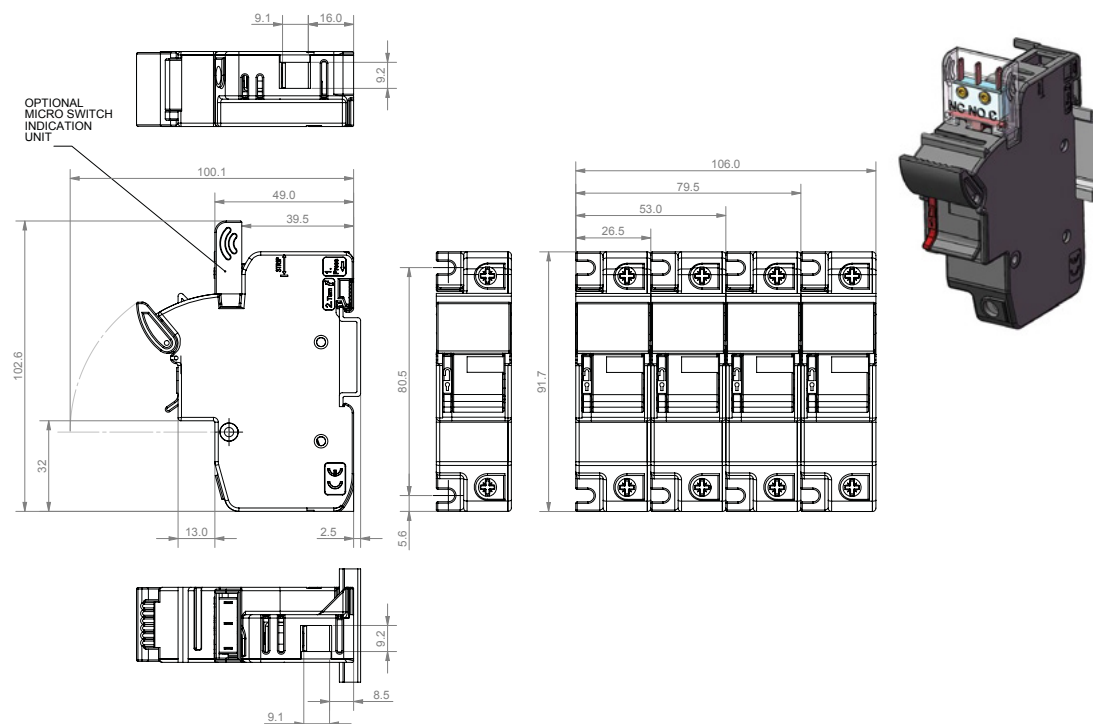

Data sheet: [10080](#)

# Photovoltaic fuse links, fuse bases and holders

## 1500 V d.c. (IEC/UL) - 2.25 A to 30 A - PV-A10F85L - 10 x 85 mm

### Specifications

#### Description

A range of fuse links in a 10 x 85 mm package specifically designed for the protection and isolation of photovoltaic strings.

#### Technical data

- Rated voltage: 1500 V d.c.
- Rated current: 2.25 A to 30 A
- Breaking capacity: 30 kA 1 ms
- Operating class: gPV
- Fuse body material
  - 2.25 A to 5 A: Ceramic
  - 12 A to 30 A: Melamine

#### Compatible fuse holder

CHPV15L85

#### Standards / Agency information

IEC 60269-6, UL 248-19, RoHS compliant

#### Catalog numbers



Ceramic fuse body



Melamine fuse body

Rated voltage	Rated current (Amps)	I <sup>2</sup> t (A <sup>2</sup> Sec)		Watts loss (W)		Catalog numbers
		Pre-arcing	Total at 1500 V d.c.	0.8 I <sub>n</sub>	I <sub>n</sub>	
1500 V d.c. (IEC/UL)	2.25	3	10	1.4	2.4	PV-2-25A10F85L
	2.5	4	10	1.3	2.1	PV-2.5A10F85L
	3	7	20	1.3	2.2	PV-3A10F85L
	3.5	10	20	1.6	2.6	PV-3.5A10F85L
	4	15	30	1.7	2.8	PV-4A10F85L
	5	33	60	1.7	2.8	PV-5A10F85L
	12	19	240	2.1	3.5	PV-12A10F85L
	15	42	300	2.2	3.6	PV-15A10F85L
	16	48	350	2.1	3.5	PV-16A10F85L
	20	108	800	2.7	4.5	PV-20A10F85L
	25	190	1400	3.4	5.6	PV-25A10F85L
	30	485	3500	4	6.6	PV-30A10F85L

#### Dimensions (mm) - 2.25 A to 5 A (Ceramic fuse body)

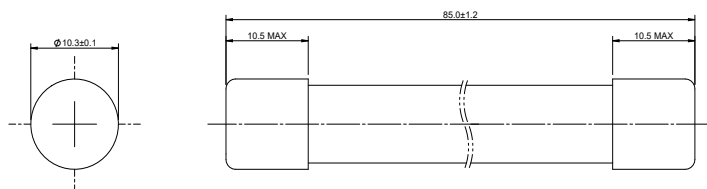

#### Dimensions (mm) - 12 A to 30 A (Melamine fuse body)

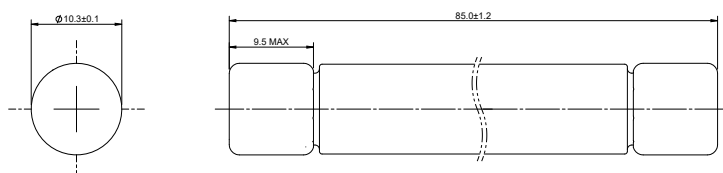

Data sheet: [10658](#)

1500 V d.c. (IEC/UL) - 2.25 A to 30 A - PV-A10F85L - 10 x 85 mm

Time-current curve - 2.25 A to 30 A

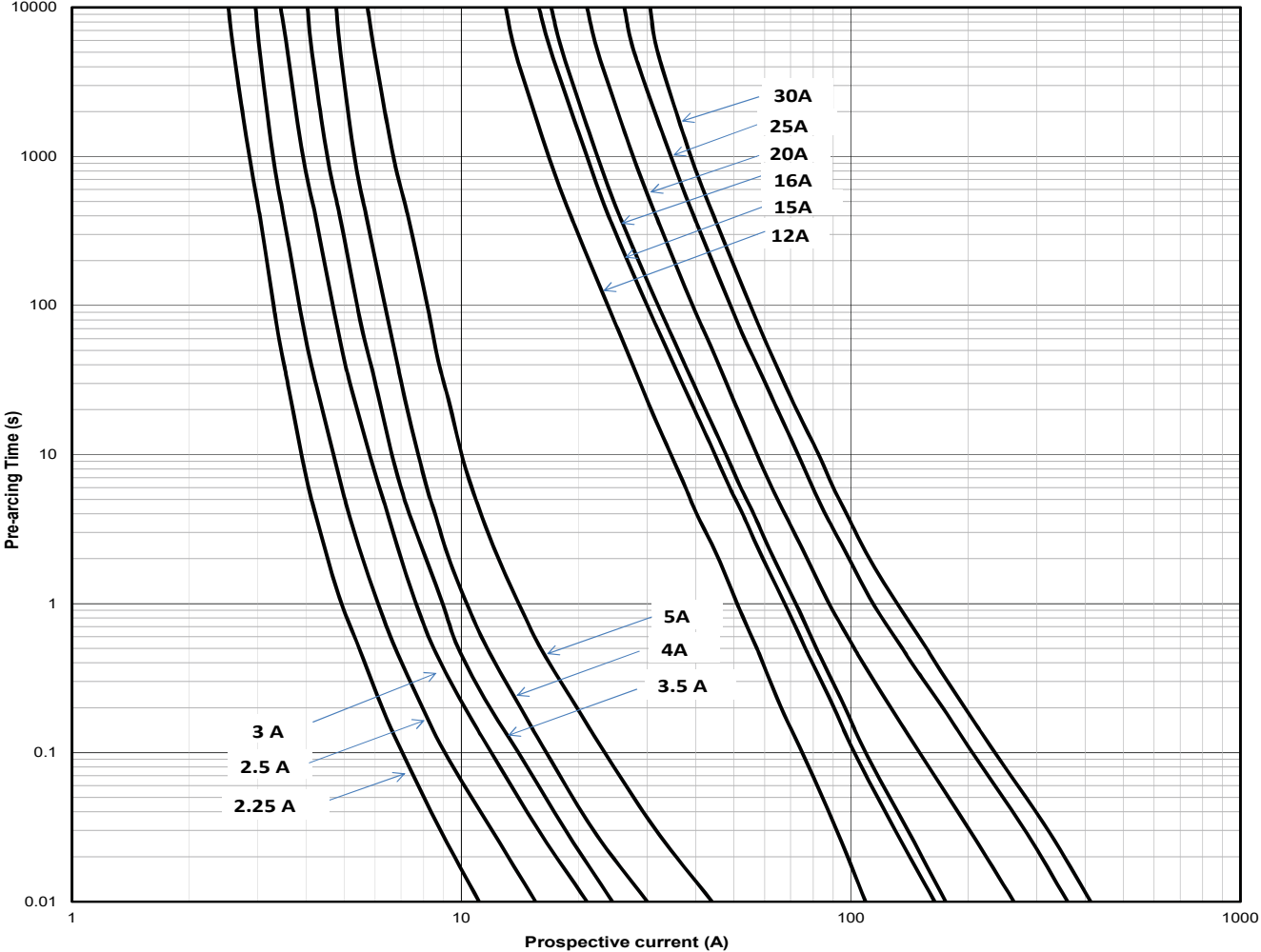

# Photovoltaic fuse links, fuse bases and holders

## CHPV15H85 fuse holder for 10 x 85 mm fuse links - 1500 V d.c. - 32 A (IEC/UL)

### Specifications

#### Description

Eaton's Bussmann series 10 x 85 mm fuse holders are suitable for use with 10 x 85 mm and 14 x 85 mm cylindrical gPV fuse links. The unique design offers high degree of safety. There is no possibility of any accidental contact with live parts during replacement of the fuse links. When the fuse carrier is extracted, a spring loaded cover moves out covering the live parts hence protecting against accidental damage.

#### Catalog symbol

CHPV15H85

#### Compatible fuse links

- 10 x 85 mm fuse links - PV-A10F85L
- 14 x 85 mm fuse links - PV-A14LF

#### Technical data

- Rated voltage: 1500 V d.c.
- Rated current: 32 A (IEC/UL)
- Breaking capacity: 50 kA

#### Standards / Agency information

- IIEC 60269-1
- IEC 60269-6
- UL 4248-1 Edition 1 (File number 348242)
- UL 4248-19 Edition 1



#### Dimensions (mm)

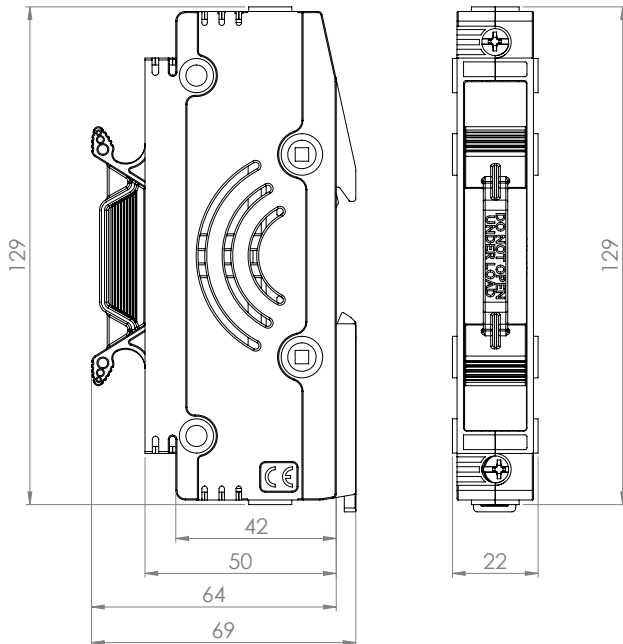

Data sheet: [ID135010](#)

## 1300-1500 V d.c. (IEC and UL) - 2.25 A to 32 A - PV-14L - 14 x 65 mm

### Specifications

#### Description

A range of fuse links in a 14 x 65 mm package specifically designed for the protection and isolation of photovoltaic strings. The fuse links are capable of interrupting low overrated currents associated with faulted PV (reverse rated current, multi-array fault).

#### Technical data

- Rated voltage:
  - 1500 V d.c. (IEC and UL, 2.25 A to 20 A)
  - 1300 V d.c. (IEC and UL, 25 A and 32 A)
- Rated current: 2.25 A to 32 A
- Breaking capacity: 10 kA
- Operating class: gPV and UL PV fuse links

#### Compatible fuse holder for PV-A14LF10F

CHPV15L85

#### Standards / Agency information

IEC 60269-6, UL Recognised 2579 (File number E335324), RoHS compliant, Pending: CCC.



### Catalog numbers

Rated voltage	Rated current (Amps)	I <sup>2</sup> t (A <sup>2</sup> Sec)		Watts loss (W)		Catalog numbers		
		Pre-arcing	Total at rated voltage	0.8 I <sub>n</sub>	I <sub>n</sub>	Cylindrical	Cylindrical with tags	Cylindrical with 10mm fixings
1500 V d.c. (IEC/UL)	2.25	4	8	1.4	2.3	PV-2.25A14LF	N/A	PV-2.25A14LF10F
	2.5	5	10	1.5	2.5	PV-2.5A14LF	PV-2.5A14L-T	PV-2.5A14LF10F
	3	8	14	1.7	2.8	PV-3A14LF	PV-3A14L-T	PV-3A14LF10F
	3.5	12	23	1.8	3.0	N/A	N/A	PV-3.5A14LF10F
	4	18	34	2	3.3	PV-4A14LF	PV-4A14L-T	PV-4A14LF10F
	15	16	190	2.9	5.1	PV-15A14LF	PV-15A14L-T	PV-15A14LF10F
1300 V d.c. (IEC/UL)	20	34	400	3.8	6.9	PV-20A14LF	PV-20A14L-T	PV-20A14LF10F
	25	65	550	4.1	7.5	PV-25A14LF	PV-25A14L-T	PV-25A14LF10F
	32	105	900	5.7	10.4	PV-32A14LF	PV-32A14L-T	PV-32A14LF10F

# Photovoltaic fuse links, fuse bases and holders

## 1300-1500 V d.c. (IEC and UL) - 2.25 A to 32 A - PV-14L - 14 x 65 mm

### Dimensions (mm) - PV-\*A14LF, Cylindrical

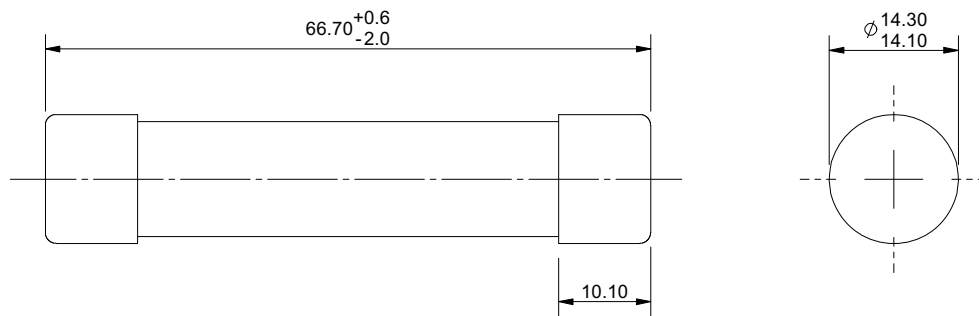

### Dimensions (mm) - PV-\*A14LF10F, Cylindrical with 10 mm Fixings

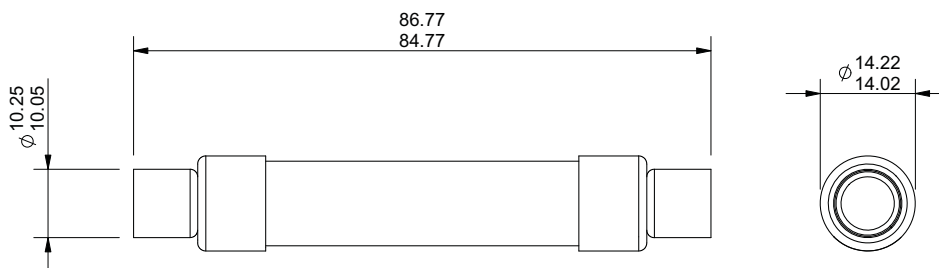

### Dimensions (mm) - PV-\*A14L-T, Cylindrical with tags

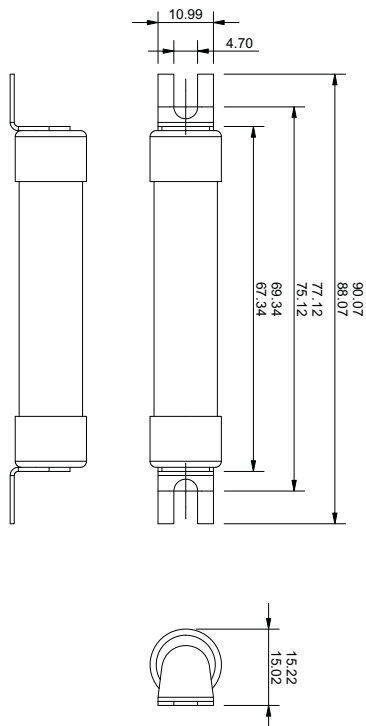

1300-1500 V d.c. (IEC and UL) - 2.25 A to 32 A - PV-14L - 14 x 65 mm

Time-current curve - 2.25 A to 4 A

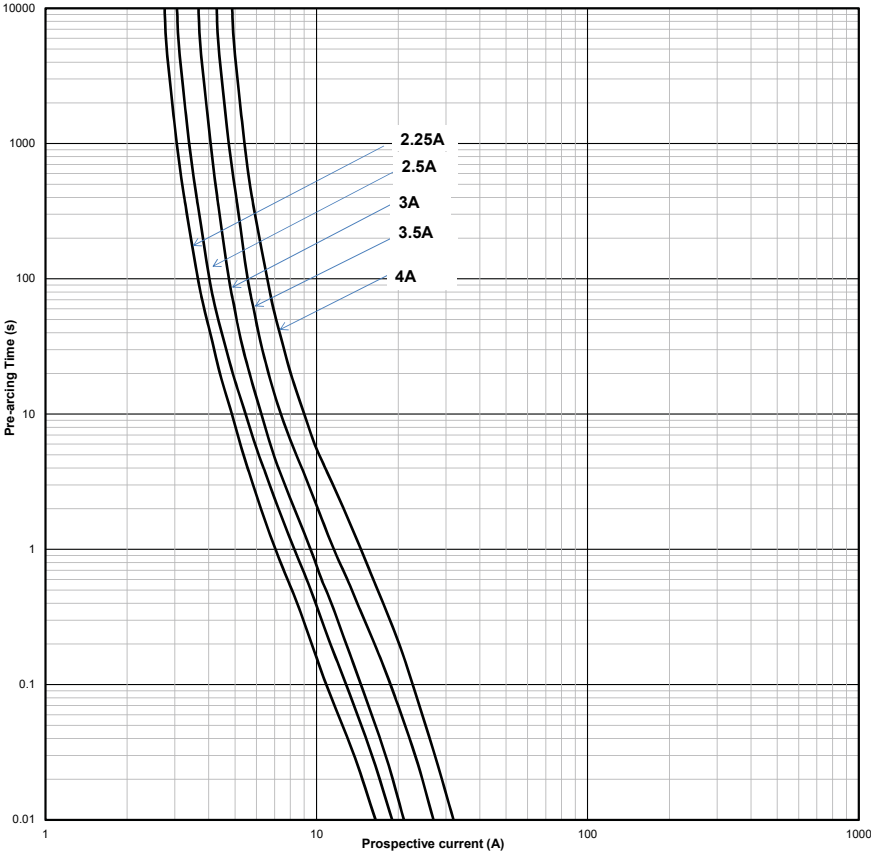

Time-current curve - 15 A to 32 A

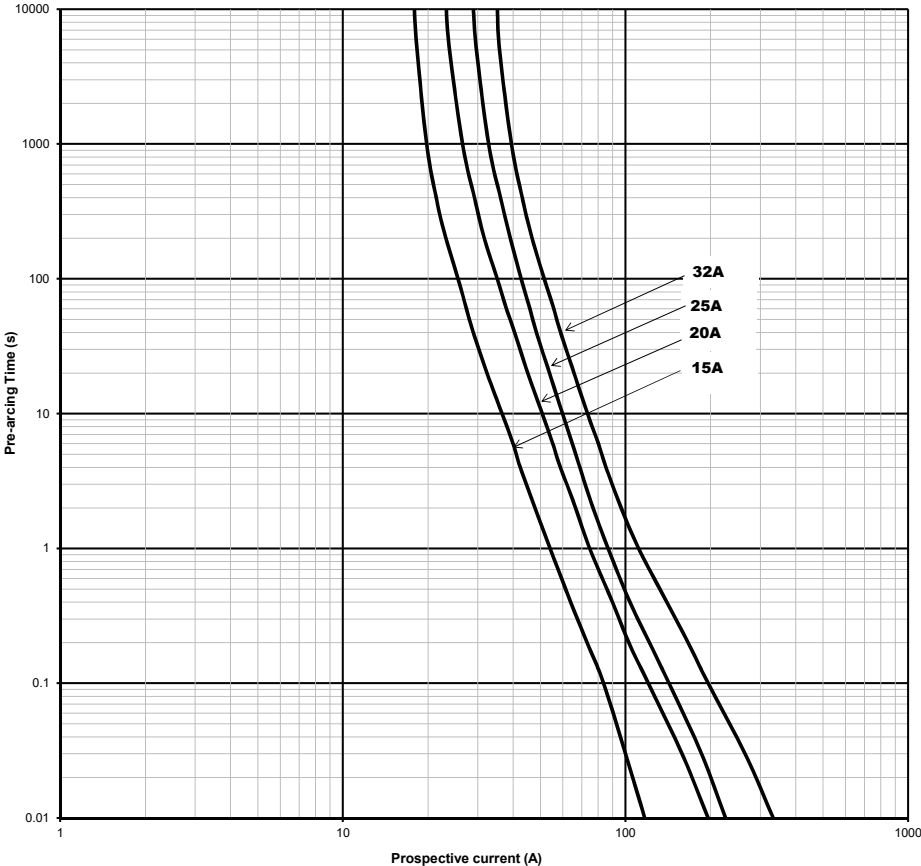

Data sheet: [10080](#)

# Photovoltaic fuse links, fuse bases and holders

## 1000-1500 V d.c. (IEC/UL) - 50 A to 600 A - PV-XL and PVS-3L - XL and 3L Style

### Specifications

#### Description

A range of XL package bladed fuse links specifically designed for protecting and isolating photovoltaic array combiners and disconnects. These fuse links are capable of interrupting low overrated currents associated with faulted PV systems (reverse rated current, multi-array fault).

#### Technical data

- Rated voltage:
  - 1000 V d.c. (IEC and UL 63 to 600 A)
  - 1500 V d.c. (IEC and UL 50 to 500 A)
- Rated current: 50 A to 600 A
- Breaking capacity: see Catalog numbers tables
- Operating class: gPV and UL PV fuse links

#### Compatible fuse base

- SD-S-PV

#### Microswitches

- For bladed fuse links
  - 170H0235 or 170H0237 for 01XL
  - 170H0236 or 170H0238 for 1XL, 2XL and 3L
- For bolted fuse links
  - 170H0069 for all sizes



#### Standards / Agency information

IEC 60269-6, UL Recognised file 2579 E335324, RoHS compliant

#### Catalog numbers - PV-XL fuse links, 1000 V d.c.

Fuse link body size	Rated voltage	Rated current (Amps)	Breaking capacity (IEC/UL) (kA)	I <sup>2</sup> t (A <sup>2</sup> Sec)		Watts loss (W)		Catalog numbers	
				Pre-arcing	Total at 1000 V d.c.	0.7 I <sub>n</sub>	I <sub>n</sub>	Bladed version	Bolted version
01	1000 V d.c.	63	50	260	1900	10	24	PV-63A-01XL	PV-63A-01XL-B
		80	50	490	3600	12	29	PV-80A-01XL	PV-80A-01XL-B
		100	50	870	6300	13	32	PV-100A-01XL	PV-100A-01XL-B
		125	50	1930	13,900	16	40	PV-125A-01XL	PV-125A-01XL-B
		160	50	3900	28,100	18	44	PV-160A-01XL	PV-160A-01XL-B
2	1000 V d.c.	160	33	2780	21,000	18	44	PV-160A-2XL	PV-160A-2XL-B
		200	33	4950	37,000	20	50	PV-200A-2XL	PV-200A-2XL-B
		250	33	9450	70,000	24	60	PV-250A-2XL	PV-250A-2XL-B
		315	33	16,600	123,000	26	66	PV-315A-2XL	PV-315A-2XL-B
		355	33	26,000	192,000	27	68	PV-355A-2XL	PV-355A-2XL-B
		160	33	2780	21,000	18	44		PV-160A-2XL-3B <sup>1</sup>
		200	33	4950	37,000	20	50		PV-200A-2XL-3B <sup>1</sup>
		250	33	9450	70,000	24	60		PV-250A-2XL-3B <sup>1</sup>
		315	33	16,600	123,000	26	66		PV-315A-2XL-3B <sup>1</sup>
		355	33	26,000	192,000	27	68		PV-355A-2XL-3B <sup>1</sup>
3	1000 V d.c.	350	50	31,000	161,200	26	65	PV-350A-3L	PV-350A-3L-B
		400	50	44,500	231,400	33	82	PV-400A-3L	PV-400A-3L-B
		500	50	85,000	442,000	34	85	PV-500A-3L	PV-500A-3L-B
		600	50	137,000	712,400	43	108	PV-600A-3L	PV-600A-3L-B

<sup>1</sup> PV-\*A-2XL-3B and PV-\*A-2XL-3B-15 have revised bolting patterns, which are identical to size 3L bolting pattern. This allows utilisation of both size 2XL and size 3L fuse links without changing the dimensional layout of the inverter, combiners and disconnects.

Data sheets: [10201 for PV fuse links](#) / [TD135020 for PVS fuse links](#)

## 1000-1500 V d.c. (IEC/UL) - 50 A to 600 A - PV-XL and PVS-3L - XL and 3L Style

### Catalog numbers - PV-XL fuse links, 1500 V d.c.

Fuse link body size	Rated voltage	Rated current (Amps)	Breaking capacity (IEC/UL) (kA)	I <sup>2</sup> t (A <sup>2</sup> Sec)		Watts loss (W)		Catalog numbers			
				Pre-arcing	Total at 1500 V <sup>1</sup>	0.7 I <sub>n</sub>	I <sub>n</sub>	Bladed with top indicator	Bladed without top indicator	Bolted version with side indicator	Bolted without side indicator
01	1500 V d.c.	50	30	175	1000	10	25	PV-50A-01XL-15		PV-50A-01XL-B-15	
		63	30	362	2250	10	26	PV-63A-01XL-15		PV-63A-01XL-B-15	
		80	30	565	3300	14	35	PV-80A-01XL-15		PV-80A-01XL-B-15	
		100	30	1100	6600	16	40	PV-100A-01XL-15		PV-100A-01XL-B-15	
		125	30	2200	10,500	18	44	PV-125A-01XL-15		PV-125A-01XL-B-15	
1	1500 V d.c.	100	30	1250	6000	24	43	PV-100A-1XL-15		PV-100A-1XL-B-15	
		125	30	1950	9360	25	52	PV-125A-1XL-15		PV-125A-1XL-B-15	
		160	30	4200	20,160	26	54	PV-160A-1XL-15		PV-160A-1XL-B-15	
		200	30	9400	45,120	31	60	PV-200A-1XL-15		PV-200A-1XL-B-15	
2	1500 V d.c.	125	30	2200	15,000	18	44	PV-125A-2XL-U-15	PV-125A-2XL-U-15	PV-125A-2XL-B-15	PV-125A-2XL-BU-15
		160	30	5000	32,000	19	48	PV-160A-2XL-U-15	PV-160A-2XL-U-15	PV-160A-2XL-B-15	PV-160A-2XL-BU-15
		200	30	8800	51,000	23	57	PV-200A-2XL-U-15	PV-200A-2XL-U-15	PV-200A-2XL-B-15	PV-200A-2XL-BU-15
		250	30	16,600	85,000	28	70	PV-250A-2XL-U-15	PV-250A-2XL-U-15	PV-250A-2XL-B-15	PV-250A-2XL-BU-15
		125	30	2200	15,000	18	44			PV-125A-2XL-3B-151	PV-125A-2XL-3BU-151
		160	30	5000	32,000	19	48			PV-160A-2XL-3B-151	PV-160A-2XL-3BU-151
		200	30	8800	51,000	23	57			PV-200A-2XL-3B-151	PV-200A-2XL-3BU-151
		250	30	16,600	85,000	28	70			PV-250A-2XL-3B-151	PV-250A-2XL-3BU-151
3	1500 V d.c.	250	100	90,000	350,000	24	43	PVS250A-3L-15	PVS250A-3L-U-15	PVS250A-3L-B-15	PVS250A-3L-BU-15
		315	100	175,000	460,000	22	55	PVS315A-3L-15	PVS315A-3L-U-15	PVS315A-3L-B-15	PVS315A-3L-BU-15
		350	100	250,000	970,000	23	57	PVS350A-3L-15	PVS350A-3L-U-15	PVS350A-3L-B-15	PVS350A-3L-BU-15
		355	100	250,000	970,000	23	59	PVS355A-3L-15	PVS355A-3L-U-15	PVS355A-3L-B-15	PVS355A-3L-BU-15
		400	100	315,000	1,100,000	27	71	PVS400A-3L-15	PVS400A-3L-U-15	PVS400A-3L-B-15	PVS400A-3L-BU-15
		450	100 <sup>2</sup>	412,000	1,470,000	27	67	PV-450A-3L-15	PV-450A-3L-U-15	PV-450A-3L-B-15	PV-450A-3L-BU-15
		500	100 <sup>2</sup>	532,000	1,890,000	29	73	PV-500A-3L-15	PV-500A-3L-U-15	PV-500A-3L-B-15	PV-500A-3L-BU-15

<sup>1</sup> PV-\*A-2XL-3B and PV-\*A-2XL-3B-15 have revised bolting patterns, which are identical to size 3L bolting pattern. This allows utilisation of both size 2XL and size 3L fuse links without changing the dimensional layout of the inverter, combiners and disconnects.

<sup>2</sup> 100 kA at time constant 6ms.

# Photovoltaic fuse links, fuse bases and holders

## 1000-1500 V d.c. (IEC/UL) - 50 A to 600 A - PV-XL and PVS-3L - XL and 3L Style

### Dimensions (mm) - Size 01, bladed

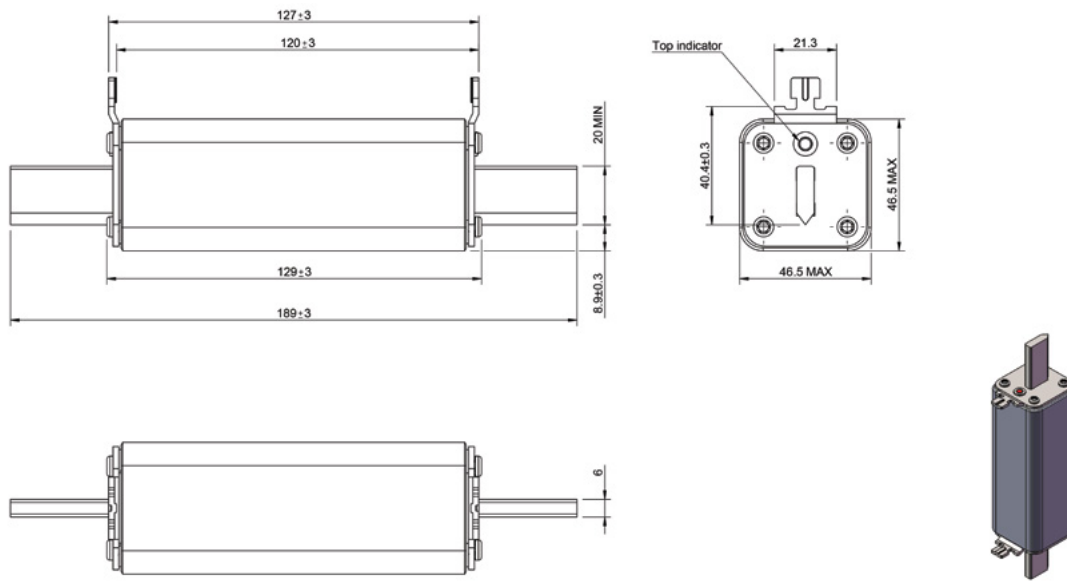

### Dimensions (mm) - Size 1, bladed

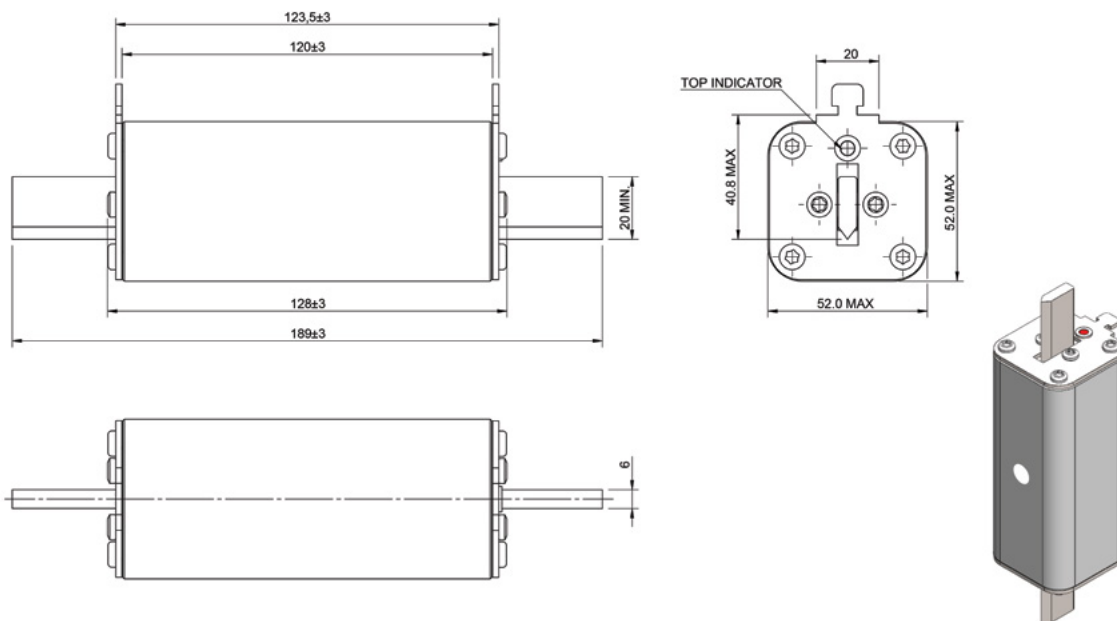

1000-1500 V d.c. (IEC/UL) - 50 A to 600 A - PV-XL and PVS-3L - XL and 3L Style

Dimensions (mm) - Size 2, bladed

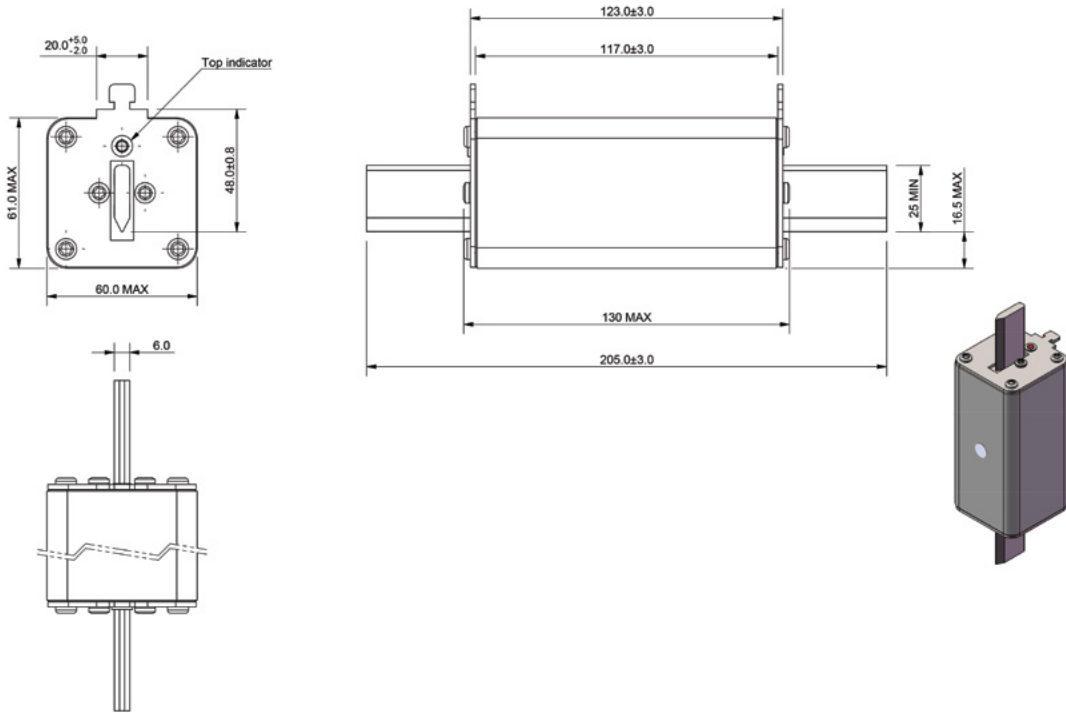

Dimensions (mm) - Size 3, bladed

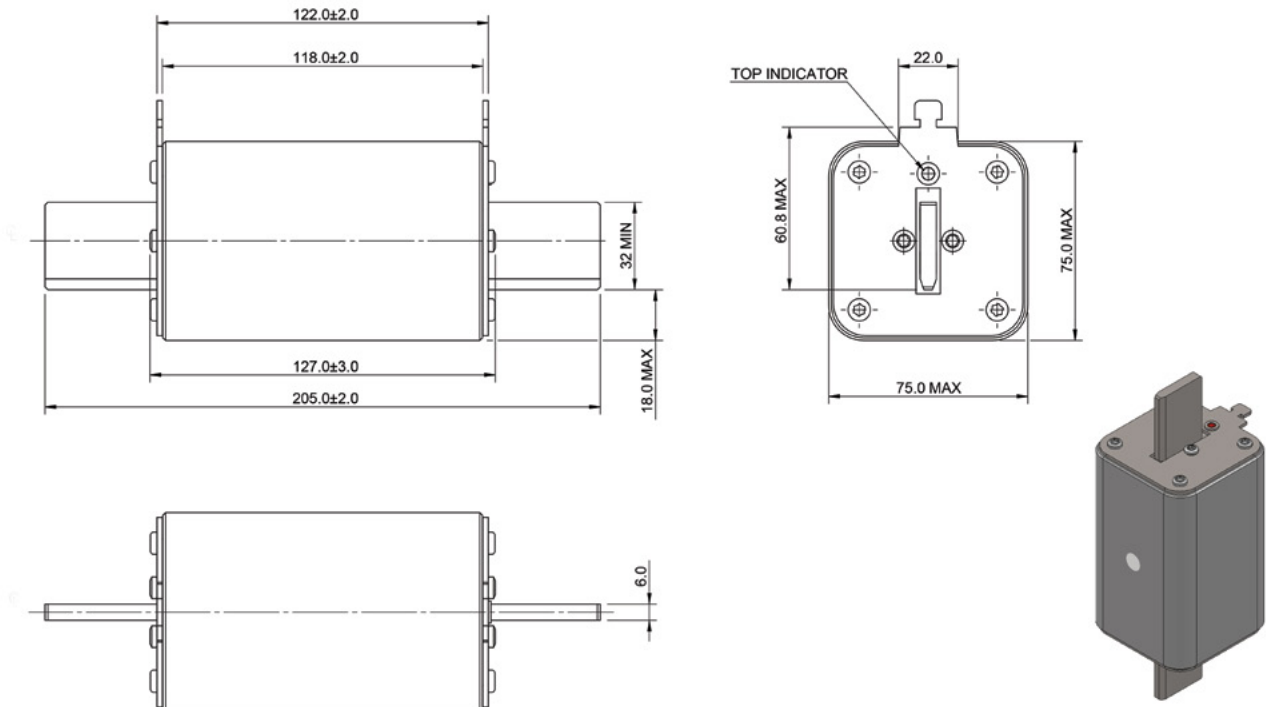

# Photovoltaic fuse links, fuse bases and holders

## 1000-1500 V d.c. (IEC/UL) - 50 A to 600 A - PV-XL and PVS-3L - XL and 3L Style

Dimensions (mm) - Size 01, bolted

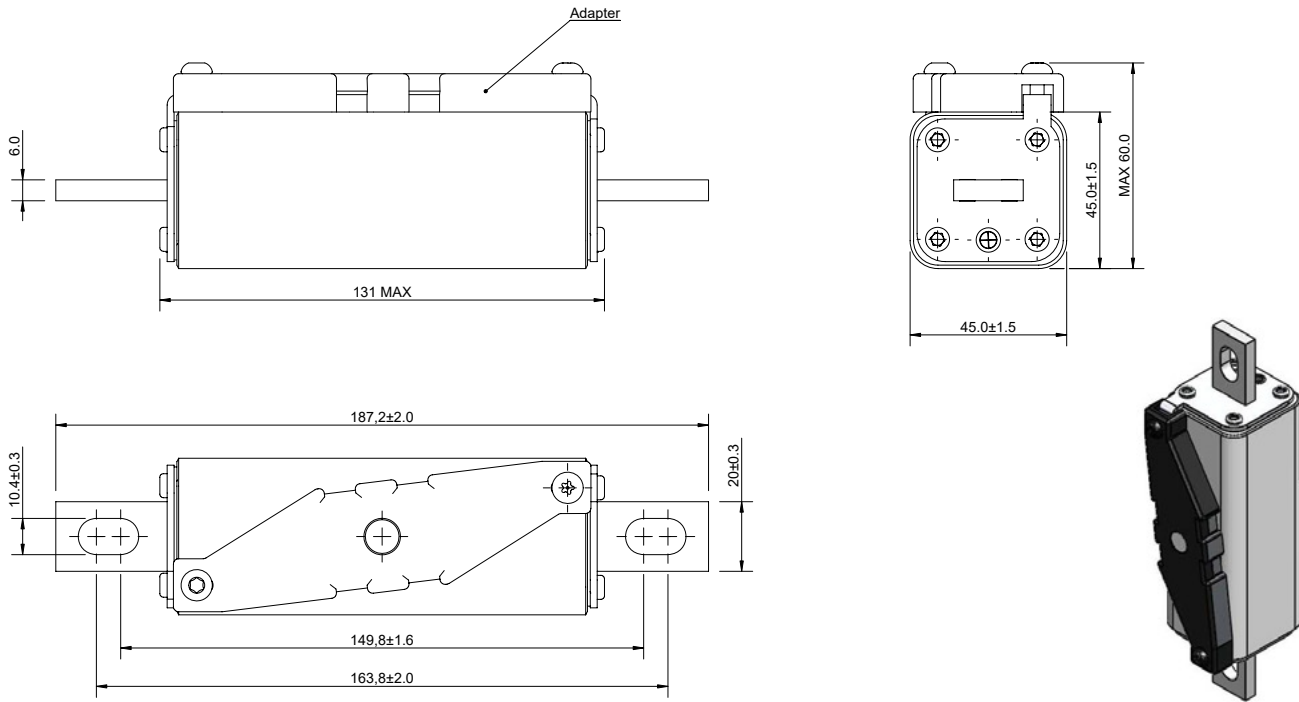

Dimensions (mm) - Size 1, bolted

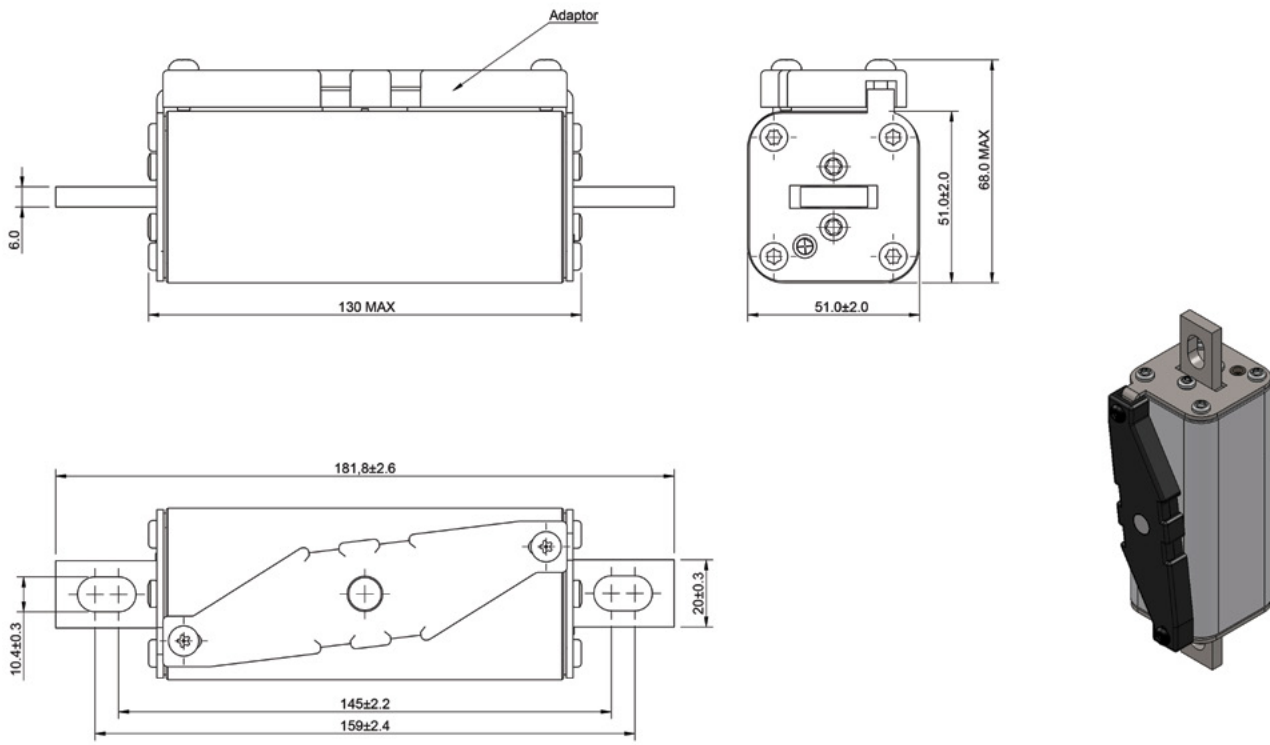

Data sheets: [10201 for PV fuse links](#) / [TD135020 for PVS fuse links](#)

1000-1500 V d.c. (IEC/UL) - 50 A to 600 A - PV-XL and PVS-3L - XL and 3L Style

Dimensions (mm) - Size 2, bolted

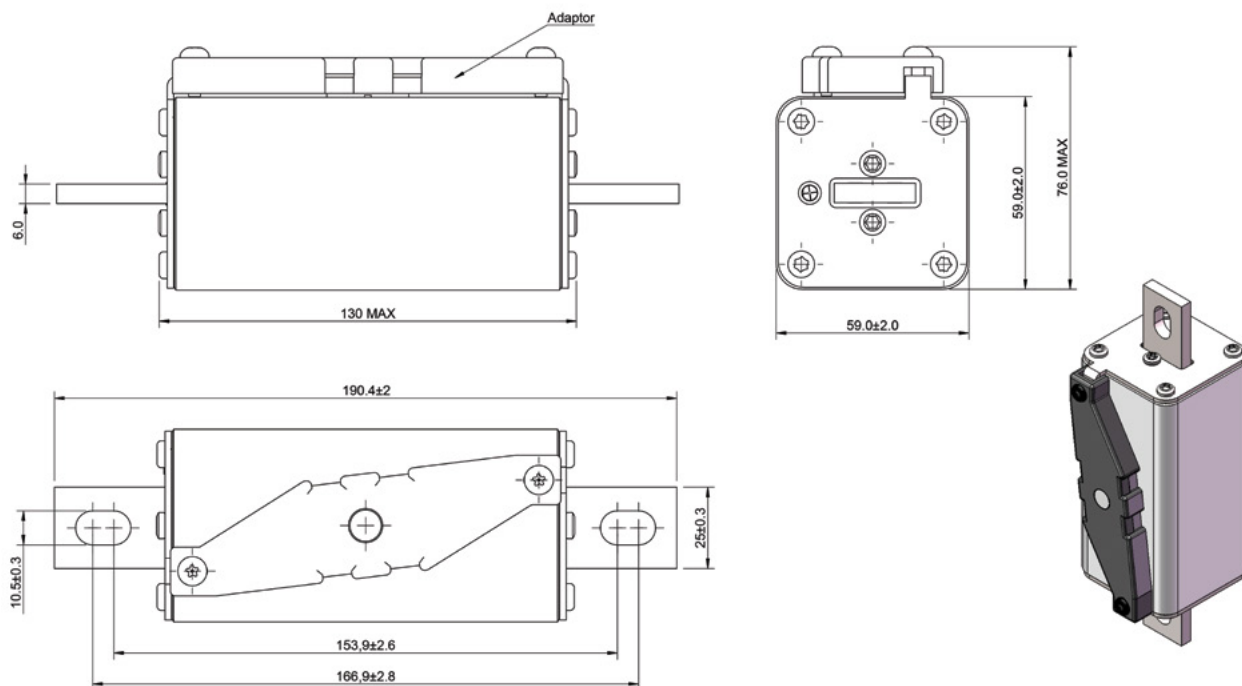

Dimensions (mm) - Size 2XL-3B, bolted

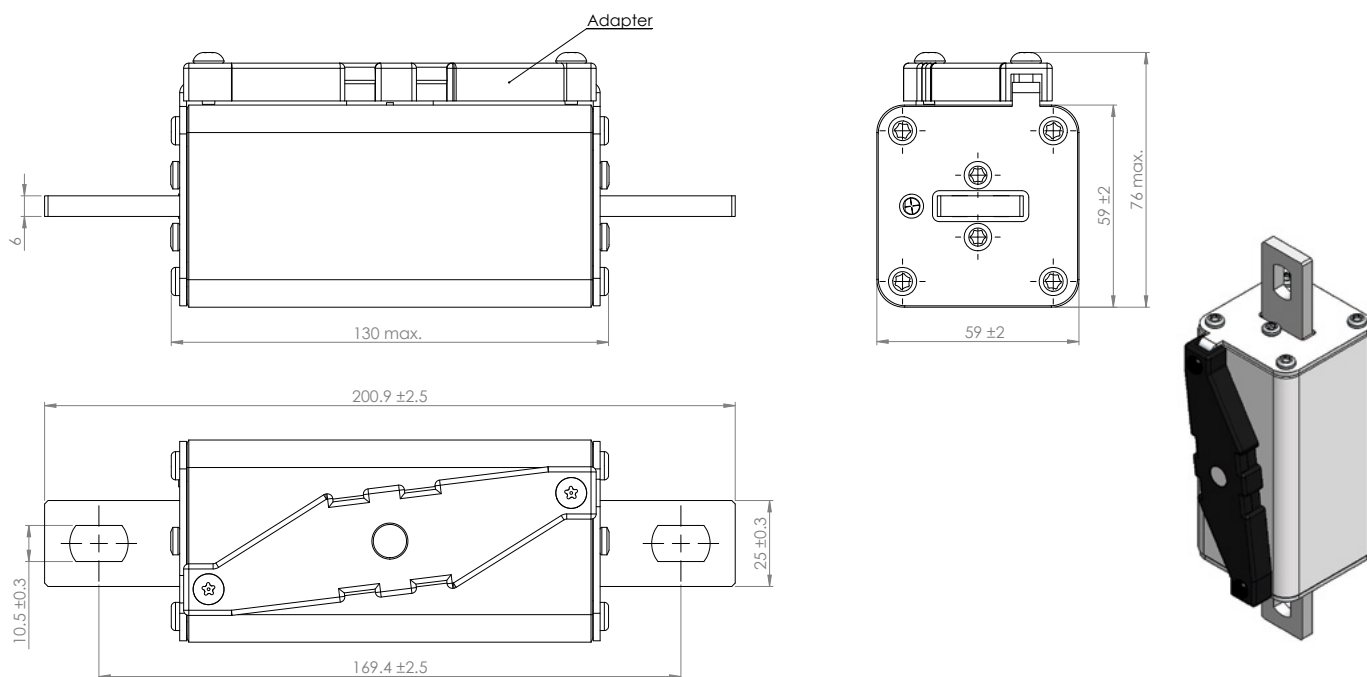

PV-\*A-2XL-3B and PV-\*A-2XL-3B-15 have revised bolting patterns, which are identical to size 3L bolting pattern. This allows utilisation of both size 2XL and size 3L fuse links without changing the dimensional layout of the inverter, combiners and disconnects.

Mounting dimensions comparison

2XL-3B	3L
169.4	170.8

Data sheets: [10201 for PV fuse links](#) / [TD135020 for PVS fuse links](#)

# Photovoltaic fuse links, fuse bases and holders

## 1000-1500 V d.c. (IEC/UL) - 50 A to 600 A - PV-XL and PVS-3L - XL and 3L Style

Dimensions (mm) - Size 3, bolted

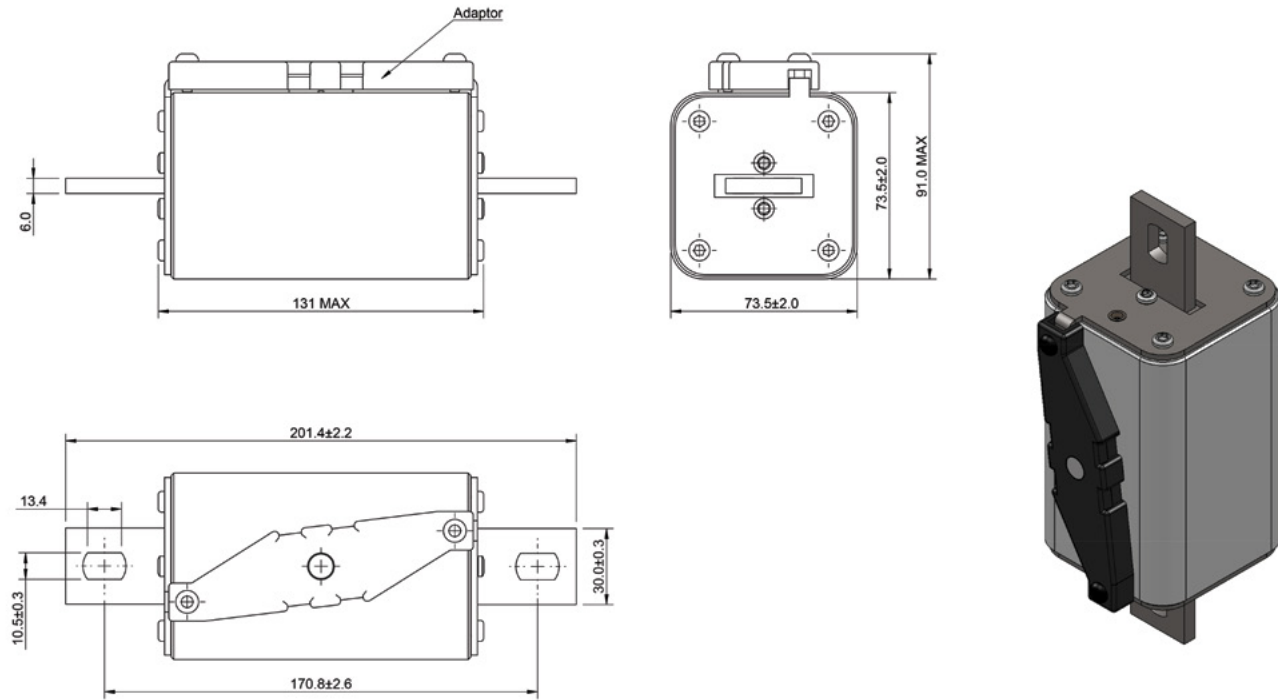

### Time-current curve - Size 01XL, bladed and bolted, 1000 V d.c., 63 A to 160 A

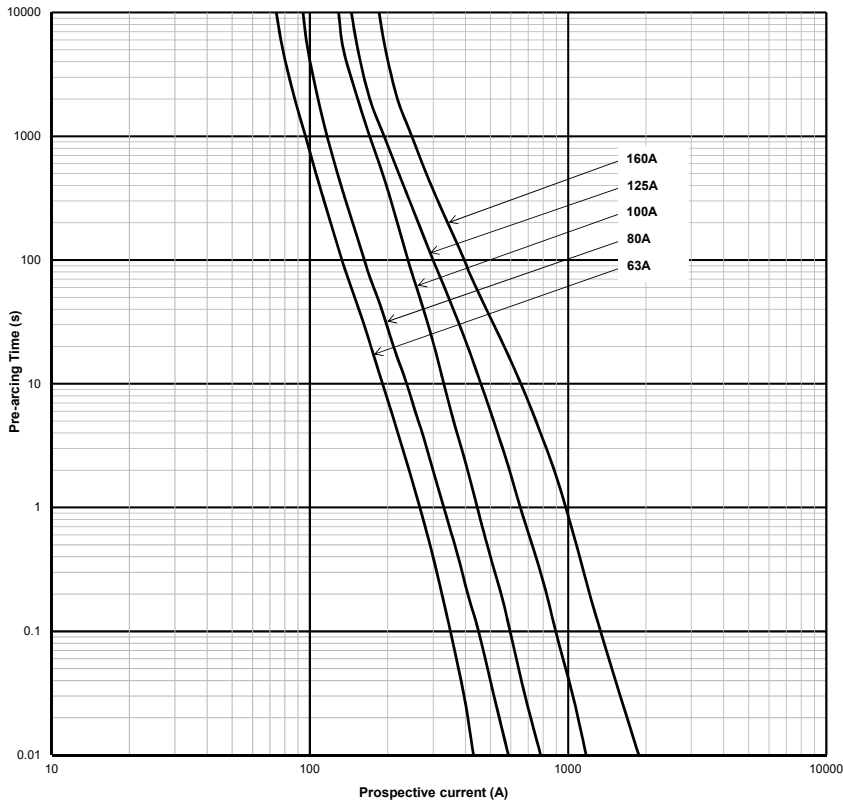

Data sheets: [10201 for PV fuse links](#) / [TD135020 for PVS fuse links](#)

1000-1500 V d.c. (IEC/UL) - 50 A to 600 A - PV-XL and PVS-3L - XL and 3L Style

Time-current curve - Size 2XL, bladed and bolted, 1000 V d.c., 160 A to 355 A

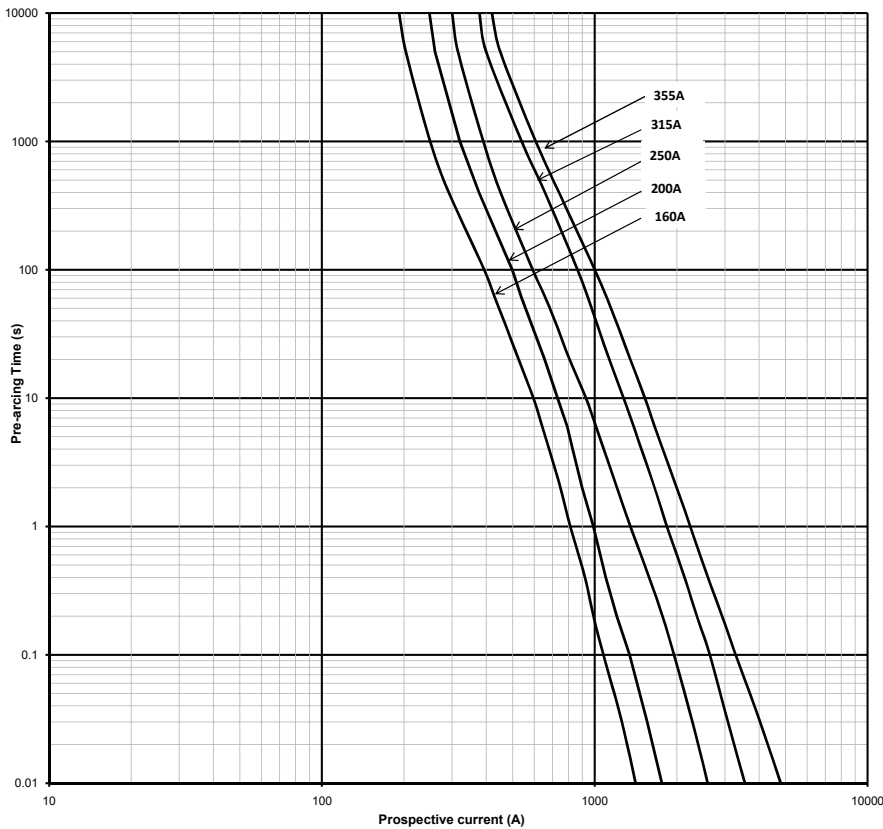

Time-current curve - Size 3L, bladed and bolted, 1000 V d.c., 350 A to 600 A

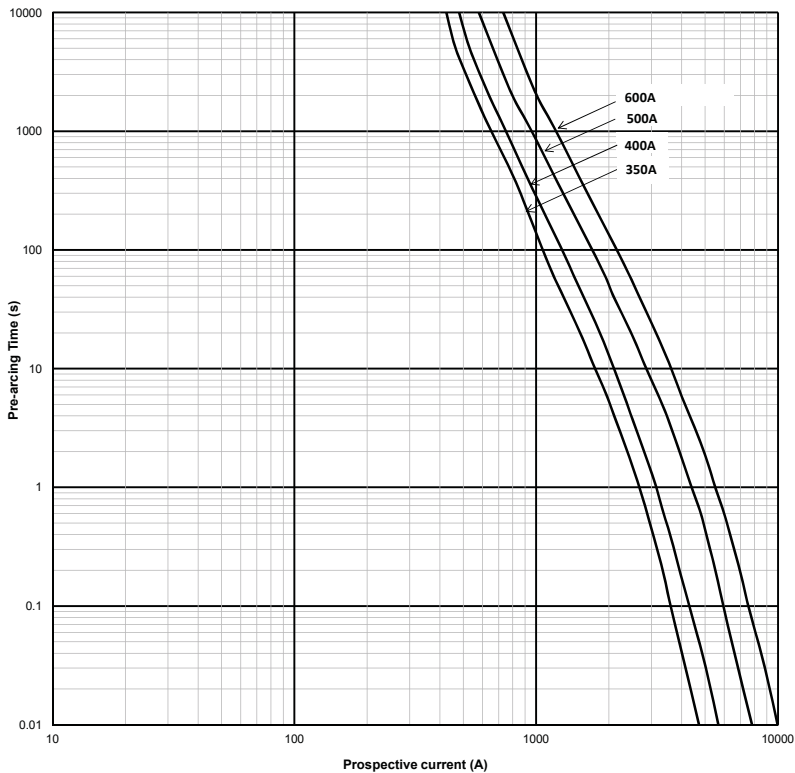

Data sheets: [10201 for PV fuse links](#) / [TD135020 for PVS fuse links](#)

# Photovoltaic fuse links, fuse bases and holders

## 1000-1500 V d.c. (IEC/UL) - 50 A to 600 A - PV-XL and PVS-3L - XL and 3L Style

Time-current curve - Size 01XL, bladed and bolted, 1500 V d.c., 50 A to 125 A

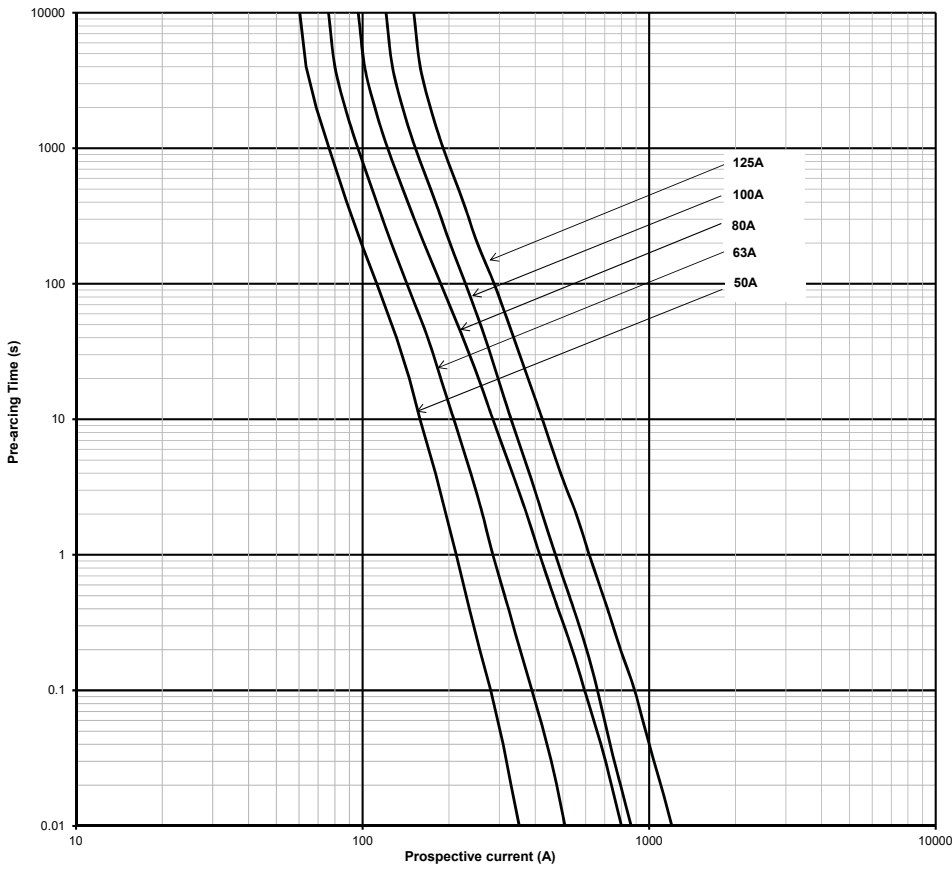

Time-current curve - Size 1XL, bladed and bolted, 1500 V d.c., 100 A to 200 A

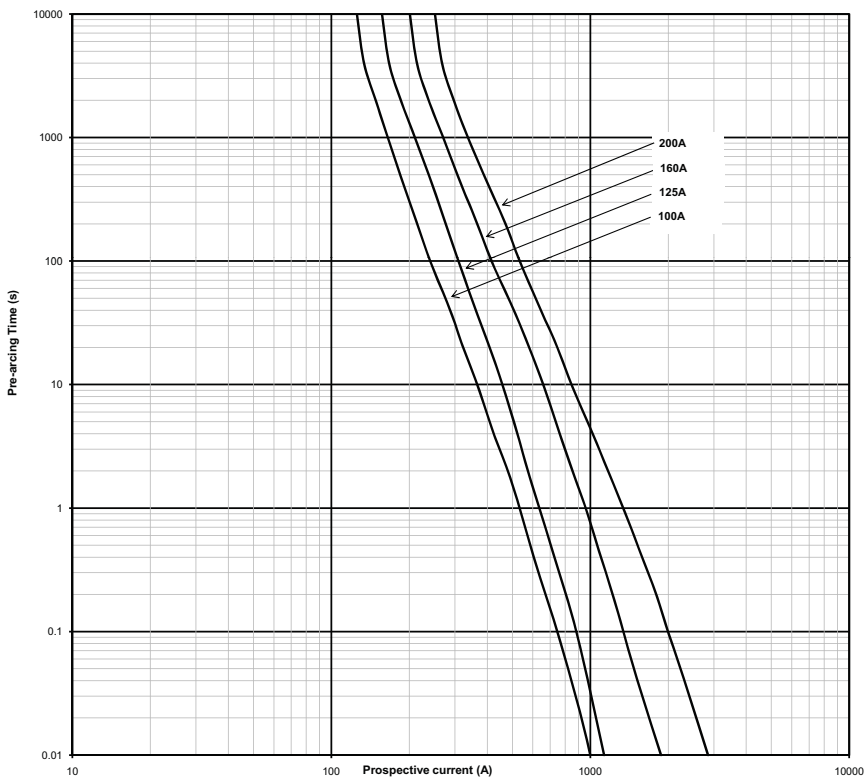

Data sheets: [10201 for PV fuse links](#) / [TD135020 for PVS fuse links](#)

1000-1500 V d.c. (IEC/UL) - 50 A to 600 A - PV-XL and PVS-3L - XL and 3L Style

Time-current curve - Size 2XL, bladed and bolted, 1500 V d.c., 125 A to 250 A

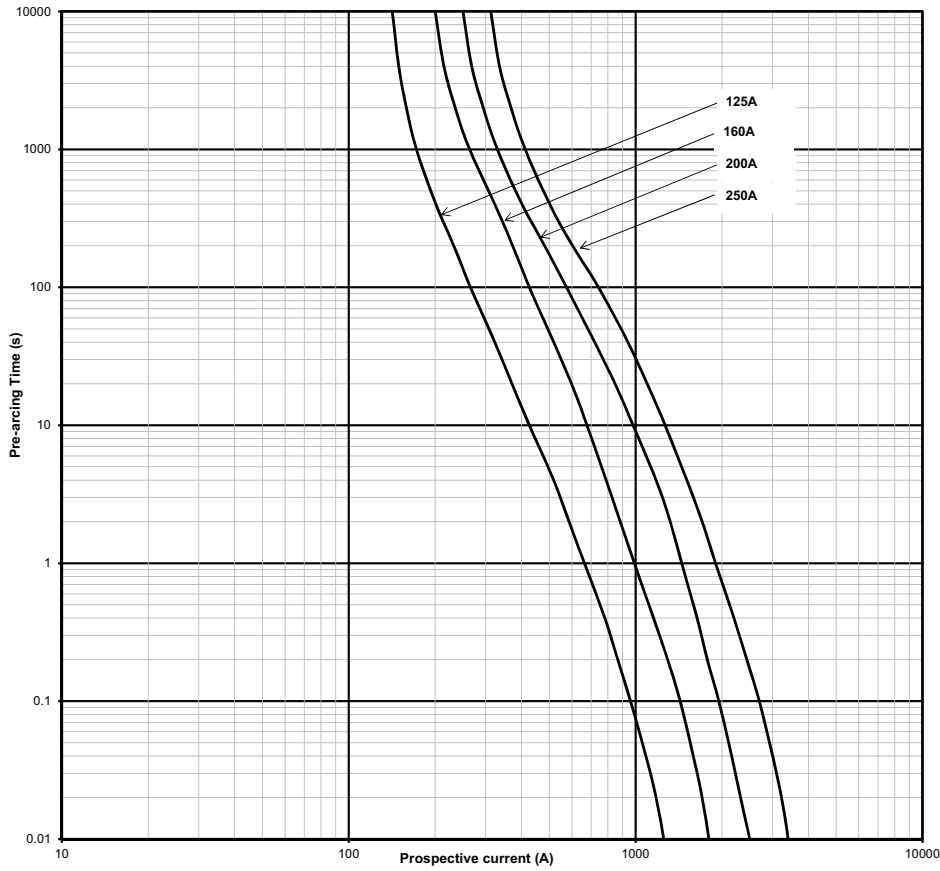

Time-current curve - Size PVS- 3L, bladed and bolted, 1500 V d.c., 250 A to 400 A

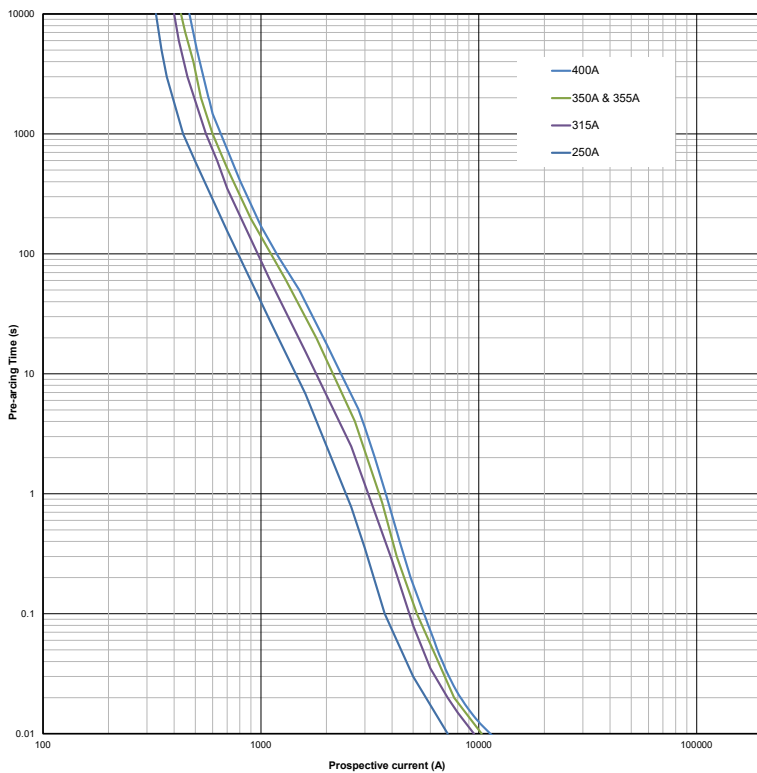

Data sheets: [10201 for PV fuse links](#) / [TD135020 for PVS fuse links](#)

# Photovoltaic fuse links, fuse bases and holders

## 1000-1500 V d.c. (IEC/UL) - 50 A to 600 A - PV-XL and PVS-3L - XL and 3L Style

Time-current curve - 3L, bladed and bolted, 1500 V d.c., 450 A and 500 A

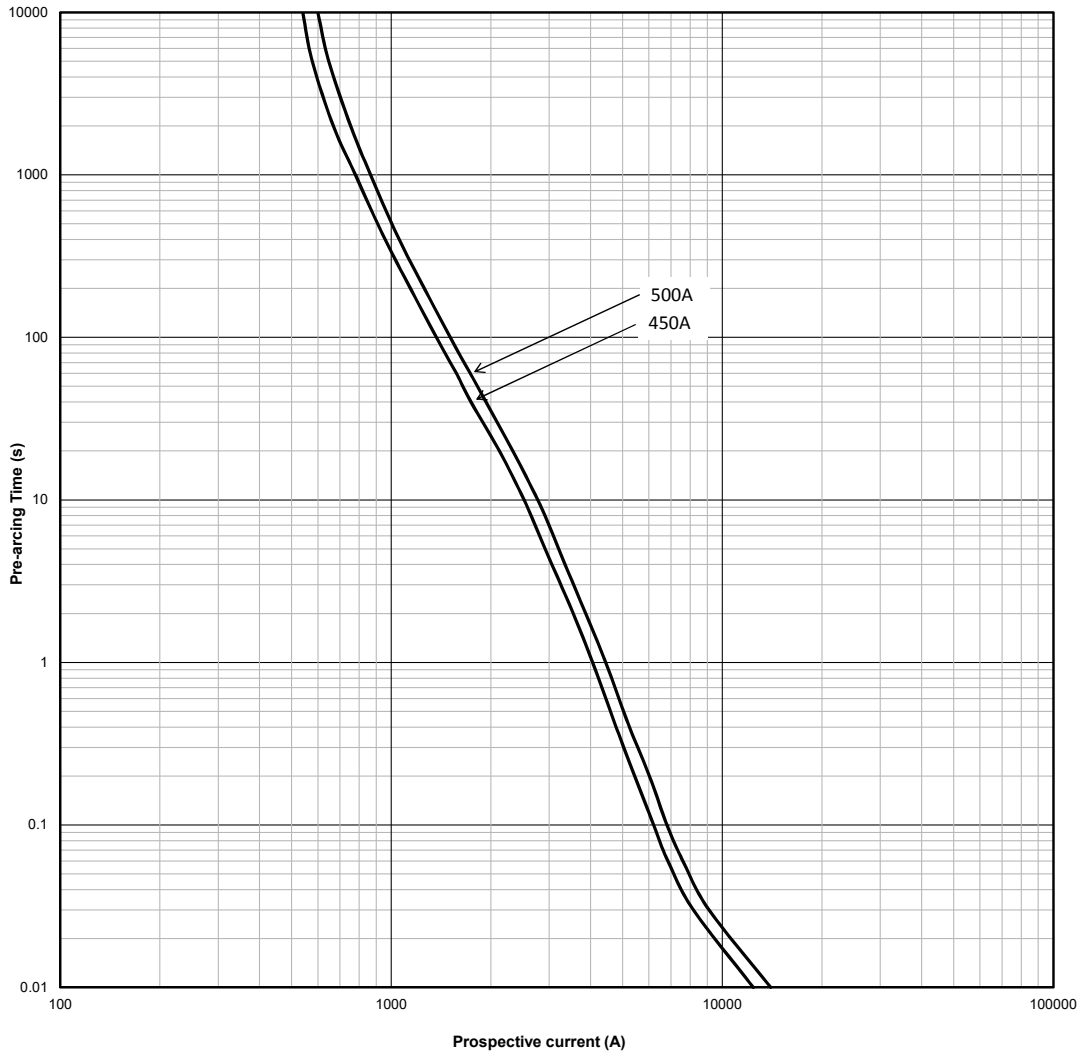

### Temperature derating curve

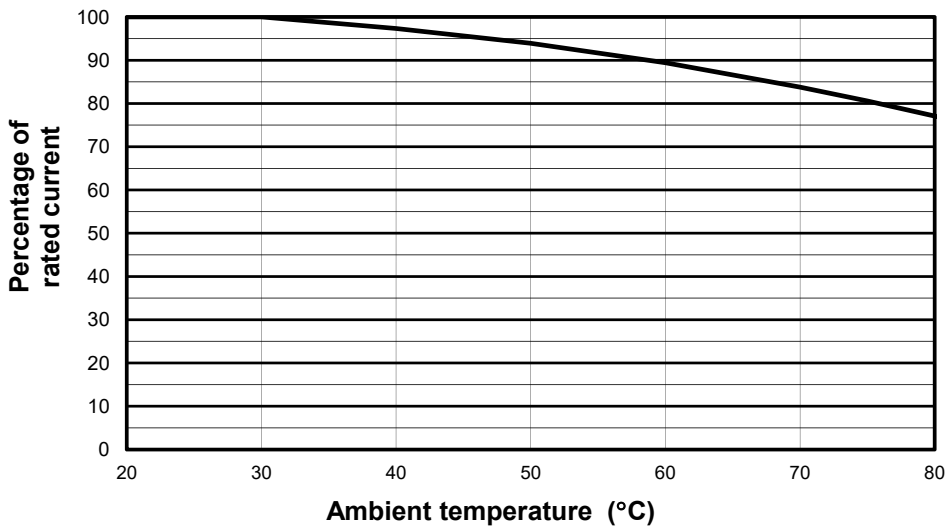

Data sheets: [10201 for PV fuse links](#) / [TD135020 for PVS fuse links](#)

## SD-S-PV Fuse base for XL and PVS fuse links - 1500 V d.c. (IEC) - 200 A to 500 A

### Specifications

#### Description

Sizes 1 to 3 XL Fuse bases specifically designed for use with the Bussmann series range of XL PV (Photovoltaic) fuse links.

#### Technical data

- Rated voltage: 1500 V d.c. (IEC)
- Rated current: 200 A, 400 A and 630 A
- Fuse base size: 1 to 3
- Compatible with our 1000 V d.c and 1500 V d.c. PV-XL and PV-3L fuse links ranges.

#### Standards / Agency information

- IEC 60269-1
- UL Listed (file number E348242)

#### Accessories:

Fuse extraction handle available in sizes 01XL to 3L

Part numbers: FEH1500B

Unit packing: 1



#### Catalog numbers

Catalog numbers	XL Style fuse link size	Maximum fuse rated current (Amps)	Power acceptance
SD1XL-S-PV	01XL, 1XL	200	57W
SD2XL-S-PV	2XL	400	75W
SD3L-S-PV	3L	500	108W

#### Dimensions (mm)

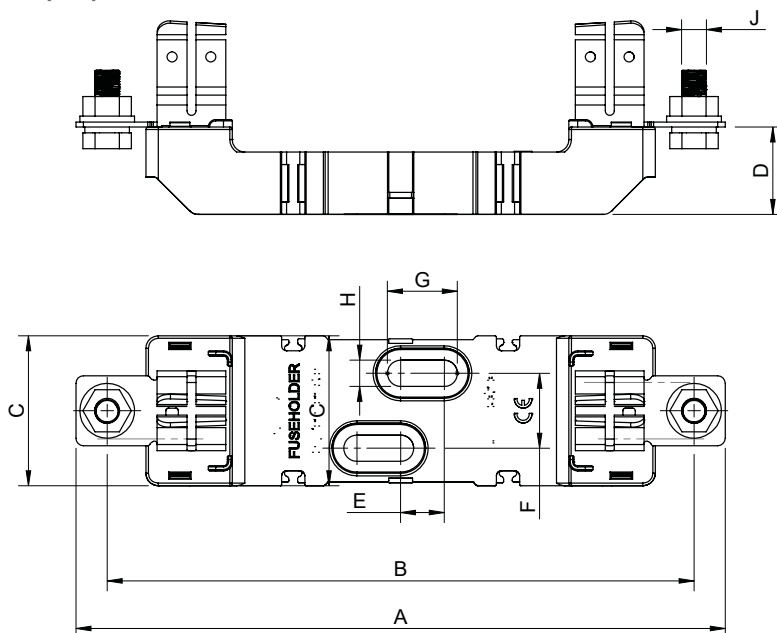

Catalog numbers	A	B	C	D	E	F	G	H	J
SD1XL-S-PV	260	235	60	35	17.5	30	28	10.5	M10
SD2XL-S-PV	285	260	60	35	17.5	30	28	10.5	M12
SD3L-S-PV	300	270	60	35	17.5	30	28	10.5	M12

Data sheet: [10685](#)

# Photovoltaic fuse links, fuse bases and holders

## 2000 V d.c. Photovoltaic fuses

In response to the rapid growth of solar power systems and the increasing utilisation of high-voltage string and central inverters, Eaton is prioritising the development of 2000 V d.c. gPV fuses. These are specifically designed to address the evolving protection requirements of contemporary photovoltaic (PV) installations.

PV systems pose distinctive challenges for overcurrent protection, such as prolonged fault currents, elevated ambient temperatures, and the necessity for reliable direct current arc interruption. Eaton's gPV fuses are engineered to overcome these obstacles by providing fast-acting protection, high DC voltage ratings, and robust performance even in demanding outdoor conditions.

As system voltages in the PV sector continue to increase, frequently surpassing 1500 V d.c., Eaton is actively advancing its gPV fuse portfolio in accordance with **the upcoming IEC 63523 (for fuses rated above 1500 V d.c.) and UL 248-19 (for fuses rated up to 2000 V d.c.)**. These standards establish the requirements for fuses rated above 1500 V d.c., ensuring that Eaton's products remain compliant with future regulatory frameworks while delivering reliable, safe protection for next-generation solar infrastructure.

Eaton's gPV fuse range is suitable for use in combiner boxes, string inverters, and battery-integrated PV systems, ensuring dependable performance and reassurance for professionals working in the solar energy industry.



### Technical data

- Rated voltage: 2000 V d.c.
- Rated current: various options available
- Operating class: gPV
- Connection type: DIN 43653 and US Bolted

### Standards / Agency information

IEC 63523 (Draft) and UL 248-19, ROHS compliant

For inquiries related to your 2000 V d.c. PV System development, please contact [bulehighspeedtechnical@eaton.com](mailto:bulehighspeedtechnical@eaton.com)

# Index

180D0009	39	180D3513	40	180D4392	57	180D6544	62	180D8751	114
180D0010	39	180D3514	40	180D4393	57	180D6545	62	180D8752	114
180D0011	39	180D3515	40	180D4394	57	180D6546	62	180D8753	114
180D0012	39	180D3516	40	180D4395	48	180D6785	69	180D8754	114
180D0013	39	180D3517	40	180D4396	48	180D6786	69	180D8755	114
180D0014	39	180D3518	40	180D4397	48	180D6787	69	180D8756	114
180D0015	39	180D3519	40	180D4438	57	180D6788	69	180D8757	114
180D0016	39	180D3520	40	180D4439	57	180D6789	69	180D8758	114
180D0017	39	180D3521	40	180D4440	57	180D6790	69	180D8759	114
180D0018	39	180D3559	40	180D4441	57	180D6791	69	180D8760	114
180D0019	39	180D3560	40	180D4442	57	180D6794	69	BSF-3XL	119
180D0020	39	180D3561	40	180D4443	57	180D6806	69	BSF-DD25	31
180D0021	39	180D3562	40	180D4444	57	180D6827	69	BSF-NH	72
180D346	39	180D3563	40	180D4489	57	180D7420	93	CHPV	137
180D569	105	180D3564	40	180D4490	57	180D7421	93	CHPV14	153
180D1506	45	180D3565	40	180D4491	57	180D7422	93	CHPV15H85	156
180D1507	45	180D3566	40	180D4492	57	180D7423	93	CHSF	9
180D1508	45	180D3567	40	180D4493	57	180D7424	93	EET	26
180D1602	36	180D3568	40	180D4494	57	180D7425	93	ESS2	97
180D1603	36	180D3569	40	180D4495	48	180D7426	93	ESS3	110
180D1604	36	180D3570	40	180D4496	48	180D7427	93	ESS5	125
180D1605	36	180D3571	40	180D4497	48	180D7428	93	FE	26
180D1606	36	180D3615	90	180D5388	78	180D7429	93	FEE	26
180D1608	84	180D3616	90	180D5389	78	180D7430	93	FWE	20
180D1609	84	180D3617	90	180D5390	78	180D7431	93	FWH	12
180D1610	84	180D3618	90	180D5391	78	180D7432	93	FWP	33
180D1611	84	180D3619	90	180D5392	78	180D7433	93	FWP-A14F	33
180D1612	84	180D3620	90	180D5393	78	180D7434	93	FWP-B	15
180D2017	66	180D3688	52	180D5394	78	180D7435	93	FWX	7
180D2018	66	180D3689	52	180D5395	78	180D7436	93	PV-14F	151
180D2019	66	180D3690	52	180D5447	81	180D7437	93	PV-14L	157
180D2020	66	180D3691	52	180D5448	81	180D7462	122	PV-A10	134
180D2021	66	180D3692	52	180D5500	81	180D7463	122	PV-A10F85L	154
180D2612	87	180D3693	52	180D5700	105	180D7477	122	PV-AF	148
180D2613	87	180D3694	52	180D5701	105	180D7620	122	PV-ANH	138
180D2614	87	180D3695	52	180D5702	105	180D7627	122	PVM	132
180D2615	87	180D3696	52	180D5703	105	180D7698	122	PVS-3L	160
180D3388	52	180D3697	52	180D5704	105	180D7739	128	PV-XL	160
180D3389	52	180D3738	52	180D5705	105	180D7740	128	SD1XL-S-PV	171
180D3390	52	180D3739	52	180D5706	105	180D7741	128	SD-D-PV	146
180D3391	52	180D3740	52	180D5707	105	180D7742	128	SD-S-PV	171
180D3392	52	180D3741	52	180D5849	105	180D7743	128		
180D3393	52	180D3742	52	180D5850	105	180D7744	128		
180D3394	52	180D3743	52	180D5851	105	180D7745	128		
180D3395	52	180D3744	52	180D5852	105	180D8722	114		
180D3396	52	180D3745	52	180D5853	105	180D8723	114		
180D3397	52	180D3746	52	180D5854	105	180D8724	114		
180D3459	39	180D3747	52	180D5855	105	180D8725	114		
180D3460	39	180D4138	57	180D5856	105	180D8726	114		
180D3461	39	180D4139	57	180D5857	105	180D8727	114		
180D3462	39	180D4140	57	180D5949	105	180D8728	114		
180D3463	39	180D4141	57	180D5950	105	180D8729	114		
180D3464	39	180D4142	57	180D5951	105	180D8730	114		
180D3466	39	180D4143	57	180D5952	105	180D8731	114		
180D3467	39	180D4144	57	180D5953	105	180D8732	114		
180D3468	39	180D4188	57	180D5954	105	180D8733	114		
180D3469	39	180D4189	57	180D5955	105	180D8734	114		
180D3470	39	180D4190	57	180D5956	105	180D8735	114		
180D3471	39	180D4191	57	180D5957	105	180D8736	114		
180D3488	52	180D4192	57	180D6188	62	180D8737	114		
180D3489	52	180D4193	57	180D6189	62	180D8738	114		
180D3490	52	180D4194	57	180D6190	62	180D8739	114		
180D3491	52	180D4238	57	180D6191	62	180D8740	114		
180D3492	52	180D4239	57	180D6192	62	180D8741	114		
180D3493	52	180D4240	57	180D6193	62	180D8742	114		
180D3494	52	180D4241	57	180D6194	62	180D8743	114		
180D3495	52	180D4242	57	180D6195	62	180D8744	114		
180D3496	52	180D4243	57	180D6538	62	180D8745	114		
180D3497	52	180D4244	57	180D6539	62	180D8746	114		
180D3509	40	180D4388	57	180D6540	62	180D8747	114		
180D3510	40	180D4389	57	180D6541	62	180D8748	114		
180D3511	40	180D4390	57	180D6542	62	180D8749	114		
180D3512	40	180D4391	57	180D6543	62	180D8750	114		





Eaton is an intelligent power management company dedicated to protecting the environment and improving the quality of life for people everywhere. We make products for the data center, utility, industrial, commercial, machine building, residential, aerospace and mobility markets. We are guided by our commitment to do business right, to operate sustainably and to help our customers manage power - today and well into the future. By capitalizing on the global growth trends of electrification and digitalization, we're helping to solve the world's most urgent power management challenges and building a more sustainable society for people today and generations to come.

Founded in 1911, Eaton has continuously evolved to meet the changing and expanding needs of our stakeholders. With revenues of nearly \$25 billion in 2024, the company serves customers in more than 160 countries.

For more information, visit [eaton.com](https://www.eaton.com). Follow us on [LinkedIn](#).



**Eaton**

EMEA Headquarters  
Route de la Longeraie 7  
1110 Morges, Switzerland  
[Eaton.com](https://www.eaton.com)

**Electrical Sector**

Eaton Electrical Products Limited  
Unit 1, Hawker Business Park  
Melton Road  
Burton-on-the-Wolds LE12 5TH  
United Kingdom

© 2026 Eaton  
All Rights Reserved  
Printed in XXX  
Publication No. CA135009EN  
March 2026

Changes to the products, to the information contained in this document, and to prices are reserved; so are errors and omissions. Only order confirmations and technical documentation by Eaton is binding. Photos and pictures also do not warrant a specific layout or functionality. Their use in whatever form is subject to prior approval by Eaton. The same applies to Trademarks (especially Eaton, Moeller, and Cutler-Hammer). The Terms and Conditions of Eaton apply, as referenced on Eaton Internet pages and Eaton order confirmations.

Eaton is a registered trademark.

All other trademarks are property of their respective owners.

Follow us on social media to get the latest product and support information.

