



(en) Electric current! Danger to life!
Installation, commissioning and maintenance work must be carried out by qualified personnel only.



(de) Lebensgefahrdurch elektrischen Strom!
Arbeiten bzw. Montage an diesem Produkt dürfen nur von Elektrofachkräften und elektrotechnisch unterwiesenen Personen ausgeführt werden.



(fr) Tension électrique dangereuse !
L'installation de l'appareil, ainsi que tous les travaux effectués sur celui-ci, doivent être réalisés par un électricien qualifié ou par un personnel spécialement formé.



(es) ¡Corriente eléctrica! ¡Peligro de muerte!
La instalación del dispositivo, así como todos los trabajos en él, deben ser realizados por un electricista calificado o por personal especialmente capacitado.



(it) Tensione elettrica: Pericolo di morte!
L'installazione e il lavoro sul dispositivo devono essere effettuati da un elettricista qualificato o da personale specializzato.



(zh) 触电危险!
設備的安裝，以及所有工作，必須由合格的電工或經過專門培訓的人員完成。



(ru) Электрический ток! Опасно для жизни!
Установка и эксплуатация устройства должны выполняться квалифицированным электриком или специально обученным персоналом.



(nl) Levensgevaar door elektrische stroom!
Installatie van het apparaat en alle werkzaamheden eraan, mogen uitsluitend door een gekwalificeerd elektricien of speciaal opgeleid vakpersoneel worden uitgevoerd.



(da) Livsfare på grund af elektrisk strøm!
Arbejde i forbindelse med installation, opstart og vedligehold må kun udføres af kvalificeret personale.



(el) Προσοχή, κίνδυνος ηλεκτροπληξίας!
Η εγκατάσταση, εκκίνηση και συντήρηση θα πρέπει να πραγματοποιείται μόνο από εξειδικευμένο προσωπικό.



(pt) Perigo de vida devido a corrente eléctrica!
A instalação do dispositivo, bem como todos os trabalhos devem ser realizados por um electricista qualificado ou por pessoal especialmente formado.



(sv) Livsfara genom elektrisk ström!
Installation, idrifttagande och underhållsarbete får endast utföras av behörig personal.



(fi) Hengenvaarallinen jännite!
Laitteen asennus ja käyttö ainoastaan sähköasentajan tai siihen perehdytetyn henkilön toimesta.



(cs) Nebezpečí úrazu elektrickým proudem!
Instalace zařízení a veškeré práce na něm musí být provedeny kvalifikovaným elektrikářem nebo speciálně vyškoleným personálem.



(et) Eluohhtik! Elektrilöögiht!
Paigaldus-, kasutus- ja hooldustööd peab läbi viima ainult kvalifitseeritud personal.



(hu) Életveszély az elektromos áram révén!
Az eszköz felszerelését, valamint az ehhez kapcsolódó összes munkát szakképzett villanyszerelővel vagy szakképzett személynéznek kell elvégeznie.



(lv) Elektriskā strāva apdraud dzīvību!
Uzstādīšana, nodošana ekspluatācijā un apkopes darbi jāveic tikai kvalificētam personālam.



(lt) Pavojus gyvybei dėl elektros srovės!
Įrengimo, paleidimo ir techninės priežiūros darbus turi atlikti tik kvalifikuotas personalas.



(pl) Poráženie prądem elektrycznym stanowi zagrożenie dla życia!
Instalacja urządzenia, jak również prace nad nim, muszą być wykonywane przez wykwalifikowanego elektryka lub specjalnie wyszkolony personel.



(sl) Življenjska nevarnost zaradi električnega toka!
Dela montaže, zagona in vzdrževanja morajo izvajati samo usposobljeno osebeje.



(sk) Nebezpečnost ohrozenia života elektrickým prúdom!
Inštalácia prístroja, ako aj všetky práce na ňom musia byť vykonané kvalifikovaným elektrotechnikom alebo špeciálne vyškoleným personálom.



(bg) Опасност за живота от електрически ток!
Инсталирането на устройството, както и всяка работа по него, трябва да бъде извършвано от квалифициран електротехник или от специално обучен персонал.



(ro) Atenție! Pericol electric!
Montajul și lucrul cu acest aparat trebuie făcute numai de un electrician calificat sau de personal tehnic specializat.



(hr) Опасност по живот услед електричне струје!
Radove ugradnje, puštanja u pogon i održavanja mora vršiti samo kvalificirano osoblje.



(tr) Elektrik akımı! Hayati tehlike!
Bu ürünün çalıştırılması veya kurulumu sadece elektroteknik eğitimleri almış olan ehliyetli elektrikçiler ve kişiler tarafından yapılmalıdır.



(sr) Електрична струја! Опасност по живот!
Инсталацију, пуштање у рад и одржавање сме да обавља искључиво квалификовано особље.



(no) Elektrisk strøm! Livsfare!
Installasjon av enheten, samt arbeid på den, skal kun utføres av kvalifisert personell, eller av de som er spesielt opplært til dette arbeidet.



(uk) Електричний струм! Небезпечно для життя!
Встановлення пристрою, так само, як і робота з ним, повинні виконуватись кваліфікованим електриком або персоналом, що пройшов спеціальну підготовку.



(ar) تحذیر! تيار كهربائي! خطر موت!
التثبيت والتكليف و أعمال الصيانة يجب أن تقام فقط من طرف الموظفين المؤهلين

DA1-12...-B6x0

DA1-32...-B6x0

DA1-34...-B6x0

DA1-35...-B6x0

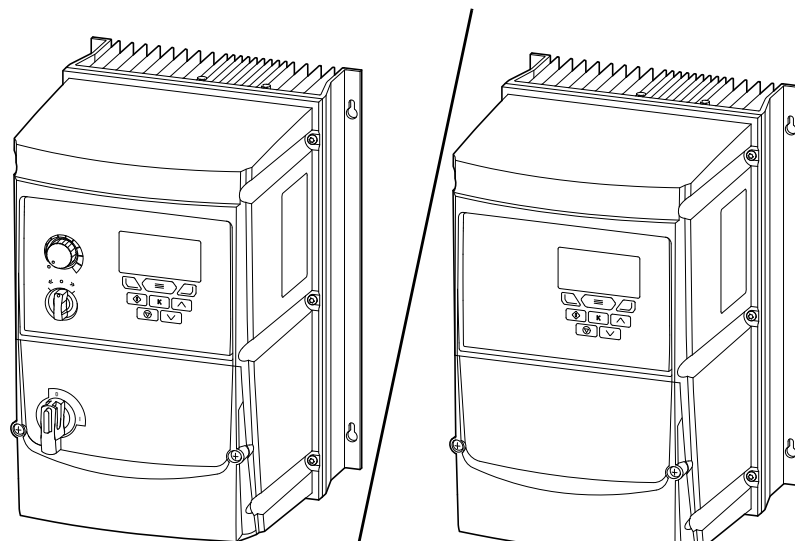

Eaton.com/documentation
MN040063... DA1



Eaton.com/EcoDesign-VFD
MZ040046EN

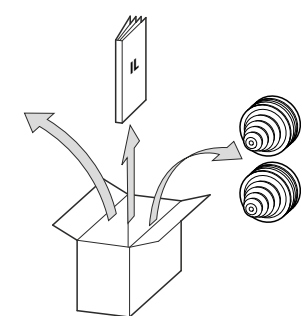

DA1-...-B6S0

6S = IP66, switched

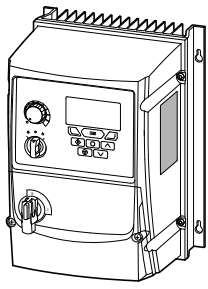

DA1-...-B660

66 = IP66

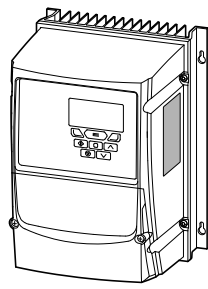

DA1-x y zzz F N-A 66 N

N = Basic device
 C = Coated printed circuit board
 O = Coated Board, Outdoor
 66 = IP66, NEMA 4x
 6S = IP66, NEMA 4x switched
 A = LED Display
 B = Graphical
 B = Brake chopper (DC+, BR)
 N = No Brake chopper
 F = EMC Filter (RFI)
 N = No EMC Filter

I_e
 2D2 = 2.2 A
 024 = 24 A

U_{LN} (Mains), 50/60 Hz
 2 = 230 V (200 - 240 V ± 10 %)
 4 = 400 V (380 - 480 V ± 10 %)
 5 = 500 V (500 - 600 V ± 10 %)

Mains \rightarrow Motor
 1 = 1 AC \rightarrow 3 AC
 3 = 3 AC \rightarrow 3 AC

Mains (TN, TT)

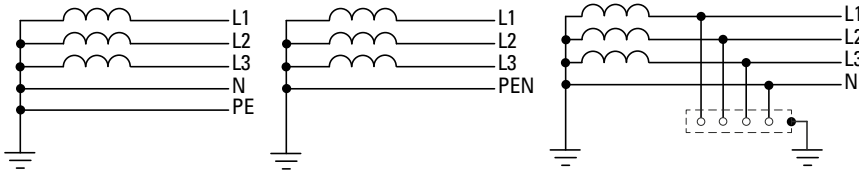

en Dimensions and weights
de Abmessungen und Gewichte
fr Encombrements et poids
es Dimensiones y pesos
it Dimensioni e pesi
zh 尺寸和重量
ru Размеры и вес

nl Afmetingen en gewichten
da Mål og vægt
el Διαστάσεις και βάρη
pt Medições e pesos
sv Dimensioner och vikter
fi Mitat ja painot
cs Rozměry a hmotnosti

et Mõõtmed ja kaalud
hu Méretek és Súly
lv Izmēri un svars
lt Matmenys ir svoriai
pl Wymiary i masy
sl Dimenzije in teže
sk Rozměry a hmotnosti

bg Размери и тегло
ro Dimensiuni și greutateți
hr Dimenzije i težina
tr Boyutlar ve ağırlıklar
sr Димензије и тежине
no Dimensjoner og vektor
uk Габаритні розміри й вага
ar الأبعاد والأوزان

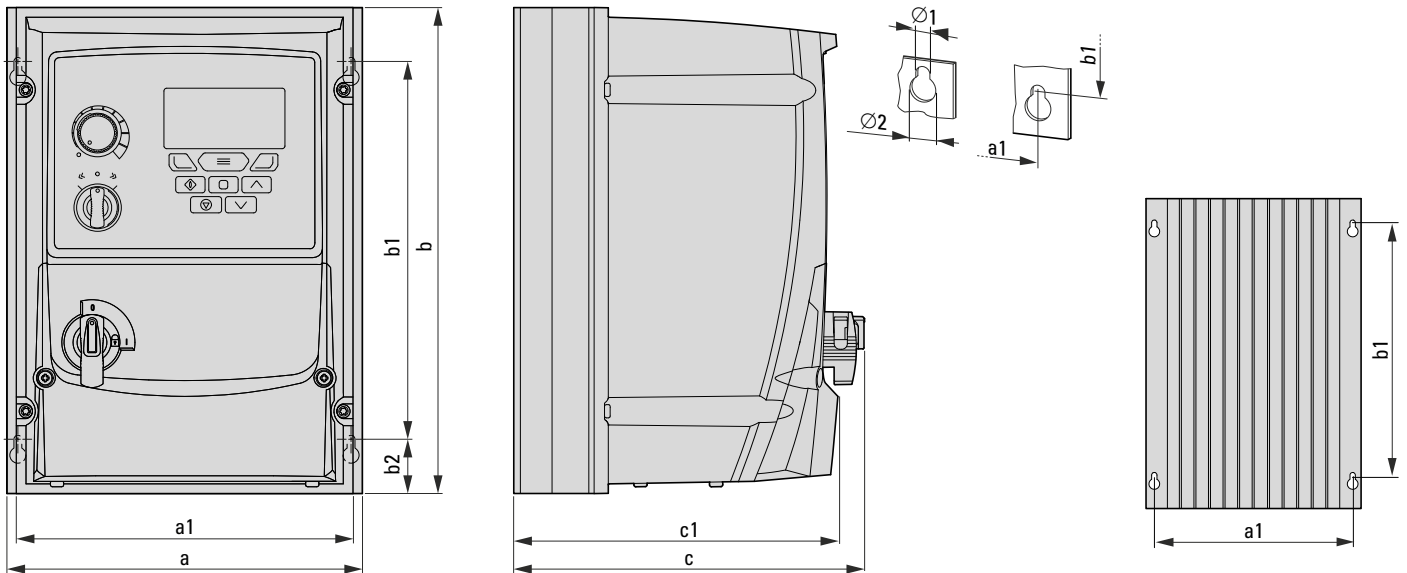

[mm (in)]

FS	a	a1	b	b1	b2	c	c1	Ø1	Ø2	 kg (lbs)
FS2	188 (7.4)	176 (6.93)	257 (10.13)	200 (7.88)	27 (1.06)	182 (7.17)	172 (6.78)	4.2 (0.17)	8.5 (0.33)	3.5 (7.72)
FS3	211 (8.31)	197 (7.76)	310 (12.21)	252 (9.93)	31 (1.22)	235 (9.26)	225 (8.87)	4.2 (0.17)	8.5 (0.33)	6.6 (14.55)
FS4	240 (9.45)	227 (8.94)	360 (14.18)	300 (11.82)	30 (1.18)	271 (10.68)	260 (10.24)	4.2 (0.17)	8.5 (0.33)	9.5 (20.95)

→ 1 inch = 25.4 mm
 1 mm = 0.0394 inch
 1 inch = 1"
 1 kg = 2.2046 lbs

12/24 IL040061ZU

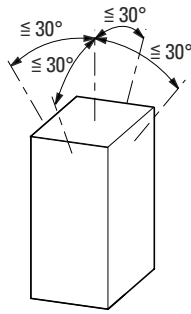
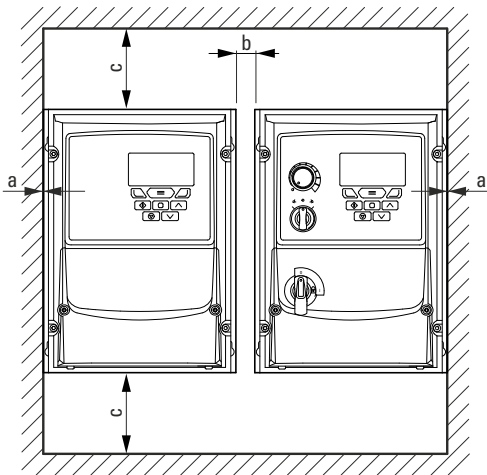

FS2, FS3, FS4 = 4 x M4
1 Nm (8.85 lb-in)

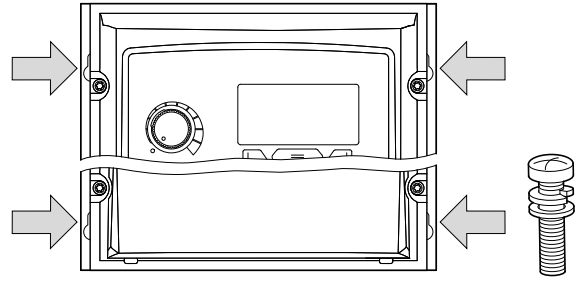

[mm (in)]

	a	b	c
FS2	0	12.0 (0.47)	200 (7.87)
FS3	0	13.0 (0.51)	200 (7.87)
FS4	0	42.5 (1.67)	200 (7.87)

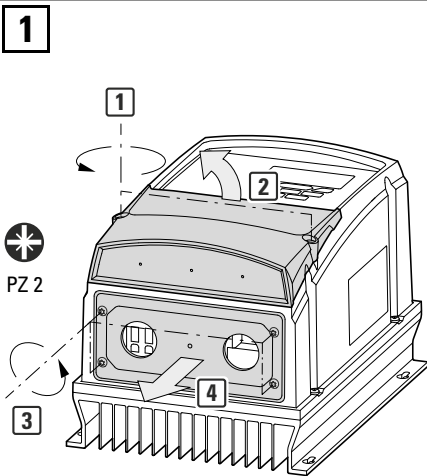

12/24 IL040061ZU

2a (en) optional – (de) optional – (fr) option – (ru) опция – (nl) optioneel – (da) valgfrit – (es) opcional – (it) opzionale – (zh) 可选 – (el) προαιρετικά – (pt) opcional – (sv) alternativ – (fi) valinnainen – (cs) volitelně – (et) lisavarustus – (hu) választható – (lv) pēc izvēles – (lt) pasirinktinai – (pl) opcjonalnie – (sl) opcijsko – (sk) voliteľné – (bg) опция – (ro) opțional – (hr) neobavezan – (tr) isteğe bağlı – (sr) опционо – (no) valgfritt – (uk) замовляється додатково – (ar) اختياري

2b (en) optional – (de) optional – (fr) option – (ru) опция – (nl) optioneel – (da) valgfrit – (es) opcional – (it) opzionale – (zh) 可选 – (el) προαιρετικά – (pt) opcional – (sv) alternativ – (fi) valinnainen – (cs) volitelně – (et) lisavarustus – (hu) választható – (lv) pēc izvēles – (lt) pasirinktinai – (pl) opcjonalnie – (sl) opcijsko – (sk) voliteľné – (bg) опция – (ro) opțional – (hr) neobavezan – (tr) isteğe bağlı – (sr) опционо – (no) valgfritt – (uk) замовляється додатково – (ar) اختياري

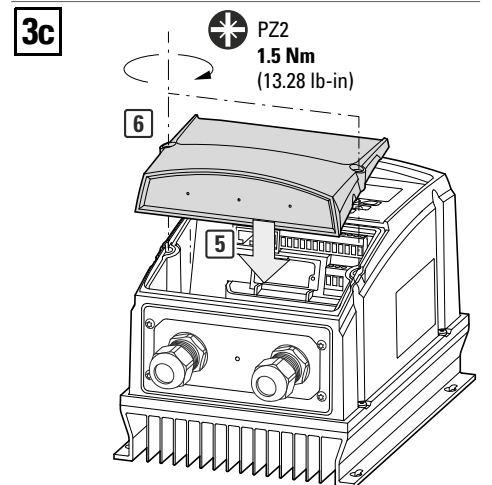
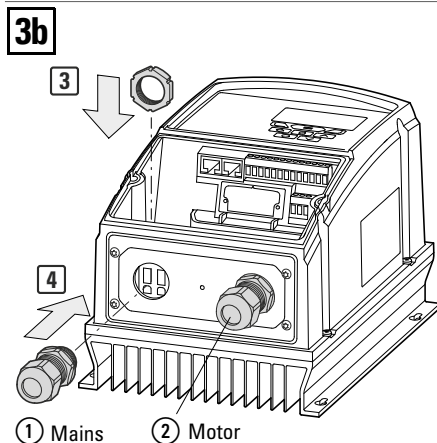
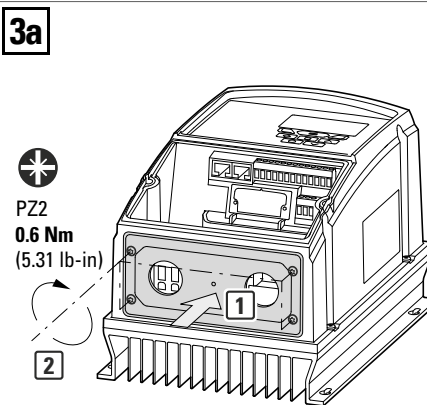
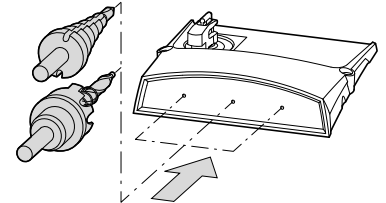
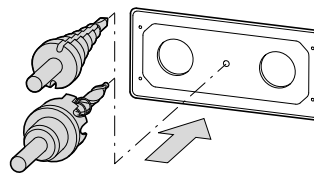

	FS	Ø mm (in)	PG	M
Control	FS2 FS3 FS4	2 x 20.4 (0.8)	2 x PG 13.5	2 x M20

	FS	Ø mm (in)	PG	M
Power	FS2 FS3 FS4	2 x 27 (1.06) 2 x 37 (1.46)	2 x PG 21 2 x PG 29	2 x M25/M32 2 x M40

① (en) Plastic – (de) Kunststoff – (fr) Matière isolante – (es) Plástico – (it) Plastica – (zh) 塑料 – (ru) пластмасса – (nl) Kunststof – (da) Kunststof – (el) Πλαστικό – (pt) Plástico – (sv) Plast – (fi) Muovi – (cs) Plast – (et) Plastmaterjal – (hu) Műanyag – (lv) Plastmasa – (lt) Plastik – (pl) Tworzywo sztuczne – (sl) Umetna masa – (sk) Umelá hmota – (bg) Пластмаса – (ro) Plastic – (hr) Plastika – (tr) Plastik – (sr) Пластика – (no) Plast – (uk) зПластик – (ar) بلاستيك

② (en) Metal – (de) Metall – (fr) Métal – (es) Metal – (it) Metallo – (zh) 金属 – (ru) металл – (nl) Metaal – (da) Metal – (el) Μέταλλο – (pt) Metal – (sv) Metall – (fi) Metall – (cs) Kov – (et) Metall – (hu) Fém – (lv) Metāls – (lt) Metalas – (pl) Metal – (sl) Kovina – (sk) Kov – (bg) Метал – (ro) Metal – (hr) Metal – (tr) Metal – (sr) Метал – (no) Metall – (uk) Метал – (ar) معدن

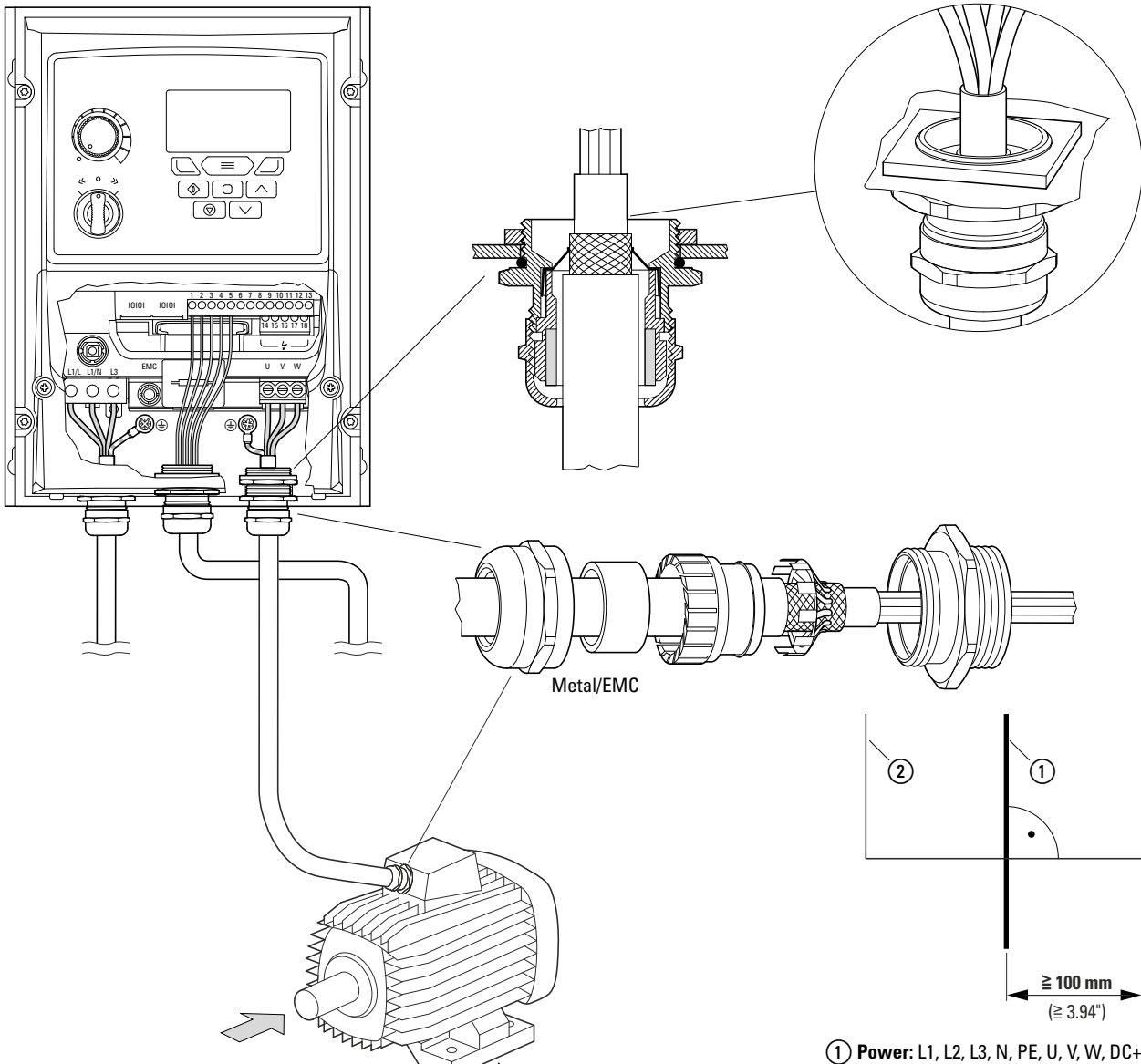

Metal/EMC

- ① Power: L1, L2, L3, N, PE, U, V, W, DC+, BR
- ② Control: 1, 2, ... 11, Modbus, CANopen

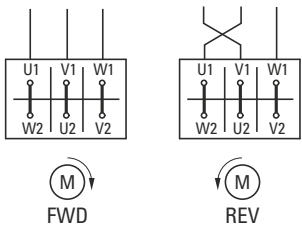

230/400 V	3.2/1.9 A
0,75 KW	cosφ 0.79
1410 mi n ⁻¹	50 Hz

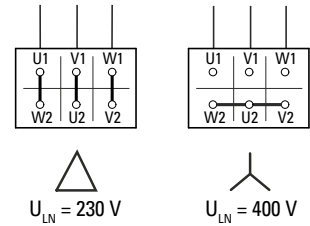

12/24 IL040061ZU

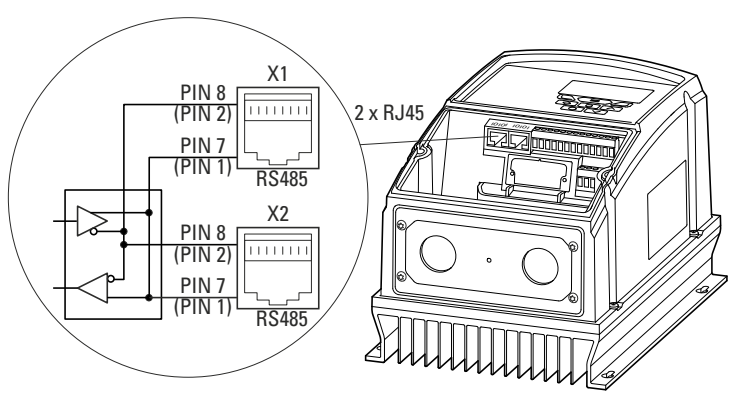
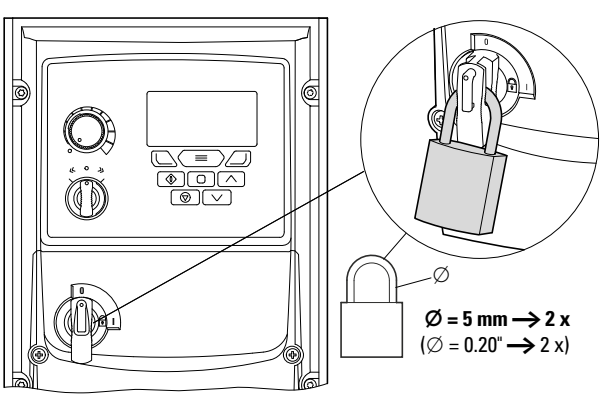

PIN 1	CANopen -
PIN 2	CANopen +
PIN 7	Modbus RTU -
PIN 8	Modbus RTU +

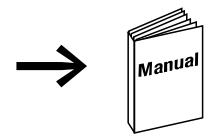



(en) **CAUTION**

Connect only in voltage-free state!

(de) **VORSICHT**

Nur im spannungsfreien Zustand anschließen!

(fr) **ATTENTION**

Raccordez l'appareil uniquement hors tension !

(es) **ATENCIÓN**

¡Conectar únicamente en estado sin tensión!

(it) **ATTENZIONE**

Collegare solo in assenza di tensione!

(zh) **注意**

必须在断电状态下进行连接!

(ru) **ВНИМАНИЕ**

Подключать только в обесточенном состоянии!

(nl) **VOORZICHTIG**

Alleen in spanningsloze toestand aansluiten!

(da) **FORSIGTIG**

Må kun tilsluttes i spændingsfri tilstand!

(el) **ΠΡΟΣΟΧΗ**

Συνδέστε μόνο όταν δεν επικρατεί τάση!

(pt) **CUIDADO**

Ligar apenas com a tensão desligada!

(sv) **OBSERVERA**

Får endast anslutas i spänningsfritt tillstånd!

(fi) **HUOMIO**

Kytke vain jännitteettömässä tilassa!

(cs) **UPOZORNĚNÍ**

Připojujte jen při zcela odpojeném napájení!

(et) **ETTEVAATUST**

Ühendada ainult pingevabas olekus!

(hu) **VIGYÁZAT**

Csak feszültségmentes állapotban csatlakoztassa!

(lv) **UZMANĪBU**

Pieslēgt tikai tad, kad nenotiek sprieguma padeve!

(lt) **PERSPĖJIMAS**

Prijungti tik tada, kai išjungta įtampa!

(pl) **PRZESTROGA**

Podłączać zawsze po uprzednim odłączeniu od zasilania elektrycznego!

(sl) **POZOR**

Napravo priključite le, ko ni pod napetostjo!

(sk) **UPOZORNENIE**

Napájať len v stave bez napätia!

(bg) **ВНИМАНИЕ**

Свързвайте само, когато уреда не е под напрежение!

(ro) **ATENȚIE**

Conectați doar când aparatul nu se află sub tensiune!

(hr) **PAZNJA**

Priključujte samo u beznaponskom stanju!

(tr) **DİKKAT**

Sadece gerilim sıfırken bağlayın!

(sr) **ОПРЕЗ**

Прикључујте само у стању без напона!

(no) **FORSIKTIG**

Tilkoble bare i spenningsfri tilstand!

(uk) **УВАГА**

Підключати лише за відсутності напруги!

(ar) **انتباه**

التوصيل فقط في حال عدم الفولتية!

Mains 1 ~

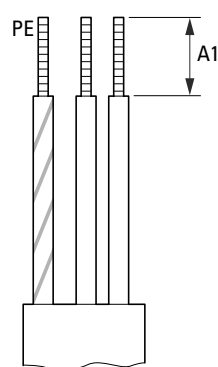

Mains 3 ~

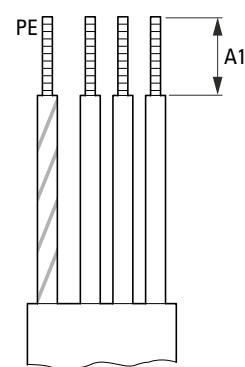

Motor

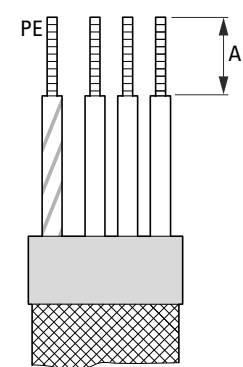

Brake Resistor

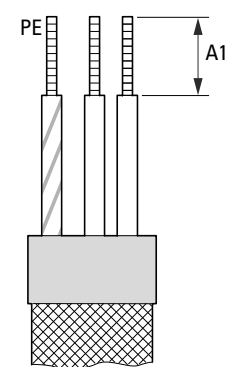

FS2, FS3, FS4
A1 = 10 mm (0.39")

12/24 IL040061ZU

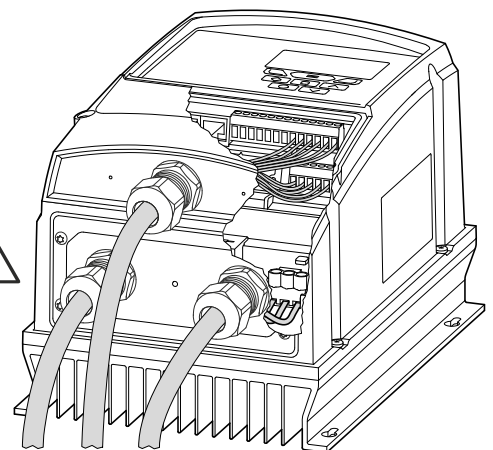
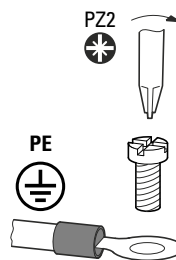
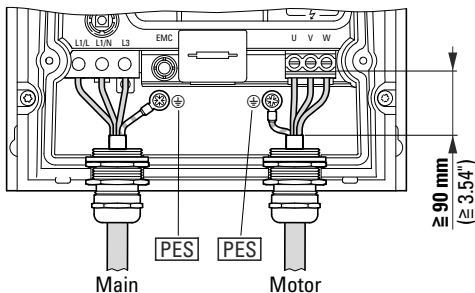

		DA1-...-B660	DA1-...-B6S60
Mains	FS2, FS3	1 Nm (8.85 lb-in)	0.8 Nm (7.08 lb-in)
	FS4	2.2 Nm (19.47 lb-in)	2 Nm (17.7 lb-in)
Motor, Brake Resistor	FS2, FS3	1 Nm (8.85 lb-in)	1 Nm (8.85 lb-in)
	FS4	2.2 Nm (19.47 lb-in)	2.2 Nm (19.47 lb-in)

DA1-12...-x66x

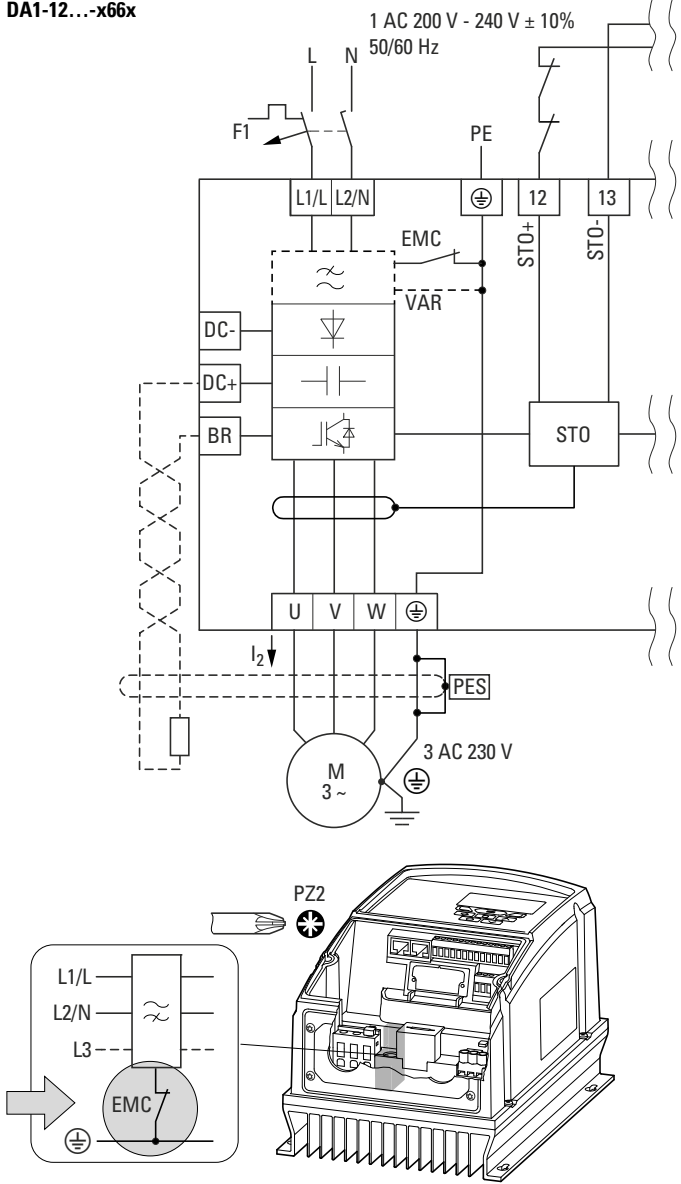

**DA1-32...-x66x,
DA1-34...-x66x
DA1-35...-x66x**

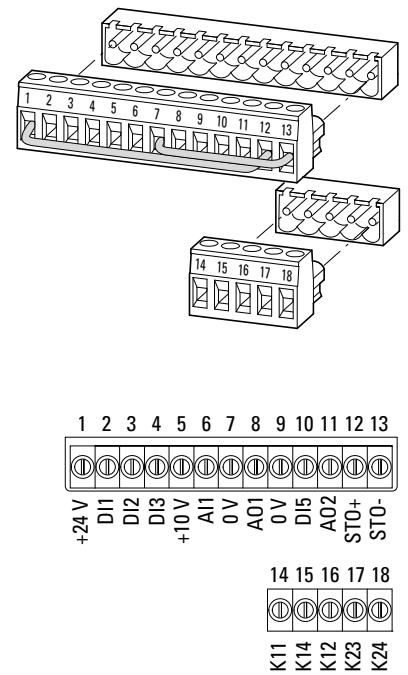
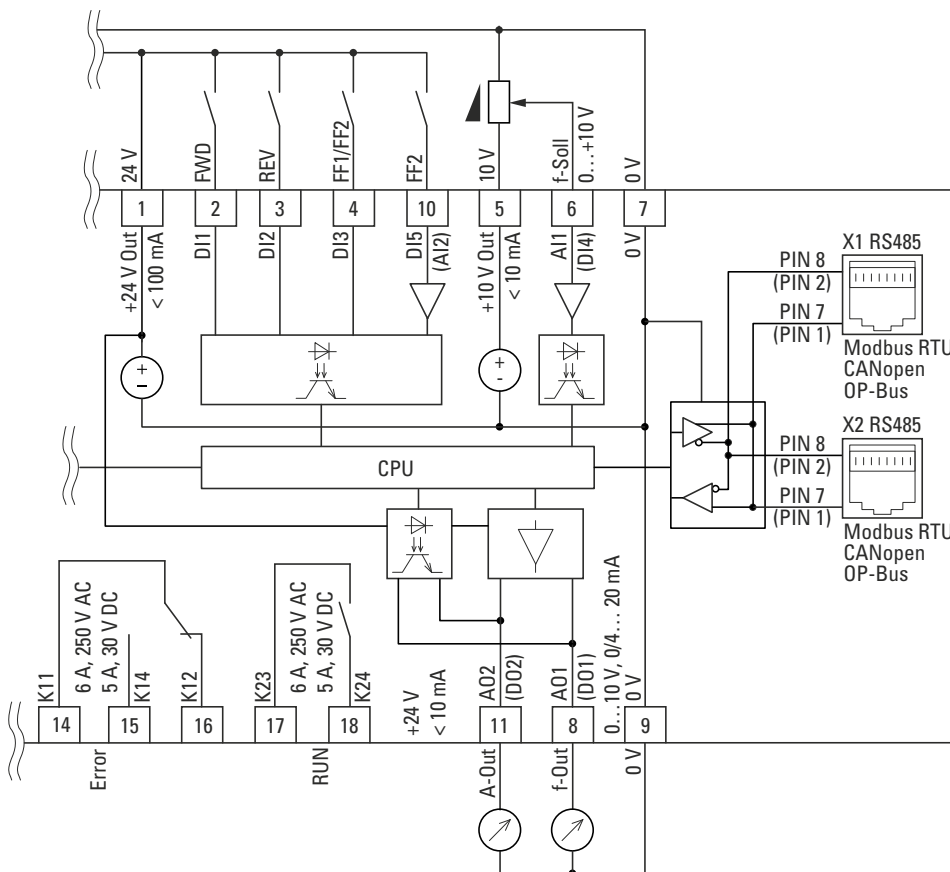
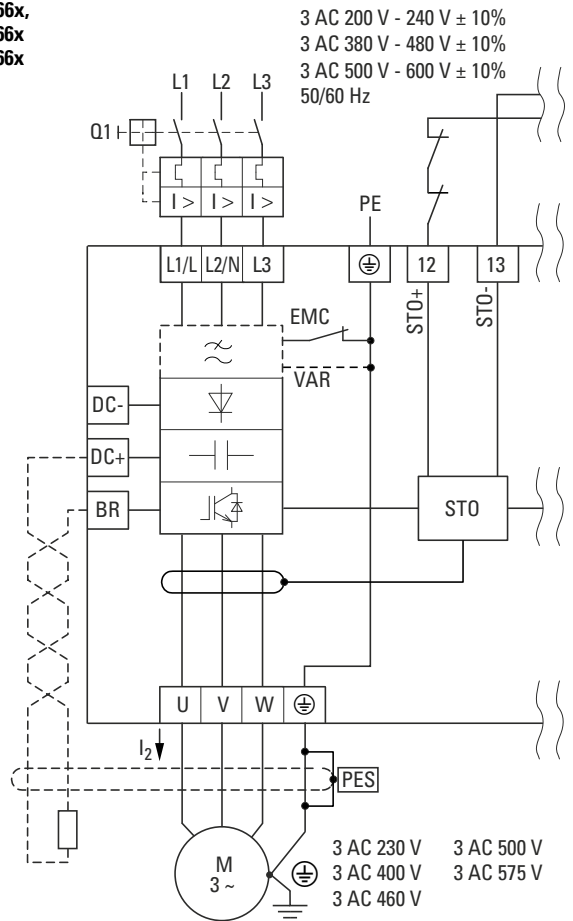

12/24 IL040061ZU

DA1-12...-x6Sx

1 AC 200 V - 240 V ± 10%
50/60 Hz

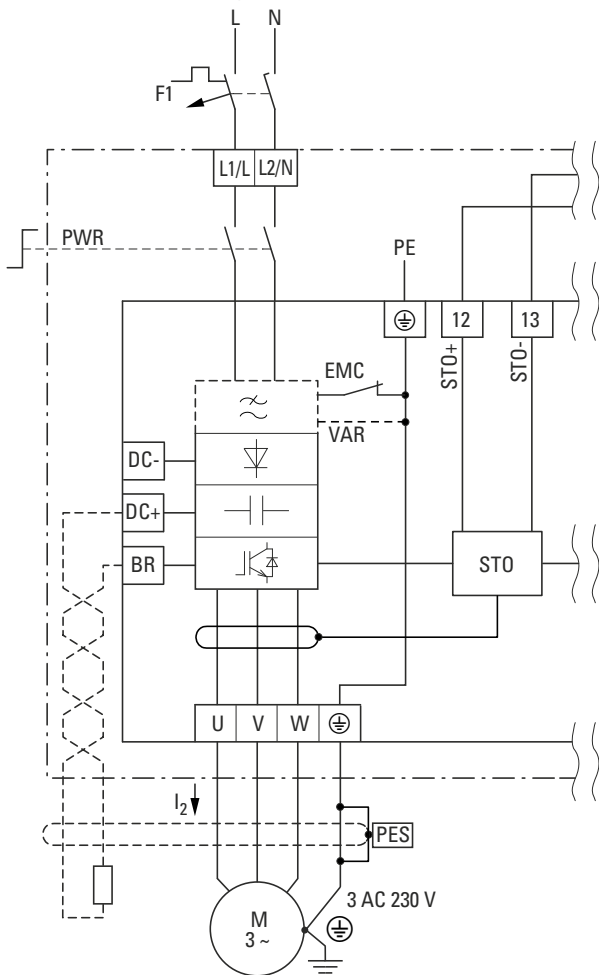

DA1-32...-x6Sx
DA1-34...-x6Sx
DA1-35...-x66x

3 AC 200 V - 240 V ± 10%
3 AC 380 V - 480 V ± 10%
3 AC 500 V - 600 V ± 10%
50/60 Hz

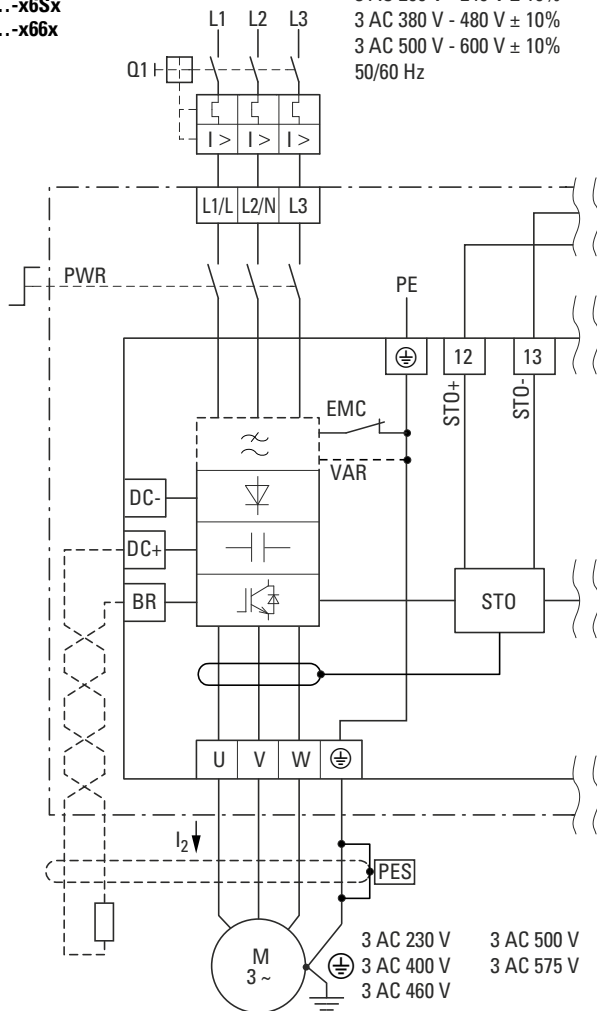

12/24 IL040061ZU

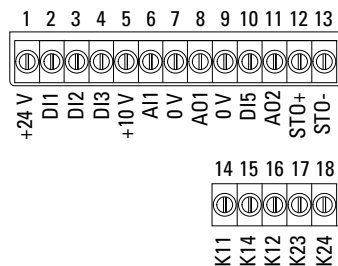
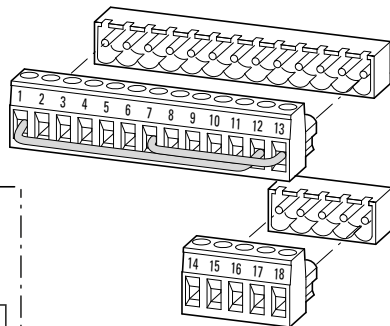
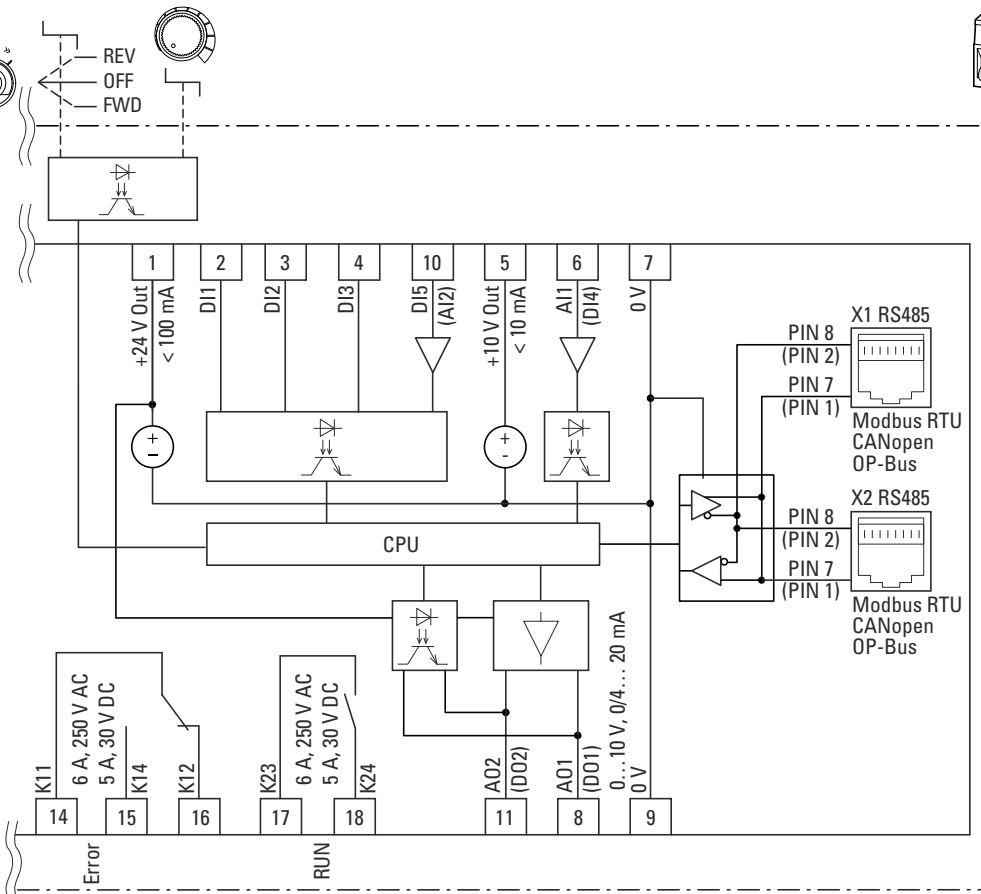
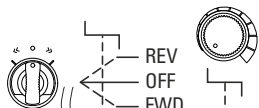

	Frame Size	I _{LN} A	F1/Q1 MCB (type B) A	Mains		I _e A	Motor		P		R _B brake resistor		
				mm ²	AWG		mm ²	AWG	kW	HP	Ω	mm ²	AWG
DA1-124D3...	2	4.3	16 (15)	2 x 8	2 x 8	8.6	3 x 8	3 x 8	0.75	1	100	8	8
DA1-127D0...	2	7	16 (17.5)	2 x 8	2 x 8	12.9	3 x 8	3 x 8	1.5	2	50	8	8
DA1-12011...	2	10.5	25 (25)	2 x 8	2 x 8	19.2	3 x 8	3 x 8	2.2	3	35	8	8
DA1-324D3...	2	4.3	10 (10)	3 x 8	3 x 8	5.7	3 x 8	3 x 8	0.75	1	100	8	8
DA1-327D0...	2	7	16 (15)	3 x 8	3 x 8	10.5	3 x 8	3 x 8	1.5	2	50	8	8
DA1-32011...	2	10.5	16 (17.5)	3 x 8	3 x 8	13.2	3 x 8	3 x 8	2.2	3	35	8	8
DA1-32018...	3	18	32 (30)	3 x 8	3 x 8	20.9	3 x 8	3 x 8	4	5	20	8	8
DA1-32024...	3	24	32 (35)	3 x 8	3 x 8	26.4	3 x 8	3 x 8	5.5	7.5	20	8	8
DA1-32030...	4	30	40 (40)	3 x 16	3 x 5	33.3	3 x 16	3 x 5	7.5	10	22	16	5
DA1-32046...	4	46	63 (70)	3 x 16	3 x 5	50.1	3 x 16	3 x 5	11	15	22	16	5
DA1-342D2...	2	2.2	6 (6)	3 x 8	3 x 8	3.5	3 x 8	3 x 8	0.75	1	400	8	8
DA1-344D1...	2	4.1	10 (10)	3 x 8	3 x 8	5.6	3 x 8	3 x 8	1.5	2	200	8	8
DA1-345D8...	2	5.8	10 (10)	3 x 8	3 x 8	7.5	3 x 8	3 x 8	2.2	3	150	8	8
DA1-349D5...	2	9.5	16 (15)	3 x 8	3 x 8	11.5	3 x 8	3 x 8	4	5	100	8	8
DA1-34014...	3	14	25 (25)	3 x 8	3 x 8	17.2	3 x 8	3 x 8	5.5	7.5	75	8	8
DA1-34018...	3	18	32 (30)	3 x 8	3 x 8	21.8	3 x 8	3 x 8	7.5	10	50	8	8
DA1-34024...	3	24	40 (35)	3 x 8	3 x 8	27.5	3 x 8	3 x 8	11	15	40	8	8
DA1-34030...	4	30	50 (45)	3 x 16	3 x 5	34.2	3 x 16	3 x 5	15	20	22	16	5
DA1-34039...	4	39	63 (60)	3 x 16	3 x 5	44.1	3 x 16	3 x 5	18.5	25	22	16	5
DA1-34046...	4	46	63 (70)	3 x 16	3 x 5	51.9	3 x 16	3 x 5	22	30	22	16	5
DA1-352D1...	2	2.1	10 (6)	3 x 8	3 x 8	2.5	3 x 8	3 x 8	0.75	1	600	8	8
DA1-353D1...	2	3.1	10 (6)	3 x 8	3 x 8	3.7	3 x 8	3 x 8	1.5	2	300	8	8
DA1-354D1...	2	4.1	10 (10)	3 x 8	3 x 8	4.9	3 x 8	3 x 8	2.2	3	200	8	8
DA1-356D5...	2	6.5	10 (10)	3 x 8	3 x 8	7.8	3 x 8	3 x 8	4	5	150	8	8
DA1-359D0...	2	9	16 (15)	3 x 8	3 x 8	10.8	3 x 8	3 x 8	5.5	7.5	100	8	8
DA1-35012...	3	12	16 (20)	3 x 8	3 x 8	14.4	3 x 8	3 x 8	7.5	10	80	8	8
DA1-35017...	3	17	25 (30)	3 x 8	3 x 8	20.6	3 x 8	3 x 8	11	15	50	8	8
DA1-35022...	3	22	32 (35)	3 x 8	3 x 8	26.7	3 x 8	3 x 8	15	20	33	8	8
DA1-35028...	4	28	40 (45)	3 x 16	3 x 5	34	3 x 16	3 x 5	18.5	25	33	16	5
DA1-35034...	4	34	50 (60)	3 x 16	3 x 5	41.2	3 x 16	3 x 5	22	30	22	16	5
DA1-35043...	4	43	63 (70)	3 x 16	3 x 5	49.5	3 x 16	3 x 5	30	40	22	16	5

mm ²	mm ²	AWG	mm	in	M2.5	lb-in	mm
0.2 - 2.5	0.2 - 1.5	24 - 12	5	0.2	0.5	4.43	0.4 x 2.5

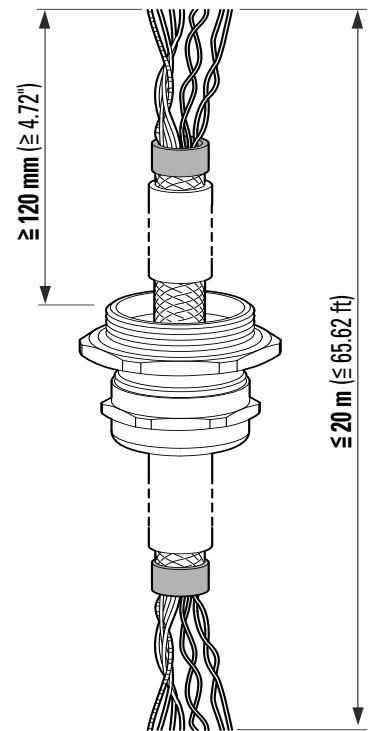
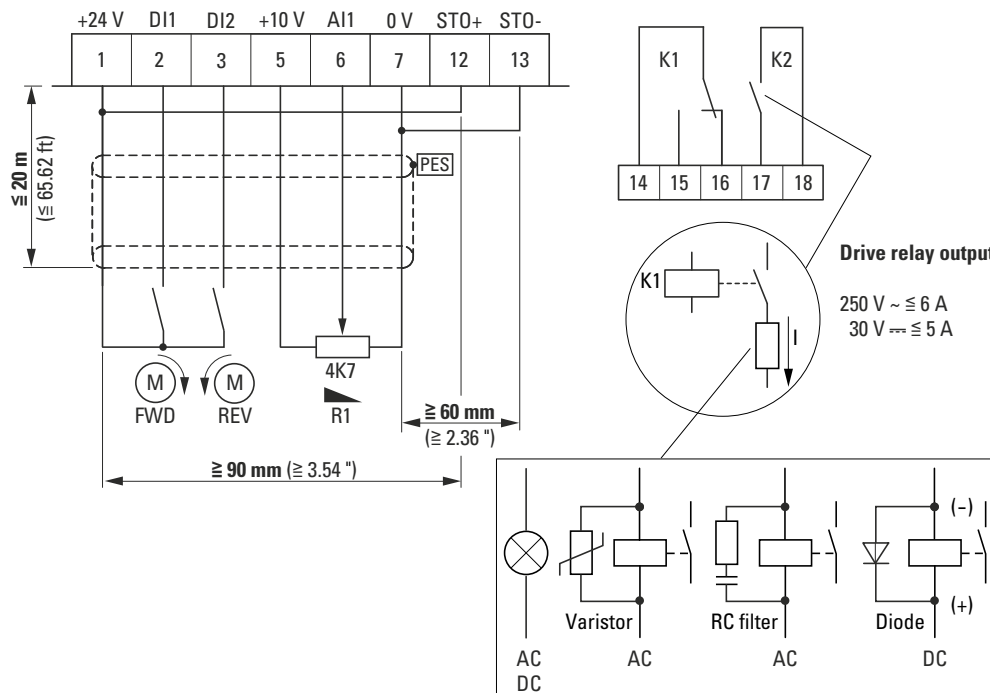

12/24 IL040061ZU

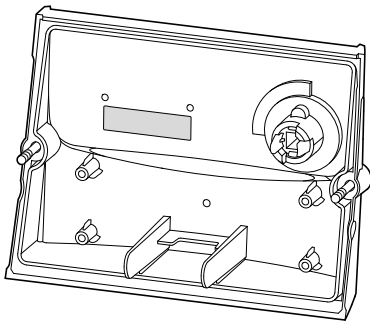

Further information available from
Eaton.com/documentation

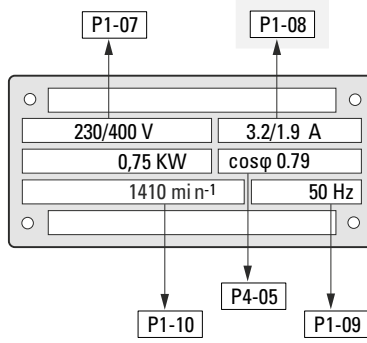

Stop [OK] > 1 s

P 1-01 [▲] / [▼]

P 1-08 [OK]

A 22 [▼] 3x

A 19 [OK] > 1 s

Stop

DA1-...-B6x0

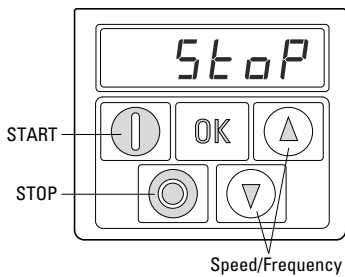

DA1-...-B6Sx

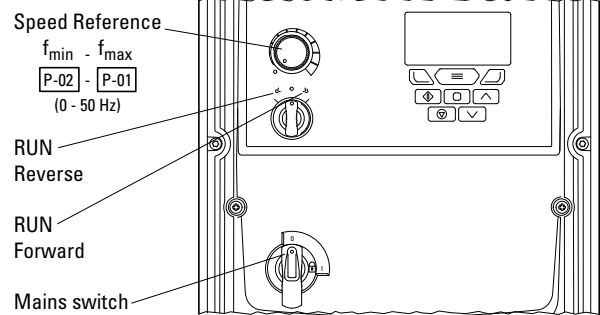

12/24 IL040061ZU

STOP [OK] > 1 s

P 1-01 [▲] / [▼]

P 1-12 [OK]

0 [▲] 1x

1 [OK] > 1 s

STOP [OK]

H 0.0 [1] [2] [START Motor] [▲] n x [Motor Start FWD]

H 34.5 (Example)

H 34.5 [OK] A 0.4 [OK] P 0.21
Herz Ampere kW

[OK] or [1] [2] ⇒ STOP STOP Motor

Stop [REV] [FWD] n x [Motor Start FWD]

or

Stop [REV] [FWD] n x [Motor Start REV]

H 8.0 [REV] [FWD] H 50.0

H 34.5 (Example)

H 34.5 [OK] A 0.4 [OK] H 34.5
Herz Ampere Herz

[REV] [FWD] 0 ⇒ STOP STOP Motor

STO (Safe Torque Off)

- (en) Shielded cable [PES] routed in an inherently short-circuit-proof and ground-fault-proof manner
- (de) Abgeschirmtes Kabel [PES] erd- und kurzschlussicher verlegen (eks)
- (fr) Câble blindé [PES] à poser avec protection contre courts-circuits/défauts à la terre
- (es) Tender el cable [PES] apantallado con seguridad de puesta a tierra y cortocircuito.
- (it) Posare il cavo [PES] schermato collegato a terra e protetto contro il cortocircuito
- (zh) 铺设接地防短路屏蔽电缆 [PES]
- (ru) Экранированный кабель [PES] прокладывается с защитой от замыкания на землю и коротких замыканий.
- (nl) Afgeschermde kabel [PES] geaard en kortsluitveilig installeren
- (da) Læg det afskærmede kabel [PES] jord- og kortslutningssikkert.
- (el) Τοποθετήστε το θωρακισμένο [PES] ο καλώδιο κατά τρόπον ώστε να είναι ασφαλές από βραχυκύκλωμα γείωσης και βραχυκύκλωμα.
- (pt) Dispor o cabo [PES] blindado com ligação à terra e protegido contra curto-circuito
- (sv) Dra den skärmede kabeln [PES] jordfels- och kortslutningssäkert.
- (fi) Sijoita suojaattu kaapeli [PES] maa- ja oikosulkusuojatusti (mos).
- (cs) Stíněný kabel [PES] položte tak, aby byl bezpečný proti uzemnění a zkratu (buz).
- (et) Paigaldage varjestatud kaabel [PES] maandus- ja lühiskaitstult (mlk).
- (hu) Árnyékolt kábelt [PES] földelvé és rövidzármntesen kell lefektetni.

- (lv) Izvilkt ekranētu kabeļi [PES], kas ir aizsargāts pret zemslēgumiem un īsslēgumiem.
- (lt) Ekranuotą kabeļį [PES] nutieskite apsaugotą nuo žemėjimo ir trumpojo jungimo.
- (pl) Kabel ekranowany [PES] ułożyć z zabezpieczeniem przed zwarciem i zwarciem doziemnym.
- (sl) Izoliran kabel [PES] speljite zavarovano pred zemljskim in kratkim stikom.
- (sk) Uložte tieněný kábel [PES], odolný voči skratu a náhodnému uzemneniu.
- (bg) Положете екраниран кабел [PES] и го заземете срещу късо съединение.
- (ro) Pozați cablul [PES] ecranat astfel încât să fie asigurată protecția la scurtcircuit și scurgeri la pământ.
- (hr) Zakrijljeni kabel [PES] postavite tako da bude zaštićen od uzemljenja i kratkog spoja.
- (tr) Korumalı kablo [PES], dođal olarak kısa devre ve topraklama arızası korumalı olarak yönlendirilir
- (sr) Oklopljeni kabl [PES] vođen na način otporan na kratke spojeve i kvarove uzemljenja
- (no) Panserkabel [PES] lagt på en måte som i seg selv er sikret mot kortslutning og jordfeil
- (uk) Екранований кабель [PES], прокладений з дотриманням правил захисту від коротких замикань і замикань на землю.
- (ar) في الأساس بطريقة تحمي من القصر ؟ تم توجه الكابل المحمي ومن الخطأ الأرضي

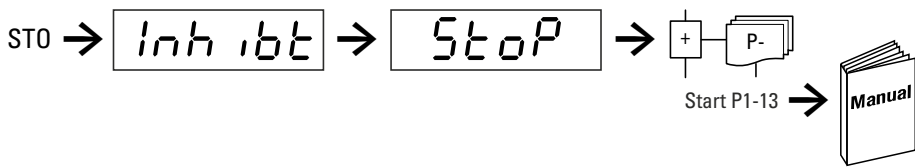
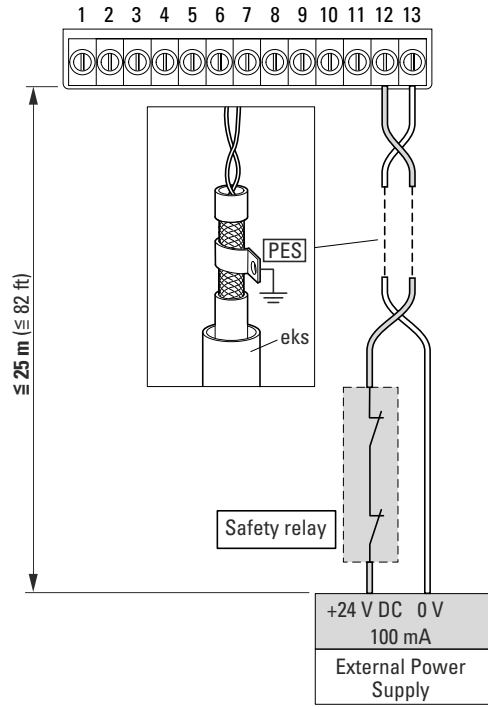
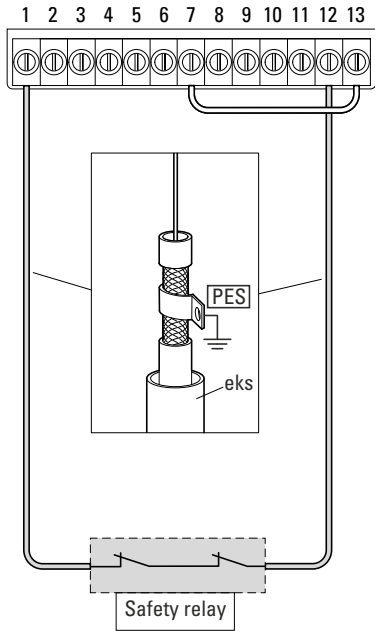

(en) Thermistor	(it) Termistore	(da) Thermistor	(fi) Termistori	(lv) Termistors	(sk) Termistor	(tr) Termistör
(de) Thermistor	(zh) 热敏电阻	(el) Θερμίστορ	(cs) Termistor	(lt) Termistorius	(bg) Термистор	(sr) Термистор
(fr) Thermistance	(ru) Термистор	(pt) Thermistance	(et) Termistor	(pl) Termistor	(ro) Termistor	(no) Termistor
(es) Termistor	(nl) Thermistor	(sv) Termistor	(hu) Termisztor	(sl) Termistor	(hr) Termistor	(uk) Термістор
						(ar) المقاوم الحراري

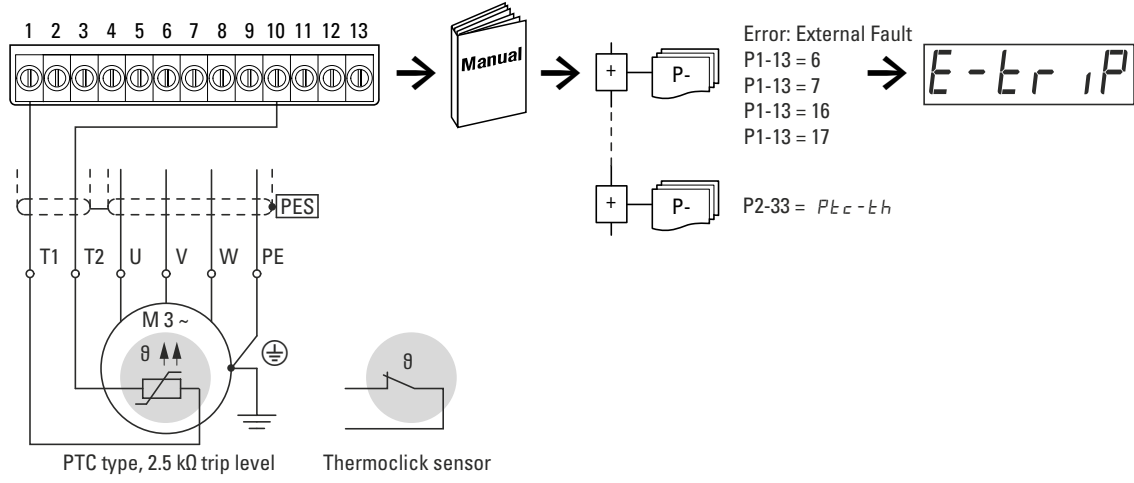

**(en) CAUTION**

In the territory of the EU Directive the frequency-controlled devices and their accessories must be taken into operation only when the machine has been determined to fulfill the protection requirements of Machinery Directive 2006/42/EC. Ensure EMC-compliant installation. Lay control and communication cables spatially separated from the motor cable. Ensure a large contact area connection between cable screen and PE.

(de) VORSICHT

Im Geltungsbereich der EG-Richtlinien dürfen die frequenzgesteuerten Geräte und deren Zubehör nur dann in Betrieb genommen werden, wenn festgestellt wird, dass die Maschine die Schutzanforderungen der Maschinenrichtlinie 2006/42/EG erfüllt. EMV-gerechter Aufbau. Steuer- und Netzleitungen räumlich getrennt von der Motorleitung verlegen. Leitungsschirm großflächig mit PE verbinden.

(fr) ATTENTION

En application des directives européennes, les convertisseurs de fréquence et leurs accessoires ne doivent être mis en service que s'il a été vérifié que la machine répond aux exigences de la directive machines 2006/42/CE. Montage conforme aux règles de la CEM. Eloigner les câbles de commande et de réseau des câbles puissance. Relier le blindage au PE en assurant de grandes surfaces de contact.

(es) ATENCIÓN

En el campo de aplicación de la normativa CE, los dispositivos controlados por frecuencia y sus correspondientes accesorios sólo deberán ponerse en marcha cuando se asegure que la máquina cumple con las exigencias de seguridad de la normativa de máquinas 2006/42/CE. El montaje debe cumplir CEM. Los cables de mando y de conexión a red se deben instalar independientemente del cable de conexión al motor. El cable apantallado se debe conectar a masa utilizando una amplia superficie de contacto.

(it) ATTENZIONE

Nel campo di validità delle direttive CE, gli apparecchi a controllo di frequenza e i loro accessori possono essere messi in esercizio soltanto se si verifica che la macchina soddisfa i requisiti di sicurezza della direttiva macchine 2006/42/CE. Montaggio secondo CEM. Disporre i cavi comandi e di alimentazione separati dal cavo del motore. Collegare lo schermo del cavo con PE con un'ampia superficie.

(zh) 注意

根据欧盟设备一致性规范，安装频率控制设备及其配件时，应确保设备满足机器规范 2006/42/EG 中关于设备保护的要求。
按照电磁兼容规范正确安装。应将控制电缆和电源电缆与机电电缆分开。
大面积采用 PE 包裹电缆。

(ru) ВНИМАНИЕ

В сфере действия директив ЕС устройства с частотным управлением и их оснащение должны вводиться в эксплуатацию только в том случае, если установлено, что данное оборудование соответствует требованиям по защите Директивы о машинном оборудовании 2006/42/ЕС. Сборка соответственно электромагнитной совместимости. Линии управления и электросети прокладывать в пространственном отношении отдельно от линии двигателя. силовой экран соединять с PE по большой площади.

(nl) VOORZICHTIG

Binnen het geldigheidsgebied van de EC-richtlijnen mogen de frequentieregelder apparaten en de toebehoren daarvan alleen in bedrijf worden genomen, wanneer wordt vastgesteld, dat de machine aan de veiligheidsvoorschriften van de machinerichtlijn 2006/42/EG voldoet. EMC-conforme constructie. Besturings- en netkabels ruimtelijk gescheiden van de motorkabel leggen. Kabelafscherming over groot oppervlak met PE verbinden.

(da) FORSIGTIG

I det område, hvor EF-direktiverne er gældende, må det frekvensstyrede udstyr og dets tilbehør kun tages i anvendelse, hvis det konstateres, at maskinen opfylder beskyttelseskravene i maskindirektivet 2006/42/EF. EMC-korrekt installation. Træk styre- og netledninger rumligt adskilt fra motorledningen. Sørg for en stor kontaktoverflade mellem ledningsafskærmning og PE.

(el) ΠΡΟΣΟΧΗ

Στο πεδίο εφαρμογής των οδηγιών της ΕΚ, οι ελεγχόμενες μέσω συχνότητας συσκευές και τα παρελκόμενά τους επιτρέπεται να τίθενται σε λειτουργία μόνο εφόσον διαπιστωθεί ότι το μηχάνημα πληροί τις απαιτήσεις προστασίας της οδηγίας της ΕΚ για τα μηχανήματα 2006/42/ΕΚ. Κατασκευή σύμφωνα με τις απαιτήσεις ΗΜΣ. Εγκαθιστάτε τους αγωγούς ελέγχου και δικτύου ανεξάρτητα από τον αγωγό του κινητήρα. Συνδέετε τη θωράκιση των αγωγών σε μεγάλη επιφάνεια με τη γείωση.

(pt) CUIDADO

No âmbito das directivas da CE, os aparelhos comandados por frequência e os respectivos acessórios só podem ser postos em operação se for comprovado que a máquina atende às exigências de protecção da directiva de máquinas 2006/42/CE. Estrutura com compatibilidade electromagnética. Dispor os fios de comando e de rede separados do fio do motor. Ligar uma área grande da blindagem do cabo com o PE.

(sv) OBSERVERA

I giltighetsområdet för EG-direktiven får de frekvensstyrda apparaterna och deras tillbehör endast tagas i drift när man fastställt att maskinen uppfyller skyddskraven i maskindirektiv 2006/42/EG. EMC-anpassad uppbyggnad. Styre- och nätledningar dras avskilda från motorledningarna. Förbind ledningsskärm över ett brett område med PE.

(fi) HUOMIO

EU-direktiivin voimassaoloalueella taajuusohjatut laitteet ja niiden varusteet saa ottaa käyttöön vain silloin, kun todetaan, että kone täyttää konedirektiivin 2006/42/EY suojausvaatimukset. EMC-mukainen rakenne. Ohjaus- ja verkkojohdot on asennettava tilalotteisesti erotettuina. Johdonsuoja on liitettävä laajasti maadoitukseen .

(cs) UPOZORNĚNÍ

V rozsahu platnosti směrnice ES smí být frekvenčně řízené přístroje a jejich příslušenství uvedeny do provozu jedně tehdy, pokud je zjištěno, že stroj splňuje požadavky ochrany stanovené směrnici 2006/42/ES o strojních zařízeních. Nástavba odpovídající směrnici EMC. Řídící a síťová vedení pokládejte prostorově oddělená od vedení motoru. Stínění vedení spojte velkoplošně s PE.

(et) ETTEVAATUST

EU-direktiivi kehtivuspiirkonnas võib sagedusjuhitavaid seadmeid ja nende lisaseadmeid kasutusse võtta ainult siis, kui on kindlaks tehtud, et masin vastab masinadirektiivi 2006/42/EÜ kaitsenõuetele. Elektromagnetilisele ühilduvusele vastav ehitus. Juhtimis- ja võrgukaablid paigaldada mootori toitekaablist ruumiliselt eraldatuna. Kaabli kaitsekraan ühendada ulatuslikult talitlusmaandusega.

(hu) VIGYÁZAT

Az EK irányelvek hatályosságai területén a frekvenciavezérelt készülékeket és azok tartozékait csak akkor szabad üzembe helyezni, ha megállapítást nyert, hogy a gép megfelel a gépek biztonságáról szóló, 2006/42/EK számú irányelv biztonsági követelményeinek. Elektromágnesesen összeférhető kivitelű biztosítson. A motorvezetékektől térben elkülönítve vezesse vezérlő és hálózati vezetékeket. Nagy felületen csatlakoztassa a védőföldeléshez a vezetékárnyékolást.

(lv) UZMANĪBU

Valstis, kurās ir spēkā EK direktīvas, ierīcu ar frekvenču vadību un to piederumu ekspluatāciju drīkst sākt tikai tad, ja ir konstatēta iekārtas atbilstība Mašīnu direktīvā 2006/42/EK ietvertajām aizsardzības prasībām. EMS atbilstoša uzbūve. Vadības un tīkla kabelus izvietot atsevišķi no motora kabēļiem. Vada ekrānu plašā virsmā savienot ar PE.

(lt) PERSPĖJIMAS

EB direktyvų taikymo srityje dažniniu būdu valdomos įrenginius ir jų priedus leidžiama pradėti naudoti tik tada, kai nustatoma, kad įrenginys atitinka Mašinų direktyvos 2006/42/EB keliamus apsaugos reikalavimus. Montażas turi atitikti EMS reikalavimus. Valdymo ir duomenų tinklo kabelius išdėstyti atokiai nuo variklio kabelio. Kabelio ekraną dideliu paviršiumi sujungti su žeminiu.

(pl) PRZESTROGA

Na obszarze obowiązywania dyrektyw WE urzędzenia sterowane częstotliwościowo wolno wprowadzać do eksploatacji tylko wtedy, gdy zostanie stwierdzone, że maszyna spełnia wymagania ochronne dyrektywy maszynowej 2006/42/WE. Konstrukcja zgodna z dyrektywą w sprawie kompatybilności elektromagnetycznej (EMC). Przewody sterowania i zasilania elektrycznego należy układać oddzielnie od przewodu silnika. Ekranowanie połączyć z przewodem uziemiającym na większej powierzchni.

(sl) POZOR

Na območju veljavnosti direktiv ES je zagon frekvenčno krmiljenih naprav in njihovega pribora dovoljen le tedaj, ko je bilo ugotovljeno, da stroj ustreza varnostnim zahtevam Direktive o strojih 2006/42/ES. Montaža v skladu z EMZ. Krmilne in omrežne vodnike napeljite ločeno od vodnikov motorja. Oklep vodnika na veliki površini povežite z zaščitnim vodnikom.

(sk) UPOZORNENIE

V krajinách, ktoré spadajú pod pôsobnosť smerníc ES smú byť rádiovo ovládané zariadenia a ich príslušenstvo uvedené do prevádzky len ak je zabezpečené, že stroj spĺňa ochranné ustanovenia smernice č. 2006/42/ESS o strojových zariadeniach. Montáž v súlade s požiadavkami elektromagnetickej kompatibility. Ovládacie a sieťové vedenia uložte v priestore oddelene od vedenia motoru. Zabezpečte veľkú kontaktnú plochu medzi káblom a PE.

(bg) ВНИМАНИЕ

В сферата на действие на изискванията на ЕС устройствата с честотно управление и техните допълнителни устройства могат да бъдат приведени в употреба, само ако се установи, че оборудването съответства на изискванията за безопасност на машинно оборудване спрямо 2006/42/ЕО. Монтаж с електромагнитна съвместимост. Полагане на контролни и мрежови проводници пространствено отделно от проводниците на двигателя. Осигурете по-голяма контактна площ между силовия екран и PE.

(ro) ATENȚIE

În cadrul sferei de aplicare a directivelor UE dispozitivele controlate prin frecvență și accesoriile acestora au voie să fie puse în funcțiune doar dacă se stabilește că aparatul îndeplinește cerințele Directivei 2006/42/CE privind mașinile. Montajul trebuie să fie compatibil EMC. Poziționati cablurile de control și de rețea la distanță de cablul motorului. Asigurați o suprafață de contact mare între izolația cablului și PE.

(hr) PAZNJA

U području valjanosti Direktiva EZ frekvenjski upravljani uređaji i njihov pribor smiju se puštati u rad samo ako se utvrdi da stroj ispunjava zahtjeve za zaštitom iz Direktive o strojevima 2006/42/EZ.

Konstrukcija u skladu s EMC-om. Upravljački i mrežni vodovi prostorno položeni odvojeno od voda motora. zaslon kabla povezan PE-om na velikoj površini.

(tr) DİKKAT

AB Direktifi dahilinde, frekans kontrollü cihazlar ve aksesuarları, yalnızca makinenin 2006/42/EC Makina Emriyet Direktifi kuruma şartlarını karşıladığı belirlendiğinde çalıştırılmalıdır. EMC uyumlu kurulum sağlayın. Kontrol ve iletişim kablolarını uzamsal olarak motor kablolarından ayrı koyun. kablo ekranı ile PE arasında geniş bir temas alanı bağıntısı olmasını sağlayın.

(sr) ОПРЕЗ

На територији надлежности ЕУ директиве, фреквентно контролисани уређаји и њихова додатна опрема морају бити пуштени у рад само када је утврђено да машина испуњава захтеве за заштиту наведене у Директиви о машинама 2006/42/ЕЗ. Осигурајте инсталацију која је услагашена са ЕМС. Положите контролне и комуникационе каблове просторно одвојено од кабла мотора. Обезбедите везу велике површине контакта између екрана кабла и PE.

(no) FORSIKTIG

I EU-direktivets område må frekvensregulerte enheter og deres tilbehør kun settes i drift når det har blitt avgjort at maskinen oppfyller beskyttelseskravene i maskindirektiv 2006/42/EC. Sikre at installasjon har elektromagnetisk samsvar (EMC). Legg kontroll- og kommunikasjonskabler avstandsseparert fra motorkabelen. Sørg for et stort kontaktoverflate mellom -kabelskjerm og PE.

(uk) УВАГА

На території, на яку поширюється дія Директив ЄС, пристрої з частотним регулюванням та їхні приналежності можуть вводитися в експлуатацію лише в разі знання їх такими, що відповідають вимогам до захисту, викладеним у Директиві про машинне обладнання 2006/42/EC. Переконайтеся в тому, що встановлена система відповідає вимогам до EMC. Кабелі керування та зв'язку мають бути просторово відокремлені від кабелю електродвигуна. Зabezpečte достатню контактну поверхню між екраном кабелю та PE.

(ar) انتباه

في المنطقة التي تخضع لتوجيه الاتحاد الأوروبي، يجب ألا يتم تشغيل الأجهزة وملحقاتها التي يتم التحكم فيها بواسطة التردد إلا بعد التأكد من أنها تستوفي متطلبات حماية توجيه الماكينات 2006/42/EC.

ع كابلاتا للتوافق الكهرومغناطيسي. ضا حرص على أن يكون التركيب مطابقاً مع كابل المحرك. تأكد من وجود منطقة التحكم والاتصال بشكل منفصل مكاني PES و PE تلامس كبيرة بين شاشة كبل

Doc. No.: CE2400026

EU-Konformitätserklärung

EU declaration of conformity

Wir / We, Eaton Industries GmbH, 53105 Bonn, Germany,
Hein-Moeller-Str. 7-11, 53115 Bonn, Germany

erklären hiermit in alleiniger Verantwortung als Hersteller, dass das Produkt (die Produktfamilie)
declare under our sole responsibility as manufacturer that the product (family)

Frequenzumrichter DA1

Frequency Converter DA1

entsprechend der Auflistung auf Seite 2 den einschlägigen Bestimmungen der Richtlinie(n) des Rates entspricht:

according to the list on page 2 complies with the provisions of Council directive(s):

2014/30/EU	EMV-Richtlinie / EMC Directive
2011/65/EU + 2015/863	RoHS-Richtlinie / RoHS Directive
2006/42/EG	Maschinenrichtlinie / Machinery Directive
2009/125/EG	Ökodesignrichtlinie / Ecodesign Directive (Verordnung / Regulation 2019/1781)

und mit den folgenden Normen übereinstimmt:
based on compliance with the following standard(s):

EN 61800-5-2:2017	EN 61508-1:2010
EN 61800-5-2:2007	EN 61508-2:2010
EN IEC 62061:2021 ¹⁾	EN 61508-4:2010
EN IEC 63000:2018	EN 61508-5:2010
EN ISO 13849-1:2015 ²⁾	EN 61508-6:2010
EN ISO 13849-1:2023 ³⁾	EN 61508-7:2010
	EN 61800-5-1:2007 + A1:2017 + A11:2021 ⁴⁾

- 1) intended Application
2) intended Application
3) intended Application
4) 4.3, 5.2.6

Bonn, 12.04.2024



i.A. Edgar Willems
Manager Quality Business Line ICP
Power Management & Control Components Division

i.A. Lars Gundlach
Head of Product Line Management
Controls & Automation

Seite/page 1 / 2

Doc. No.: CE2400026

Typen des Sortiments

Types within the range

Die Konformitätserklärung gilt für folgende Typen der Produktfamilie und in Kombination mit den darunter folgenden Produkten:

The declaration of conformity applies to the following types within the product family and in combination with products listed below:

DA1...B..O

Die Übereinstimmung eines Baumusters des bezeichneten Produktes mit der Richtlinie
Consistency of a production sample with the marked product in accordance with the Directive

Maschinenrichtlinie 2006/42/EG / Machinery Directive 2006/42/EC

wurde bescheinigt durch
has been certified by

Notifizierte Stelle / Anschrift: NB 0035-TÜV Rheinland, Am Grauen Stein, 51105 Köln/Germany
Notified Agency / Address:

Nummer der Bescheinigung: 01/205/5962.00/24
Certification Number:

Ausstellungsdatum: 2024-02-26
Date of issue:

Das bezeichnete Produkt stimmt mit dem geprüften Baumuster überein.
The designated product is consistent with the examined type

Bevollmächtigter zur Zusammenstellung der technischen Unterlagen / Authorised Person to compile the technical file:
Eaton Industries GmbH, Hein-Moeller-Str. 7-11, 53115 Bonn, Germany

Bonn, 12.04.2024



i.A. Edgar Willems
Manager Quality Business Line ICP
Power Management & Control Components Division

i.A. Lars Gundlach
Head of Product Line Management
Controls & Automation

Seite/page 2 / 2

Additional Information for UL[®] Approved Installations

→ Refer to Manual MN040063EN

DA1 is designed to meet the UL requirements. In order to ensure full compliance, the following must be fully observed.

Input Power Supply Requirements

Supply Voltage	DA1-12...	200 - 240 RMS Volts for 230 Volt rated units, ±10 % variation allowed. 240 Volt RMS Maximum		
	DA1-32...	200 - 240 RMS Volts for 230 Volt rated units, ±10 % variation allowed. 240 Volt RMS Maximum		
	DA1-34...	380 - 480 Volts for 400 Volt rated units, ±10 % variation allowed, Maximum 500 Volts RMS		
	DA1-35...	500 - 600 Volts for 600 Volt rated units, ±10 % variation allowed, Maximum 600 Volts RMS		
Imbalance	Maximum 3 % voltage variation between phase – phase voltages allowed All DA1 units have phase imbalance monitoring. A phase imbalance of > 3 % will result in the drive tripping. For input supplies which have supply imbalance greater than 3 % Eaton Drives recommends the installation of input line reactors.			
Frequency	50 - 60 Hz ±5 % Variation			
Short Circuit Capacity	Voltage Rating	Min. kW (HP)	Max. kW (HP)	Maximum supply short-circuit current
	All	All	All	100 kA rms (AC)

All the drives in the above table are suitable for use on a circuit capable of delivering not more than the above specified maximum short-circuit Amperes symmetrical with the specified maximum supply voltage.

Incoming power supply connection

- For 3 phase supplies, power should be connected to L1, L2, and L3. Phase sequence is not important.
- For compliance with CE and C Tick EMC requirements, a symmetrical shielded cable is recommended.
- For compliance with CSA requirements, transient surge suppression shall be installed on the line side of this equipment and shall be rated 600 V (phase to ground), 600 V (phase to phase), suitable for overvoltage category III, and shall provide protection for a rated impulse withstand voltage peak of 4 kV or equivalent.
- A fixed installation is required according to IEC61800-5-1 with a suitable disconnecting device installed between the DA1 and the AC Power Source. The disconnecting device must conform to the local safety code/regulations (e. g. within Europe, EN60204-1, Safety of machinery).
- The cables should be dimensioned according to any local codes or regulations. Guideline dimensions are given on page 8/14.
- Suitable fuses to provide wiring protection of the input power cable should be installed in the incoming supply line, according to the data on page 8/14. The fuses must comply with any local codes or regulations in place. In general, type gG (IEC 60269) or UL type T fuses are suitable; however in some cases type aR fuses may be required. The operating time of the fuses must be below 0.5 seconds.
- Where allowed by local regulations, suitably dimensioned type B MCB circuit breakers of equivalent rating may be utilised in place of fuses, providing that the clearing capacity is sufficient for the installation.
- When the power supply is removed from the drive, a minimum of 30 seconds should be allowed before re-applying the power. A minimum of 5 minutes should be allowed before removing the terminal covers or connection.
- The maximum permissible short circuit current at the DA1 Power terminals as defined in IEC60439-1 is 100 kA.
- An optional Input Choke is recommended to be installed in the supply line for drives where any of the following conditions occur:
 - The incoming supply impedance is low or the fault level/short circuit current is high
 - The supply is prone to dips or brown outs
 - An imbalance exists on the supply (3 phase drives)
 - The power supply to the drive is via a busbar and brush gear system (typically overhead Cranes).
- In all other installations, an input choke is recommended to ensure protection of the drive against power supply faults.

All DA1 units are intended for indoor installation within controlled environments which meet the condition limits.

Ambient temperature range	Operational	-10 °C to 50 °C
	Storage and Transportation	-40 °C to 60 °C
Max. altitude for rated operation	1000 m (Refer to Manual for Derating for Altitude Information). Installation above 2000 m is not UL approved.	
Relative Humidity	< 95 % (non condensing). Drive must be Frost and moisture free at all times.	

Branch circuit protection must be installed according to the relevant national codes. Fuse ratings and types are shown on page 8/14.

Suitable Power and motor cables should be selected according to the data.
Power cable connections and tightening torques are shown on page 8/14.

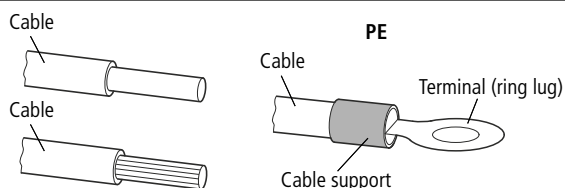

Motor Overload Protection

DA1 provides motor overload protection in accordance with the National Electrical Code (US).

- Where a motor thermistor is not fitted, or not utilised, Thermal Overload Memory Retention must be enabled by setting P4-12 = 1. Set the parameters P1-08 „Current Limit“ on motor current.
- Where a motor thermistor is fitted and connected to the drive, connection must be carried out according to the information shown on page 10/14.

-
- The maximum motor cable length stated applies to using a shielded motor cable. When using an unshielded cable, the maximum cable length limit may be increased by 50 %. When using the Eaton Drives recommended output choke, the maximum cable length may be increased by 100 %
 - The PWM output switching from any inverter when used with a long motor cable length can cause an increase in the voltage at the motor terminals, depending on the motor cable length and inductance. The rise time and peak voltage can affect the service life of the motor. Eaton Drives recommend using an output choke for motor cable lengths of 50 m or more to ensure good motor service life
 - For UL compliant installation, use Copper wire with a minimum insulation temperature rating of 70 °C, UL Class CC or Class J Fuses

12/24 IL040061ZU

