

Data Sheet | Item Number: 891-8982/116-601

pre-assembled connecting cable; Eca; Socket/open-ended; 2-pole; Cod. I;
H05Z1Z1-F 2 x 1,50 mm²; 6 m; 1,50 mm²; blue

<https://www.wago.com/891-8982/116-601>

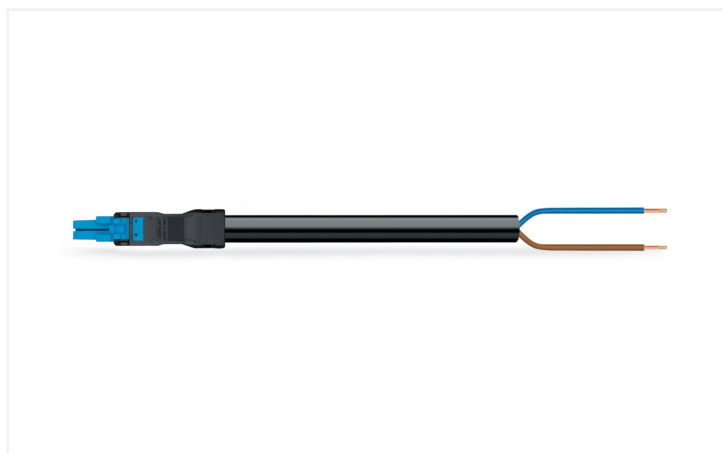

Color: ■ blue

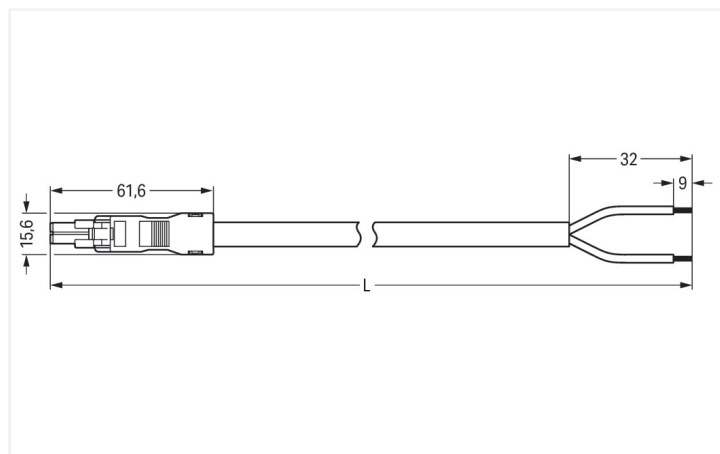

Dimensions in mm

Cable assembly *WINSTA*® MINI rated current 16 A

Use effective pluggable connections instead of laborious screw connections: With the *WINSTA*® MINI cable assembly 2-pole, WAGO pluggable installation connectors can be used when criteria repeat or are distributed on a specified pattern, for example for installing grid lighting or flush-mount lighting. For greater protection in electrical installations, the pluggable installation connector is equipped with mechanical protection against mismatching. The pluggable installation connector is protected against ingress by solid granular objects with a diameter of less than 1 mm in accordance with protection type IP40. I coding in blue is used to mark *WINSTA*® MINI pluggable installation connectors, which are used predominantly in building automation for activating lighting. Particularly where space is tight, our smallest pluggable connection system, *WINSTA*® MINI, consistently displays its advantageous properties. It is very compact, and, thanks to Push-in CAGE CLAMP® spring pressure connection technology, it also can be installed quickly, since the installation is low-maintenance and can be performed without screw connections. This product meets all the mandatory fire protection requirements of fire class E; as a result it can be used in domains where fire safety is relevant. In the manufacturing of this cable assembly, we eliminated the use of halogen. That is an important contribution to climate protection.

Fast, secure pluggable connections – cable assemblies from WAGO

A socket and a free end are provided. The *WINSTA*® Pluggable Connection System is ideally tailored to the very strict requirements of building installation. It makes electrical installation pluggable, and thus faster, more reliable, and error-free. Using this pre-assembled system reduces assembly times and installation errors at the construction site. Enjoy the benefits of the pluggable version of our maintenance-free spring pressure connection technology too! Plan your installation with with protection against mismatching from WAGO.

- pluggable installation connectors with protection against mismatching
- easy tool-free operation, a wide range of coding options
- with I coding for lighting control (DALI standard)
- flexible installation to save space
- quick replacement of defective units during ongoing operation

Notes

Note Cables with a different fire class can be found in the eShop.

Electrical data

Ratings per	IEC/EN 60664-1			General information	
Overvoltage category	III	III	II	Note on contact resistance	approx. 1 mΩ of contact resistance approx. 0.25 mΩ contact transition plug/ socket
Pollution degree	3	2	2		
Nominal voltage	250 V	-	-		
Rated impulse withstand voltage	4 kV	-	-		
Rated current	16 A	-	-		

Connection Data

Total number of potentials	2	Connection 1	
Conductor preparation	ultrasonically tip-bonded	Strip length	9 mm / 0.35 inches
		Pole number	2
		Wire cross-section	1.5 mm ²
		Strip length (outer insulation)	32 mm
		Connection type	Socket - free end

Physical data

Pin spacing	4.4 mm / 0.173 inches
Width	15.6 mm / 0.614 inches
Height	13.2 mm / 0.52 inches
Total length	6 m

Mechanical data

Use	DALI, Lighting Management
Coding	I
Variable coding	No
Marking	+ -
Potential marking	+ -
Mating force of a plug-in connection	approx. 20 ... 70 N (depending on pole number)
Retention force of a plug-in connection	when locked: > 80N
Unmating force of a plug-in connection	when unlocked: approx. 20 ... 70 N (depending on pole number)
Number of mating cycles	200, without resistive load
Connection type	Socket - free end
Type of pre-assembled cable	Connecting cable
Cable type	H05Z1Z1-F 2x1.5
Protection type	IP40

Plug-in connection

Mismating protection	Yes
Note on mismating protection	All WINSTA® components are 100% protected against mismating when: a.) plugging different numbers of poles b.) plugging while rotated 180 c.) plugging while laterally staggered d.) plugging one pole
Locking lever	Can be retrofitted
Locking of plug-in connection	Locking lever
Note on locking system	All connectors for mounted installations (snap-in versions for lighting fixtures or devices, all types of PCB and distribution connectors) are factory-equipped with locking levers to ensure plugs and sockets are securely locked. Additional locking levers are only required for flying leads (plug/socket).

Material data

Note (material data)	Information on material specifications can be found here
Color	blue
Insulation material (main housing)	Polyamide (PA66)
Fire class per EN 50575	E _{ca}
Contact material	Copper or copper alloy; surface-treated
Contact Plating	Tin
Fire load	179.639 MJ
Connector color	blue
Strain relief color	black
Sheathed cable color	black
Printing color of sheathed cable	white
Halogen-free	Yes
Silicon-free	Yes
Sheath material	Halogen-free
Rubber cable	No
Weight	474.3 g
Copper weight of the raw cable	0.029 kg/m

Environmental requirements

Processing temperature	-5 ... +40 °C
Continuous operating temperature	-35 ... +85 °C
Note on continuous operating temperature	Cable for temperatures ≤ 70 °C (including halogen-free) Insulating parts for temperatures ≤ 105 °C

Commercial data

PU (SPU)	1 pcs
Packaging type	unpacked
Country of origin	PL
GTIN	4055143391702
Customs tariff number	85444290900

Product Classification

UNSPSC	26121629
eCl@ss 10.0	27-44-06-04
eCl@ss 9.0	27-44-06-04
ETIM 9.0	EC002587
ETIM 10.0	EC002587
ECCN	NO US CLASSIFICATION

Environmental Product Compliance

RoHS Compliance Status	Compliant, No Exemption
------------------------	-------------------------

Downloads

Environmental Product Compliance

Compliance Search

Environmental Product Compliance 891-8982/116-601	↓
--	-------------------

Documentation

Bid Text

891-8982/116-601	19.02.2019	xml 3.08 KB	↓
891-8982/116-601	24.11.2014	doc 25.00 KB	↓

CAD/CAE-Data

CAE data

WSCAD Universe 891-8982/116-601	↓
------------------------------------	-------------------

1 Compatible Products

1.1 Required Accessories

1.1.1 Locking system

1.1.1.1 Locking system



<p>Item No.: 890-111 Locking lever; for flying leads; for tool operation; black</p>	<p>Item No.: 890-131 Locking lever; for flying leads; for tool operation; white</p>	<p>Item No.: 890-101 Locking lever; for manual operation; black</p>	<p>Item No.: 890-121 Locking lever; for manual operation; white</p>
---	---	---	---

1.2 Optional Accessories

1.2.1 Cover

1.2.1.1 Cover



Item No.: 897-2001

Protective cap; Type1; for sockets and plugs; PVC; red

1.2.2 Installation

1.2.2.1 Mounting accessories



Item No.: 890-310

Mounting carrier; 2- to 5-pole; for flying leads; black



Item No.: 890-311

Mounting carrier; 2- to 5-pole; for flying leads; white